

**KING COUNTY
ROAD DESIGN AND
CONSTRUCTION STANDARDS
2006**

TABLE OF CONTENTS

TABLE OF FIGURES	V
PURPOSE	VIII
CHAPTER 1. GENERAL CONSIDERATIONS.....	1-1
1.01 Shortened Designation	1-1
1.02 Applicability.....	1-1
1.03 Severability	1-1
1.04 Authority and Duties of Inspectors	1-1
1.05 Responsibility to Provide Roadway Improvements.....	1-2
1.06 General References.....	1-3
1.07 WSDOT/APWA Documents as Primary Design and Construction References	1-3
1.08 Other Specifications And Guidelines.....	1-1
1.09 Cultural Resources	1-1
1.10 Scenic Byways	1-2
1.11 Engineering Plans, Plans of Record, and Final Plat Plans	1-2
1.12 Variances.....	1-5
1.13 Errors and Omissions	1-6
1.14 Penalties and Financial Guarantees	1-7
1.15 Changes to this Manual.....	1-7
1.16 Definitions of Terms.....	1-7
CHAPTER 2. ROAD TYPES AND GEOMETRICS	2-1
2.01 Road Classifications	2-1
2.02 Rural Roadways.....	2-2
2.03 Urban Roadways	2-8
2.04 Horizontal Curvature and Sight Distance Design Values.....	2-13
2.05 Short Plats	2-14
2.06 Private Streets.....	2-15
2.07 Half Streets.....	2-16
2.08 Cul-de-sacs, Islands, and Hammerheads	2-17
2.09 Alleys and Private Access Tracts	2-18
2.10 Intersections and Low-Speed Curves.....	2-19
2.11 Maximum Grade and Grade Transitions.....	2-20
2.12 Stopping Sight Distance	2-20

2.13	Entering Sight Distance (ESD).....	2-22
2.14	Medians (Optional Design Feature).....	2-22
2.15	One-Way Streets.....	2-23
2.16	Bus Zones and Turn-Outs.....	2-23
2.17	Exception to Paving on Rural Minor Access Streets (Residential).....	2-23
2.18	Slope, Wall, and Drainage Easements and Right-of-Way Reduction.....	2-23
2.19	Access and Circulation Requirements.....	2-24
2.20	Exception for Maximum Dwelling Units on Urban Subcollectors.....	2-24

CHAPTER 3. DRIVEWAYS, SIDEWALKS, BIKEWAYS, TRAILS 3-1

3.01	Driveways.....	3-1
3.02	Concrete Sidewalks.....	3-3
3.03	Construction of Curbs, Gutters, and Sidewalks.....	3-4
3.04	Expansion and Dummy Joints.....	3-5
3.05	Curb Ramps.....	3-5
3.06	Concrete Steps, Metal Handrail and Barrier-Free Access Ramps.....	3-6
3.07	Asphalt Shoulders.....	3-6
3.08	Separated Pedestrian Walkways and Trails.....	3-6
3.09	School Access.....	3-7
3.10	Bikeways.....	3-7
3.11	Equestrian Facilities.....	3-8

CHAPTER 4. SURFACING 4-1

4.01	Residential Streets, Sidewalks, Walkways, and Bikeways.....	4-1
4.02	Driveway Surfacing.....	4-3
4.03	Street Widening.....	4-3
4.04	Requirements for Residential Streets on Poor Subgrade.....	4-4
4.05	Arterials and Commercial Access Streets.....	4-4
4.06	Materials and Lay-Down Procedures:.....	4-5
4.07	Asphalt Surfacing Repairs:.....	4-6
4.08	Pavement Markings, Markers, and Pavement Tapers.....	4-7

CHAPTER 5. ROADSIDE FEATURES..... 5-1

5.01	Rock Facings.....	5-1
5.02	Side Slopes.....	5-3
5.03	Street Trees and Landscaping.....	5-3

5.04	Mail Boxes	5-7
5.05	Street Illumination	5-9
5.06	Survey Monuments	5-9
5.07	Roadway Barricades	5-10
5.08	Bollards	5-10
5.09	Guardrail/Embankment Heights	5-11
5.10	Roadside Obstacles	5-11
CHAPTER 6. BRIDGES, SPECIAL CULVERTS, AND STRUCTURED WALLS.....		6-1
6.01	Bridge Principal References	6-1
6.02	Bridge Geometrics	6-1
6.03	Bridge Design Criteria.....	6-2
6.04	Special Culverts	6-3
6.05	Structural Walls	6-3
CHAPTER 7. DRAINAGE		7-1
7.01	General.....	7-1
7.02	Road Ditches.....	7-1
7.03	Storm Sewers and Culverts.....	7-2
7.04	Catch Basin Locations and Junctions	7-2
7.05	Frames, Grates, and Covers	7-3
7.06	Erosion Control	7-5
7.07	Trenches.....	7-5
CHAPTER 8. UTILITIES & INSTALLATION		8-1
8.01	Franchising Policy and Permit Procedure.....	8-1
8.02	Standard Utility Locations Within the Right-of-Way.....	8-1
8.03	Underground Installations.....	8-4
8.04	Notification and Inspection.....	8-7
8.05	Final Adjustment (To Finish Grade).....	8-7
8.06	Final Cleanup, Restoration of Surface Drainage and Erosion/Sediment Control	8-8
CHAPTER 9. CONSTRUCTION CONTROL AND INSPECTION		9-1
9.01	Basis for Control of the Work.....	9-1
9.02	Inspection	9-1
9.03	Penalties for Failure to Notify and Obtain Approval.....	9-3
9.04	Control of Materials	9-3

9.05	Embankment Construction Control in Developments	9-4
9.06	Subgrade	9-6
9.07	Traffic Control in Development Construction	9-6
9.08	County Forces and County Contract Road Inspection	9-7
9.09	Call Before You Dig	9-8
9.10	Utility Certification.....	9-8

TABLE OF FIGURES

SECTION 2-000 ROADWAY

Figure No.	Figure Title	Page
2-001	Rural Type Roadway	2-25
2-002	Vertical Curb Type Roadway	2-26
2-003	Rolled Curb Type Roadway	2-27
2-004	Gravel Surface Roadway	2-28
2-005	Extruded Curb Roadway	2-29
2-006	Culs-De-Sacs	2-30
2-007	Temporary Cul-de-Sac	2-31
2-008	Urban/Rural Eyebrow	2-32
2-009	Half Street	2-33
2-010	Alley Pavement Detail	2-34
2-011	Hammerhead Turnaround	2-35
2-012	Measuring Sight Distance	2-36
2-013	Intersection Landing	2-37

SECTION 3-000 CURBS, CURB RAMPS, SIDEWALKS, DRIVEWAYS, AND TRAILS

Figure No.	Figure Title	Page
3-001	Curb and Sidewalk Joints	3-10
3-002	Curb Details	3-11
3-003	Shoulder and Ditch Section Driveway	3-12
3-004	Location and Width of New Driveways	3-13
3-005	Joint Use Driveway Tract	3-14
3-006	Curb Ramp Locations	3-15
3-007	Curb Ramp	3-16
3-008	Curb Ramp/Planter Strip Within Radius	3-17
3-009	Cement Concrete Sidewalk Transition to Asphalt Shoulder	3-18
3-010	Curb Ramp Alternate	3-19
3-011	Typical Intersection Plan With Asymmetrical Lanes	3-20
3-012	Driveway Approach -Routed Sidewalk	3-21
3-013	Driveway Approach-Routed Sidewalk, Planting Strip	3-22
3-014	Driveway Approach, Parallel Sidewalk	3-23
3-015	Preferred Equestrian Trail Easement Adjacent to Public Street	3-24
3-016	Shared Use Trails, Paved Tread, Double Track	3-25
3-017	Shared Use Trails, Natural Tread, Double Track	3-26
3-018	Limited Use Trails, Paved Tread, Single Track	3-27
3-019	Bikeways	3-28

SECTION 4-000 CHANNELIZATION

Figure No.	Figure Title	Page
4-001	Pavement Markings	4-8
4-002	Intersection Approach Striping	4-9
4-003	Pavement Symbols	4-10
4-004	Raised Pavement Markers	4-11
4-005	Merge and Dual Turn Lane	4-12
4-006	Bike Lane and Right Turn Drop	4-13
4-007	Bike Lane and Right Turn Pocket	4-14
4-008	Left Turn Lane	4-15
4-009	Median Islands	4-16

SECTION 5-000 ROADSIDE APPURTENANCES

Figure No.	Figure Title	Page
5-001	Clearance of Roadside Obstacles on Shoulder Type Road	5-13
5-002	Barricades	5-14
5-003	Rock Facing, Cut Section	5-15
5-004	Rock Facing, Fill Section	5-16
5-005	Rock Facing Under Sidewalk	5-17
5-006	Rock Facing, Fill Section Reinforcement	5-18
5-007	Concrete Steps and Metal Handrail	5-19
5-008	Metal Handrail	5-20
5-009	Street Tree Location	5-21
5-010	Tree Setbacks/Blockouts/Rockerries	5-22
5-011	Tree Planting in Planting Strips	5-23
5-012	Larger Fills Around Trees	5-24
5-013	Minor Fills Around Trees	5-25
5-014	Mailbox Installation Type 1 & 2 (1 of 4)	5-26
5-015	Mailbox Installation Type 1 & 2 (2 of 4)	5-27
5-016	Mailbox Installation Type 1 & 2 (3 of 4)	5-28
5-017	(N.D.C.B.U.) Mailbox Installation Neighborhood Delivery and Collection Box Unit (4 of 4)	5-29
5-018	Bollards	5-30
5-019	Roadway Survey Monument With Case & Cover	5-31
5-020	Off-Roadway Survey Monument	5-32
5-021	Transverse Joint Planing	5-33

SECTION 7-000 DRAINAGE

Figure No.	Figure Title	Page
7-001	Beveled End Pipe Section	7-6
7-002	Field Tapping of Concrete Pipe	7-7
7-003	Catch Basin Type 1	7-8
7-004	Catch Basin Type 1-L	7-9
7-005	Catch Basin Type 2 - 48", 54", 60", 72" and 96"	7-10
7-006	Catch Basin Details	7-11
7-007	Manhole Type 1 - 48", 54" and 60"	7-12
7-008	Manhole Type 2 - 72" & 96"	7-13
7-009	Manhole Type 3 - 48", 54", 60", 72" and 96"	7-14
7-010	Manhole Type 4	7-15
7-011	Manhole Details	7-16
7-012	Curb Inlet	7-17
7-013	Standard Grate	7-18
7-014	Standard Frame with Vertical or Extruded Curb Installation	7-19
7-015	Solid Cover	7-20
7-016	Through-curb Inlet Frame	7-21
7-017	Through-curb Inlet Frame and Grate with Vertical Curb Installation	7-22
7-018	Vaned Grate	7-23
7-019	Rolled Curb Frame and Grate	7-24
7-020	Rolled Curb Frame and Grate Installation	7-25
7-021	Rolled Curb Vaned Grate	7-26
7-022	Locking Manhole Cover	7-27
7-023	Locking Manhole Frame	7-28
7-024	Rock-lined Shoulder Ditches-Curbed Shoulders	7-29
7-025	Restrictor Detail	7-30
7-026	Tee Section Shear Gate Detail	7-31
7-027	Flow Restrictor Control Device, Baffle Type	7-32
7-028	Debris Cage	7-33
7-029	Extended Debris Cage	7-34

KING COUNTY ROAD DESIGN AND CONSTRUCTION STANDARDS 2003

PURPOSE

King County has adopted these road design and construction standards primarily for a two-fold purpose:

1. To set forth specific, consistent and acceptable road design and construction elements for developers and other private parties constructing or modifying road or right-of-way facilities which require County licenses or permits;
2. To establish uniform criteria to guide the County's own design and construction of new County roads or reconstruction of existing roads.

In addition, these King County Road Design and Construction Standards, hereafter known as the Standards, are intended to support King County's goals for achieving affordable housing, providing adequate facilities for development in an efficient manner, complying with storm water management and environmental and cultural resource policies, and to balance these goals with the general safety and mobility needs of the traveling public.

The County requires standardization of road design elements where necessary for consistency and to assure so far as practical that motoring, bicycling, transit, equestrian, and pedestrian public safety needs are met. Considerations include safety, convenience, pleasant appearance, proper drainage, economical maintenance, and cultural and environmental resource protection. The Standards also provide requirements for the location and installation of utilities within the right-of-way.

The County's permitting and licensing activities require the adoption of specific identifiable standards to guide private individuals and entities in the administrative process of procuring the necessary County approval. Yet, the County must have flexibility to carry out its general duty to provide streets, roads, and highways for the diverse and changing needs of the traveling public. These Standards are not intended to represent the legal standard by which the County's duty to the traveling public is to be measured.

These Standards cannot provide for all situations. They are intended to assist but not to substitute for competent work by design professionals. It is expected that land surveyors, engineers, architects, and contractors will bring to each project the best of skills from their respective area of expertise. These Standards are not intended to limit unreasonably any economically maintained innovative or creative efforts or lower impact development alternatives that could result in equivalent or improved safety, quality, and maintainability. Environmental constraints may require more intense or rigorous design parameters than would be otherwise required. However, any proposed departure from the Standards will be judged on the likelihood that such variance will produce a compensating or comparable result, in every way safe and adequate for the public.

CHAPTER 1. GENERAL CONSIDERATIONS

1.01 Shortened Designation

These King County Road Design and Construction Standards will be cited routinely in the text as the "Standards."

1.02 Applicability

These Standards shall apply prospectively to all newly constructed road and right-of-way facilities, both public and private, within King County. In the event of conflict with the surface water design manual, improvements within the roadway right-of-way shall meet the requirements of these Standards.

The Standards apply to modifications of roadway features or existing facilities which are within the scope of reconstruction, widening, required off-site road improvements for land developments, or capital improvement projects when so required by King County or to the extent they are expressly referred to in project plans and specifications. These Standards are not intended to apply to "resurfacing, restoration, and rehabilitation" projects, also known as 3R projects, as those terms are defined in the Washington State Department of Transportation (WSDOT) Local Agency Guidelines Manual (LAG), as amended; however, the County Road Engineer may at his/her discretion consider the Standards as optional goals for the design and construction of 3R projects.

The Standards shall apply to every new placement and every planned, non-emergency replacement of existing utility poles and other utility structures within the King County right-of-way. Every effort shall be made to meet the Standards during emergency replacement of existing utility poles and other structures.

1.03 Severability

If any part of these Standards as adopted by ordinance shall be found invalid, all other parts shall remain in effect.

1.04 Authority and Duties of Inspectors

The County Road Engineer may designate inspectors to inspect all materials used and all work performed. Such inspection may extend to any or all parts of the work and to the preparation and/or manufacture of the materials to be used. The inspector will not be authorized to revise, alter, or relax the provisions of these Standards.

All roadway and drainage infrastructures must be inspected. Subgrade inspection will not commence until density tests confirm that the compaction is in accordance with the specifications. The inspector has the authority to reject defective material and suspend work that is being done improperly. The inspector may advise the applicant or contractor of any faulty work or materials; however, failure of the inspector to advise the applicant or contractor does not constitute acceptance or approval. The

inspector has the authority to require revisions to approved engineering plans when necessary due to conflicting field conditions.

1.05 Responsibility to Provide Roadway Improvements

- A. Any land development, which will impact the service level, safety, or operational efficiency of roads serving such land development or is required by other County code or ordinance to improve such roads, shall improve those roads in accordance with these Standards. Off-site roadway improvements shall be based on an assessment of the impacts of the proposed land development by the Reviewing Agency.
- B. Any land development abutting and impacting existing roads shall improve the frontage of those roads in accordance with these Standards. The extent of improvements shall be based on an assessment of the impacts of the proposed land development by the Reviewing Agency.
- C. Any land development that contains internal roads shall construct or improve those roadways in accordance with these Standards, unless otherwise specified in King County Code Title 21A.
- D. For commercial developments, these Standards shall apply unless otherwise determined by the Development Engineer and/or as specified by King County Code Title 21A. These Standards shall apply to commercial developments with public/dedicated rights-of-way or easements, unless otherwise determined by the Development Engineer.
- E. For a commercial establishment on a shoulder and ditch type road, where development of adjoining lands and highway traffic assume urban characteristics as determined by the Development Engineer, the frontage shall be finished with curb, gutter, and sidewalk, with pipe drainage, all in accordance with these Standards. Alternatively, the Development Engineer may require the entire frontage area to be graded and paved to the right-of-way line with asphalt. In such cases, surface drainage shall be intercepted and carried in a closed system as set forth in Chapter 7. Access shall be limited by means of concrete curbing.
- F. Subdivisions, short subdivisions, binding site plans or any other developments that are subject to recording shall not be recorded until there exists a recorded continuous public maintained access, or an access that is covered by a maintenance financial guarantee to the development site, except as provided for in Section 2.06. Additionally, the County will not accept a road or the drainage improvements within the road rights-of-way for maintenance until the road is directly connected to a County maintained or an acceptable publicly maintained road. This requirement also applies to public roadways located within a commercial development and those public roadways created through the binding site plan process and any other permit process.
- G. All new and reconstructed road and development projects shall provide applicable pedestrian, bicycle, and equestrian improvements that meet the Standards, unless otherwise approved by the County Road Engineer.

1.06 General References

The Standards are intended to be consistent with:

- A. Home Rule Charter for King County, approved by the electorate on November 5, 1968; specifically subsection 920.20.10.
- B. King County Code, as amended, including:
 - Title 9, Surface Water Management
 - Title 14, Roads and Bridges
 - Title 16, Building and Construction Standards
 - Title 17, Fire Code
 - Title 19A, Subdivisions
 - Title 20, Planning
 - Title 21A, Zoning
 - Title 27A, Financial Guarantees
 - Titles 46 and 47, Traffic
- C. Implementing guidelines prepared by King County Department of Natural Resources, and hereafter referred to as the "Surface Water Design Manual."
- D. King County Comprehensive Plan 2004, current edition.
- E. Affordable Housing Policy Plan, current edition.
- F. King County Regional Trails Plan, current edition.
- G. King County Non-Motorized Transportation Plan, current edition.
- H. King County Capital Improvement Program, current edition.
- I. King County Parks and Open Space Plan, current edition.
- J. King County adopted Basin Plans, current edition.
- K. King County Flood Hazard Plan, current edition.
- L. Americans with Disabilities Act (ADA).

1.07 WSDOT/APWA Documents as Primary Design and Construction References

Except where these Standards provide otherwise, the design detail, construction workmanship, and materials shall be in accordance with the following publications:

- A. WSDOT/APWA Standard Specifications for Road, Bridge, and Municipal Construction, as adopted by King County, current edition as amended. These will be referred to as the "WSDOT/APWA Standard Specifications."
- B. The WSDOT/APWA Standard Plans for Road and Bridge Construction, to be referred to as the "WSDOT/APWA Standard Plans," current edition as amended.
- C. WSDOT Design Manual, current edition as amended.

-
- D. City and County Design Standards for the Construction of Urban and Rural Arterial and Collector Roads, adopted in accordance with RCW 35.78.039 and RCW 43.32.020, current edition.

1.08 Other Specifications And Guidelines

The following specifications and guidelines shall be applicable when pertinent, when specifically cited in the Standards, when required as a development condition, or when required by state or federal funding authority.

- A. Local Agency Guidelines, WSDOT, current edition.
- B. Guidelines for Urban Arterial Program, WSDOT, current edition.
- C. Design criteria of federal agencies including the Federal Housing Administration, Department of Housing and Urban Development and the Federal Highway Administration, Department of Transportation.
- D. A Policy on Geometric Design of Highways and Streets, American Association of State Highway and Transportation Officials (AASHTO), current edition, as amended and approved by the WSDOT.
- E. Standard Specifications for Highway Bridges, adopted by AASHTO, current edition.
- F. Department of Transportation Manual on Uniform Traffic Control Devices, (MUTCD), current editions, as amended and approved by WSDOT.
- G. Guide for the Development of Bicycle Facilities, adopted by AASHTO, current edition.
- H. American Society for Testing and Materials (ASTM).
- I. Metro Transportation Facility Design Guidelines, current edition.
- J. Roundabouts: An Informational Guide, FHWA, current edition.
- K. AASHTO Standard Specifications for Structural Supports for Highway Signs, Luminaries and Traffic Signals, current edition.
- L. Section 106 of the National Historic Preservation Act (49U.S.C. 470) and 36, CFR 800, as amended.
- M. Section 4(f) of the Department of Transportation, as amended.
- N. Washington State High Occupancy Vehicle (HOV) Policy
- O. FHWA Guidance on HOV Lanes

1.09 Cultural Resources

All impacts to any significant cultural resources shall be avoided where and whenever possible, King County Code 20.62. To maximize the opportunities to plan for avoidance, significant cultural resources within or adjacent to a road or development project shall be identified as early in the planning process as possible. At a minimum the following shall apply:

- A. The applicant shall commence early consultation with the King County Historic Preservation Program office and the affected federally recognized tribe(s) as soon as possible in an effort to identify significant cultural resources in the planning stages.
- B. For certain categories of cultural resources, including Historic Landscapes and Districts, and Heritage Corridors and Scenic Byways, the installation or replacement of barrier systems, lighting, and signage shall be done in consultation with the Historic Preservation Program office, who may condition materials or placement.
- C. No project shall be permitted in or adjacent to designated King County Landmarks, until and unless the King County Historic Preservation Program office has issued a Certificate of Appropriateness.
- D. For projects in and adjacent to archaeological sites, consultation with the Washington State Department of Archaeology and Historic Preservation is also required (RCW 27.53).

1.10 Scenic Byways

RCW 47.39.075 states that local, regional, or other governmental bodies shall develop a corridor management plan for nominated routes that are under their jurisdiction. King County will develop a local Scenic Byways and Heritage Corridor program and work with other jurisdictions to address these requirements.

State of Washington designated Scenic Byways located in King County include but are not limited to:

1. The Cascade Loop (which includes portions of SR-2)
2. The Mountains to Sound Greenway (I-90)
3. The Stevens Pass Greenway (SR-2)
4. The Cascade Valleys Heritage Corridor (SR-202)
5. The Mather Memorial Parkway/Chinook Scenic Byway (SR-410)

In addition to these state designated byways, King County may designate local scenic byways and heritage corridors.

1.11 Engineering Plans, Plans of Record, and Final Plat Plans

- A. Engineering Plans: Engineering plans for private development proposals shall be prepared and submitted to the Reviewing Agency that meets at a minimum the following:
 1. A professional engineer licensed in the state of Washington shall prepare the engineering plans. The plans must be reviewed and approved by the Reviewing Agency prior to beginning construction.
 2. The plans must be signed and stamped by the responsible professional engineer prior to submittal to the Reviewing Agency.
 3. The plans shall be 24"x 36" or 22"x 34" sheet size, dark line on light background. The sheets shall be good quality reproducible ink on mylar or equivalent. Engineer scale shall be required.

4. At a minimum, the plans title block shall include the project name and number, applicant's/developer's name, and the name, address, seal, date and signature of the responsible professional engineer.
5. All topographic features within and adjacent to proposed improvements and within sufficient area to assess impacts of slopes, drainage, access, future extensions, etc. shall be incorporated into the plans.
6. All existing and proposed public and private utilities, including water and sewer, telephone, power, gas, cable, and any other utilities within the project area shall be shown on the plans.
7. Delineate existing and proposed drainage facilities such as culverts, catch basins, ditches, etc., indicate direction of flow, size, type of pipe, invert and rim elevations.
8. Identification of adjacent roads, neighborhoods, addresses or any other information to facilitate locations and future reference.
9. Profile drawings shall have a horizontal scale of not more than 50 feet to the inch or a vertical scale of not more than 10 feet to the inch. Plan views shall be of a corresponding horizontal scale.
10. The vertical and horizontal survey controls shall meet the requirements of KCC 19A.08.130.
11. The plans shall clearly identify all existing and proposed improvements, such as the right-of-way and/or easement lines, the roadway, sidewalks, shoulders, utilities, drainage facilities, rockeries, retaining walls and driveways. Existing and proposed driveway cross sections are required.
12. Curb return elevations at a minimum shall be shown at quarter points at all intersections to verify drainage and to facilitate a smooth transition.
13. Roadway profiles shall include existing and proposed centerline elevations at least 50 foot stations; centerline grades and vertical curves, including stations and elevations at PVC's, PVI's, and PVT's. When existing or proposed roadway includes superelevation, a superelevation diagram shall be included.
14. Detail drawing shall contain adequate dimensions, sections, views, notes, and call outs to construct the structure, or permit preparation of detailed shop drawings by the fabricator when necessary. Use of very light gray shading and very light hatching is acceptable, provided they do not obscure data and other pertinent information at full and reduced scale.
15. Channelization plans for intersections shall be provided at a 1"= 20' scale.
16. Channelization plans for connecting roadways may be 1"= 40' scale.
17. The plans must include existing and proposed monuments. The roadway centerline, easements, and other pertinent data will be referenced to existing monuments.

18. When applicable, the plans shall incorporate the engineering plan requirements of the County's Surface Water Design Manual.
 19. The County Road Engineer or Development Engineer may require additional plan elements in addition to those cited above.
- B. Waiver of Plan Requirements: Subject to review, the Development Engineer may waive plan requirements, wholly or in part, based on the following criteria:
1. No more than 2,000 square feet will be cleared and graded within the right-of-way or easement; and
 2. The existing grade or slope in the road right-of-way or easement does not exceed 8 percent; and
 3. The work will not intercept a stream, wetland, or sensitive area buffer, or otherwise impact sensitive areas and natural surface drainage as set forth in King County Code Title 21A and the Surface Water Design Manual; and
 4. Plans do not include a retention/detention facility; and
 5. The work is required of a short plat development, or a right-of-way use permit and involves less than 100 lineal feet of existing public road improvement; and
 6. King County standard drawings, submitted with required permits, are sufficient to describe the improvement to be constructed.
- C. Record Plans: Plan sheets are subject to a physical test that includes wet/dry erasers.
1. Final corrected plans for archiving shall be original documents that meet the minimum requirements listed in this section that are produced in a manner that ensures durability, resistance to damage from use or exposure to water or light, and that any alteration is detectable. Record drawings shall be of suitable quality for producing legible prints through reductions, scanning, microfilming or other standard copying procedure.
 2. Acceptable processes to create record drawings include black ink on 4 mil polyester drafting film (mylar), photographic mylar, mylar created using an ink jet printer process, or other processes approved by the Engineer. The following criteria shall be used to evaluate acceptability:
 - a. Substrates (such as polyester, polyethylene or polypropylene) shall be durable and capable of producing copies without loss, distortion or transfer of print or images. Ink shall be pigmented and ultraviolet (UV) resistant.
 - b. Drawing materials shall ensure a stable, reproducible document for a minimum of 50 years to comply with record retention requirements.
 3. Unacceptable processes to create record drawings include, but are not limited to:

- a. Mylars that have material affixed by adhesive.
 - b. Mylars that have shading, except for detail drawings as allowed in this section and when very light shading is used to delineate edge of existing pavement/surface.
 - c. Electrostatic mylars such as a xerographic process or mylars created by heat sensitive electrostatic plotting, except as approved by the Engineer.
 - d. Ammonia process (sepia type) mylars.
- D. Final Plat Plans/Maps: An electronic copy of the final plat map(s) shall be submitted to the reviewing agency when the plans/maps are forwarded to the County Assessor's office.
- E. Plans shall comply with Section 1.10(C) prior to receiving final construction approval.
- F. Engineering plans shall be reviewed to ensure that all road elements proposed for public maintenance will be maintained by the County. Maintenance plans may be required for specialized features. For purposes of public maintenance, a maximum reach of 16 feet by a backhoe type bucket shall be assumed.

1.12 Variances

- A. A road variance is required for any design or construction deviation from these Standards. Detailed procedures for applicants requesting variances and appealing variance decisions are contained within an administrative public rule that is available from the County Road Engineer or the Reviewing Agency.
- B. Variances from these Standards may be granted by the County Road Engineer upon evidence that such variances are in the public interest and that requirements for safety, function, fire protection, transit needs, appearance and maintainability based upon sound engineering and technical judgment are fully met.
- C. Variance requests for subdivisions should be proposed at preliminary plat stage and prior to any public hearing. All known variances must be approved prior to approval of the engineering plans for construction. It is the responsibility of the County Road Engineer to interpret the Standards. Any anticipated variances from these Standards, which do not meet the Uniform Fire Code will require concurrence by the King County Fire Protection Engineer.
- D. Applications for Road Variances:
 1. Applications for proposed variances shall be written and include a specific description of the proposed alternative along with documentation. Documentation may include, but not be limited to, a record of successful use by other agencies, or evidence of meeting criteria for quality such as AASHTO and ASTM standards.
 2. The applicant shall indicate those sections of the Standards, which are relevant to the proposed alternative.

3. Applications for location of utilities by an entity allowed under a franchise agreement must be prepared and submitted by that entity.
 4. Variance requests not associated with a development proposal subject to review by the DDES, shall be directed to the County Road Engineer, King County Department of Transportation, 201 South Jackson Street, MS KSC-TR-0231, Seattle, WA 98104-3856.
 5. Variance requests associated with a development proposal subject to review by DDES shall be directed to DDES, ATTN: Development Engineer, on forms prescribed by the County Road Engineer and DDES, and shall be accompanied by the variance review fee as specified in Title 27.
 6. Variance application forms and submittal requirements are available on the King County Internet side at www.metrokc.gov/ddes or at 900 Oakesdale Ave. SW, MS OAK DE 0100, Renton, Washington 98055.
- E. Questions regarding interpretation of these Standards may be directed to the Department of Transportation, Road Services Division at 206-296-6530.
- F. The County Road Engineer has granted the Development Engineer the decision-making authority for road variances in the following specified areas that relates to development permits. This authorization is reviewed and approved annually through a memorandum of agreement.
1. Offsite Road Improvement Requirements (Section 1.04A)
 2. Engineering Plan Requirements (Section 1.10)
 3. Determine Urban or Rural Roadway Section (Section 2.01)
 4. Private Access Tracts and Private Streets – Not to exceed 20 lots (Section 2.06)
 5. Alley Design (Section 2.09A)
 6. Street Grade Transitions (Section 2.11)
 7. Stopping Sight Distance for Sag Residential Curves (Section 2.12)
 8. Off-Street Walkway – Location (Section 3.02)
 9. Paved Shoulders (Section 3.07)
 10. Mailbox Location (Section 5.04)
 11. Bollard Design (Section 5.08)

Note: Under these circumstances, road variance decisions by the County Road Engineer are required only when the applicant disagrees with the Development Engineer's decision.

1.13 Errors and Omissions

At the discretion of the County Road Engineer or Development Engineer, any significant errors or omissions in the approved plans or information used as a basis for such approvals may constitute grounds for withdrawal of the approvals and/or stoppage of any or all permitted work. It shall be the responsibility of the applicant,

developer, or contractor to show cause why such work should continue, and make such changes in plans that may be required by the County Road Engineer or Development Engineer before the plans are re-approved.

1.14 Penalties and Financial Guarantees

Failure to comply with these Standards will be cause for denial of plan or development permit approval, revocation of prior approvals, withholding and reductions of financial guarantees, withholding final inspection approval, withholding occupancy certificates (temporary and permanent), legal action for forfeiture of financial guarantee, code enforcement, and/or other penalties as provided by law.

A. PERFORMANCE/RESTORATION FINANCIAL GUARANTEES: Any construction work on King County right-of-way (both maintained and unmaintained) other than Capital Improvement Projects by the County, County maintenance work, or as waived by K.C.C. 27A and King County ordinance 12020 shall be guaranteed by a restoration financial guarantee or Public Agency Service Agreement (PASA). All work on private road and drainage facilities, required as a condition of a County approval process, shall be guaranteed by a performance financial guarantee at the time of plat recording. The Development Engineer shall determine the amount and form of the financial guarantee. The minimum restoration and/or performance guarantee shall be \$2,000.00.

B. MAINTENANCE/DEFECT GUARANTEES: The successful performance of the right-of-way improvements or related drainage facilities shall be guaranteed for a period of at least two years (or other period if updated by King County Code) from the date of the Construction Approval. The Development Engineer shall determine the amount and form of the maintenance financial guarantee. The minimum maintenance guarantee shall be \$2,000.00. Maintenance guarantees will not be required when the required performance guarantee is \$2,000.00.

1.15 Changes to this Manual

The County Road Engineer may incorporate minor changes to these Standards as they become necessary. General updates shall include an opportunity for public review and comments.

1.16 Definitions of Terms

When referring to these Standards the definitions below shall apply.

AASHTO	American Association of State Highway and Transportation Officials
ADA	Americans with Disabilities Act
ADT	The Average Daily Traffic (ADT) is the general unit of measure for traffic defined as the total volume during a given time period (in whole days), greater than one day and less than one year, divided by the number of days in that time period.

Alley	A privately maintained thoroughfare, tract, or easement, usually narrower than a street, which provides access to the rear boundary of one or more lots and is, not intended for general traffic circulation.
Applicant	Applicant means a property owner or a public agency or public or private utility which owns a right-of-way or other easement, has been granted possession and use of a right-of-way or other easement in a written agreement signed by the property owner or has obtained a court order in a condemnation proceeding adjudicating that the use for which the agency or utility seeks to condemn the right-of-way or easement is a public use, or any person or entity designated or named in writing by the property or easement owner to be the applicant, in an application for a development proposal, permit or approval, or their successors or assigns.
Appurtenance	Equipment and/or accessories that are part of an operating system or subsystem.
APWA	American Public Works Association
As-Built Drawings	See Final Corrected Plans
ASTM	American Society for Testing and materials
ATB	Asphalt treated base
Auxiliary Lane	The portion of the roadway adjoining the traveled way for parking, turning or other purposes supplementary to through-traffic movement.
Backfill	Replacement of excavated material with suitable material compacted as specified.
Bikeway	A generic term for any road, street, path, or way which in some manner is specifically designated for bicycle travel, regardless of whether such facilities are designated for the exclusive use of bicycles or are to be shared with other transportation modes.
Breakaway Structure	A structure that has been crash tested in accordance with National Cooperative Highway Research Program procedures – NCHRP 230.
Boring	Grade and alignment controlled mechanical method of installing a pipe or casing under a road or stream without disturbing the surrounding medium.
Bulb	A round area for vehicle turnaround typically located at the end of a cul-de-sac street.
Bus Zone	A designated space for loading and unloading transit passengers.

Channelization	The separation or regulation of conflicting traffic movements into definite paths of travel by the use of pavement markings, raised islands or other suitable means to facilitate the safe and orderly movement of both vehicles and pedestrians.
Clear Run-Out Area	The area beyond the toe of a nonrecoverable slope available for safe use by an errant vehicle.
Clear Zone	The total roadside border area starting at the edge of the traveled way available for use by errant vehicles. This area may consist of a shoulder, a recoverable slope, a nonrecoverable slope, and/or a clear run-out area.
CMP	Corrugated metal pipe
Compaction	The densification of a fill by mechanical means.
County Road Engineer	King County Road Engineer, having authorities specified in RCW 36.75.050 and 36.80, or his/her authorized representative.
Critical Areas	Those areas which are subject to natural hazards or those land features which support unique, fragile, or valuable natural resources including fish, wildlife and other organisms and their habitat and such resources which carry, hold or purify water in their natural state. Sensitive areas include but are not limited to coal mine hazard areas, erosion hazard areas, flood hazard areas, landslide hazard areas, seismic hazard areas, steep slope hazard areas, streams, volcanic hazard areas, wetlands and sensitive area buffers.
CSBC	Crushed surfacing base course
CSTC	Crushed surfacing top course
Cul-de-sac	A short street having one end open to traffic and the other temporarily or permanently terminated by a vehicle turnaround at or near the terminus.
Cultural Resources	Material evidence of human activities, occupations, and systems illustrated by districts, sites, landscapes, structures, objects, artifacts, ruins, buildings, and natural features that have been or are important in human history and prehistory, and in the maintenance of living cultures.
Dead End	A road/street without an exit.
Design Speed	The speed approved by the County Road Engineer for the design of the physical features of a road as established by Sections 2.02 and 2.03, for residential and commercial access streets or equal to 10 miles per hour above the posted speed limit for arterials.

Developer	See Applicant
Development Engineer	The Department of Development and Environmental Services (DDES) employee responsible for the conditioning, review, inspection, and approval of right-of-way use permits, and road and drainage improvements constructed as part of development permits administered by DDES. The development engineer or his/her authorized representative shall be a professional civil engineer registered and licensed under the laws of the State of Washington.
Driveway	A privately maintained access to residential, commercial or industrial properties.
Dwelling Unit	One or more rooms designed for occupancy by a person or family for living and sleeping purposes, containing kitchen facilities and rooms with internal accessibility, for use solely by the dwelling's occupants; dwelling units include but are not limited to single detached units, townhouses, condominiums, apartments, factory built housing, mobile homes, and accessory units.
Eyebrow	A partial bulb located adjacent to the serving road that provides access to lots and serves as a vehicle turnaround.
Final Corrected Plans	The plan set which is certified to contain a true and accurate representation of the actual field conditions for the project during construction, or upon completion of construction. Also known as "As-Built Drawings".
Geometrics	The physical arrangement of the visible elements of a road such as alignment, grade, curvature, width and side slopes.
Grade	Rate or percent of change in slope measured along the centerline of the roadway or access point either ascending or descending from or along the roadway/access point.
Half-Street	A road section built adjacent to the property line that serves a maximum of 35 dwelling units or equivalent ADT, which eventually will be completed to a full width road section when the adjacent property is developed.
Hammerhead	An alternative turnaround at the terminus of a road running lateral to the road at the end. Serves not more than 4 dwelling units.

Heritage Corridor	A transportation corridor that is known for its intrinsic historic resource values irrespective of jurisdictional boundaries and ownership.
HMA	Hot mix asphalt
In-fill Development	The development of a parcel of land in a highly developed urban area.
Intersection	The area from the intersection of a roadway to the radius tangent point or stop bar on each approach, whichever is greater.
Joint-Use Driveway	A jointly owned and maintained driveway serving two properties.
KCC	King County Code
Landing	A road or driveway approach area to any public or private road. Also, the level area at the back of the sidewalk ramp, typically four-foot wide.
Loop	Road of limited length forming a loop, having no other intersecting road, and functioning mainly as direct access to abutting properties. A loop may be designated for one-way or two-way traffic. The desired maximum length of a loop is 600-feet.
Lot	A physically separate and distinct parcel of property that has been created pursuant to the provisions of Title 19A or pursuant to any previous laws governing the subdivision, short subdivision or segregation of land.
Low Impact Development	An innovative ecosystem based approach to land development and storm water management that results in fewer environmental impacts.
Low Volume Road	A rural collector arterial with an ADT of 400 or less.
MPH	Miles per hour
MUTCD	The Manual on Uniform Traffic Control Devices, published by the U.S. Department of Transportation.
New Construction	New construction involves the construction of a new roadway facility or structure where nothing of its type currently exists.
Off-Street Parking Space	An area accessible to vehicles, exclusive of roadways, sidewalks, and other pedestrian facilities that is improved, maintained, and used for the purpose of parking a motor vehicle.
Pavement Widening	Pavement widening projects are expansion of the roadway surface for vehicular use and may involve earthwork, drainage and paving elements. These

	projects are considered alterations of the roadway and must address ADA accessibility for pedestrians.
Pavement Width	Paved area on shoulder-type roads or paved surface between curb or gutter flow line on all other roads as depicted on Drawings 2-001 through 2-003, and 2-005.
Permittee	See Applicant
PI	Point of intersection
Pipe Stem	A strip of land having a width narrower than that of the lot or parcel to be served and designed for providing access to that lot or parcel.
Plan of Record	See Final Corrected Plans
Posted Speed	The speed limit actually signed along the roadway.
Private Access Tract	A privately owned and maintained tract that is 150 feet or less in length that provide vehicular access to six or fewer residential properties.
Private Street/Road	A privately owned and maintained access provided for by a tract, easement or other legal means, typically serving three or more potential dwelling units.
Professional Engineer	A professional civil engineer registered and licensed to practice in the State of Washington.
PS&E	Plans, Specifications and Estimate
PT	Point of tangent
Public Street	Publicly owned facility-providing access, including the roadway and all other improvements, inside the right-of-way.
RCW	Revised Code of Washington
Reconstruction	Reconstruction projects add additional lanes to an existing roadway or bridge and 50 percent or more of the project length involves vertical or horizontal alignment changes.
Recoverable Slope	A slope on which the driver of an errant vehicle can regain control of the vehicle. Slopes of 4H: 1V or flatter are considered recoverable.
Rehabilitation	Work similar to restoration except the work may include reworking or strengthening the base or subbase, recycling or reworking existing materials to improve their structural integrity, adding underdrains, replacing or restoring malfunctioning joints, substantial pavement under-sealing when essential for stabilization, pavement grinding to restore smoothness-providing adequate structural thickness remains, removing and replacing

	deteriorated materials; crack and joint sealing but only when the required shape factor is established by routing or sawing, improving or widening shoulders.
Restoration	Work performed on pavement or bridge decks to render them suitable for resurfacing. This may include supplementing the existing roadway by increasing surfacing and paving courses to provide structural capability, and widening up to a total of ten feet. Restoration will generally be performed within the exiting right-of-way.
Resurfacing	The addition of a layer or layers of paving material to provide additional structural integrity, improve serviceability, and rideability.
Reviewing Agency	King County Department of Development and Environmental Services or its successor agency responsible for reviewing subdivisions and other developments within their jurisdiction.
Right-of-Way	Public land, property, or property interest, (e.g., an easement), usually in a strip, as well as bridges, trestles, or other structures, acquired for or devoted to transportation purposes. This does not include recreational or nature trails except where they intersect with or are located within road rights-of-way.
Road	A facility serving three lots or more and providing public or private access including the roadway and all other improvements inside the right-of-way. NOTE: "Road" and "Street" will be considered interchangeable terms for the purpose of this document.
Roadway	Pavement width plus any paved or non-paved shoulders.
Resource Lands	Areas designated in the King County Comprehensive Plan that are characterized by long-term agriculture, forestry, and mining.
Rural Areas	Areas designated in the King County Comprehensive Plan that are located outside an urban growth area that are generally characterized by long-term low density residential and commercial/industrial development.
Scenic Byway	A transportation corridor having special scenic, historic, recreational, cultural, archaeological, and/or natural qualities.
Significant Cultural	

Resource	A cultural resource that is 40 years or older, and is listed on or eligible for listing on the King County Landmarks Register, Washington State Heritage Register, or National Register of Historic Places.
Shared Roadway	A roadway that is open to both bicycle and motor vehicle travel. This may be an existing roadway, a street with wide curb lanes, or a road with paved shoulders.
Shoulder	The paved or unpaved portion of the roadway outside the traveled way that is available for emergency parking or non-motorized use.
Street Frontage	Any portion of a lot or combination of lots that directly abuts a public right-of-way.
Surety	A bonding company, for example.
Surveyor	A professional land surveyor registered and licensed by the State of Washington.
Temporary	Lasting for a “limited” time.
Traffic Engineer	King County Traffic Engineer responsible for design, operation and maintenance of traffic control devices.
Traveled Way	The portion of a street or road intended for the movement of vehicles, between curbs or shoulders, including turn lanes, but excluding bike lanes, parking lanes and/or shoulders.
Turn Out	The paved or concrete area outside the roadway or traveled way for a transit vehicle.
Unmaintained Road	A road within the county right-of-way that is accessible to public travel but is not maintained by the County.
Unopened Right-of-Way	A county right-of-way that exists by dedication or deed, but for which no vehicular roadway has been constructed.
Urban Areas	Areas designated in the King County Comprehensive Plan that are characterized by denser commercial, industrial and residential development.
Utility	A privately, publicly, or cooperatively owned line, facility, or system for producing, transmitting, or distributing communications, cable television, power, electricity, light, heat, gas, oil, crude products, water, steam, waste, or any other similar commodity which directly or indirectly serves the public. Additionally, the privately, publicly, or cooperatively owned company that owns the line, facility, or system.

Walkway	A facility designated for pedestrian and non-vehicular traffic. Walkways are typically constructed of asphalt. Separation from vehicle traffic may be provided by pavement striping, curbing, a ditch or open space.
WSDOT	Washington State Department of Transportation.
3-R	Resurfacing, restoration, and rehabilitation of existing roadways with minimal changes to alignment or grade.
2-R	Resurfacing and restoration of existing roadways by supplementing the existing road prism.

CHAPTER 2. ROAD TYPES AND GEOMETRICS

2.01 Road Classifications

County roads are classified functionally as indicated in Sections 2.02 and 2.03. Function is the controlling element for classification and shall govern right-of-way, road width and road geometric. Other given elements such as access, arterial spacing, and average daily traffic count (ADT) are typical. It is necessary to classify streets for purposes of traffic operations, control, and enforcement. Typically, arterials will have higher speed limits and more stringent traffic control measures at intersections, (e.g., traffic signals or stop signs), than non-arterials. In planning, functional classification establishes the hierarchy of roads and highways necessary for a complete transportation system that serves all types of travel needs. Each road has a specified function that produces a comprehensive network for travel and access throughout an area, when combined with the rest of the system. Within each functional classification, roads are further characterized as urban or rural.

Land Developments in Urban Areas. Land developments in urban areas as defined by the current King County Comprehensive Plan Map shall provide "curb" type road improvements unless otherwise specified in these Standards, figures 2-002 and 2-003. A curb type road typically requires an underground pipe storm drainage system with curb, gutter, and sidewalks. Exceptions to this may be approved by the Development Engineer on residential access streets that are located in long-term, low-density neighborhoods and where a pattern of "shoulder" type roads is firmly established. Exceptions for two-lot urban short plats are as allowed in Section 2.05(A).

Land Developments in Rural Areas. Land developments in rural areas as defined by the current King County Comprehensive Plan shall provide "shoulder" type road improvements, unless otherwise specified by these Standards or approved by the County Road Engineer or the Development Engineer, figure 2-001. Certain exceptions to the "shoulder" type standard may apply within clustered housing developments and rural activity centers (unincorporated rural towns such as Vashon or Fall City) where urban densities and uses may make a "curb" type road appropriate, figures 2-002, 2-003 and 2-005. Within these developments, the specifically authorized land uses or business district design guidelines may provide for either a "curb" or "shoulder" type road section.

The rural area is comprised of all lands in King County outside the designated Urban Growth Area (UGA), and does not include the designated Forest and Agricultural Production Districts. The rural area is generally located east of the UGA, with the exception of the rural cities and their UGAs, and also includes the entirety of Vashon-Maury Islands. Within the rural area, the following land use categories are applied: Rural, allowing low-density residential development, forestry, farming, and a range of traditional rural uses; Rural town, recognizing historical settlement patterns and allowing commercial uses to serve rural residents; and Rural Neighborhood, allowing small scale convenience services for nearby rural residents.

Rural development can consist of a variety of uses that are consistent with the preservation of rural character and the requirements of the rural element. Rural development does not refer to agriculture or forestry activities that may be conducted in rural areas.

Land Development in Resource Land Areas. Land development in resource land areas as defined by the current King County Comprehensive Plan shall generally provide “shoulder” type road improvements. The actual land use and development proposal will ultimately define the roadway requirements, figures 2-001 and 2-004.

2.02 Rural Roadways

A. Rural Principal Arterial

Rural principal arterials provide primary connections between rural areas and also distribute traffic between rural and urban areas. They provide the highest degree of mobility; therefore, direct access to abutting properties is very restricted. They generally serve major centers of activity, highest traffic volume corridors and intra-area travel between business districts, communities and rural town centers.

B. Rural Minor Arterial

Rural minor arterials interconnect with and augment the principal arterial system. They provide intra-community continuity connecting community centers and facilities. A rural minor arterial is typically a continuous road with a direct alignment. Access is partially restricted.

C. Rural Collector Arterial

Rural collector arterials typically are intra-community roadways connecting cities or towns, residential neighborhoods and community centers and facilities. They provide connections between rural local roads and other roadways that are higher in the hierarchy of classification. Access is partially restricted.

D. Low Volume Collector Arterial

Low volume rural collectors are intra-community arterials with an average daily traffic (ADT) of four hundred or less that connects residential neighborhoods with small communities. They generally provide connections between rural local roads.

E. Rural Local Roadways

There are several roadway classifications for rural local roadways. Typically "shoulder" type road improvements are provided in the rural area unless otherwise approved by the County Road Engineer or the Development Engineer. The rural local roadway classifications are listed below:

1. Neighborhood Collectors

Neighborhood collector streets are the highest in the local roadway classification hierarchy. They connect two or more neighborhoods and typically connect to arterials or other neighborhood collectors. Direct driveway connections to neighborhood collectors are restricted.

2. Subcollectors

Subcollector streets are the second highest in the local roadway classification hierarchy. They are typically two-lane asphalt roadways. They provide circulation within neighborhoods and typically connect to neighborhood collectors. Although subcollectors typically allow direct driveway access there are some project related exceptions.

3. Subaccess

Subaccess streets are permanent cul-de-sacs or short loop streets that connect to subcollectors. Subaccess streets are not supportive of through traffic. They are typically internal subdivision roadways that provide circulation within the subdivision. Direct driveway connections are allowed.

4. Minor Access

A minor access street is a permanent cul-de-sac or short loop street with low traffic volumes that provides circulation and access to off-street parking within a residential development boundary. Like subaccess streets, a minor access street allows direct driveway connections.

F. Rural Commercial Access Streets

There are several roadway classifications for rural commercial access streets.

1. Attached-Dwelling Access

Attached-dwelling access streets typically serve town houses, condominiums, apartments, and other multiple-dwelling developments.

2. Business Access

Business access streets typically serve very dense multiple-dwelling developments, office buildings, and other professional service buildings.

3. Industrial Access

Industrial access streets typically serve manufacturing, processing, storing and handling activities. These roadways generally route industrial vehicles from the arterial system to and within industrial districts.

4. Commercial Minor Access

Commercial minor access streets provide circulation and access to parking and loading sites within multiple-dwelling, business, and industrial developments.

G. Primitive Road. A primitive road is a road within county right-of-way that meets the criteria of RCW 36.75.300. These roadways are not part of the

county primary road system and must be designated primitive by the County Council. A primitive road must be identified with signs, as provided in the Manual of Uniform Traffic Control Devices, at all locations where the primitive road begins or connects to a non-primitive road.

2.02(A) Rural Arterials (Shoulder Roadway Section)

Classification	Principal	Minor	Collector	Low Volume Collector
Access	Controlled with very restricted access to abutting properties.	Partially controlled with infrequent access to abutting properties.	Partially controlled with infrequent access to abutting properties.	As needed with some restrictions to abutting properties.
Arterial Spacing ¹	2 to 5 miles	Under 2 Miles	Under 2 miles	-
Design Speed ²	Varies 40 to 60mph	Varies 35 to 55mph	Varies 35 to 50mph	Varies 35 to 50mph
Horizontal Curvature	See Table 2.1	See Tale 2.1	See Table 2.1	See Table 2.1
Maximum Grade ³	9%	10%	12%	12%
Typical Traveled Way ⁴	22 to 56 feet	22 to 56 feet	22 to 44 feet	22 feet
Typical Roadway Width ⁴	38 to 72 feet	38 to 72 feet	34 to 60 feet	30 feet
Typical Lane Width	11 feet	11 feet	11 feet	11 feet
Typical Left Turn Lane Width	12 feet	12 feet	12 feet	-
Typical Right Turn Lane Width	12 feet	12 feet	12 feet	-
Superelevation ⁵	6%	6%	6%	6%
Minimum Stopping Sight Distance	See Table 2.1	See Table 2.1	See Table 2.1	See Table 2.1
Minimum Entering Sight Distance	See Table 2.1	See Table 2.1	See Table 2.1	See Table 2.1
Minimum Passing Sight Distance	See Table 2.1	See Table 2.1	See Table 2.1	See Table 2.1
Minimum Right-of-Way Width ⁴	100 feet	84 feet	60 to 84 ⁶ feet	60 feet
Typical Shoulder Width ⁷	8 feet	8 feet	6 to 8 feet	4 feet

¹ For arterial spacing, distances are given only as general guidelines.

² Design speed is a basis for determining geometric elements and does not imply posted or legally permissible speed.

³ Maximum grade may be exceeded for short distances.

⁴ Criteria for federal and state funding may require greater traveled way, roadway, and right-of-way widths. Greater widths also may be required for the construction of bike lanes, equestrian trails, and other non-motorized use.

⁵ See Section 2.04 for allowed use of superelevations greater than 6 percent.

⁶ Four-lane roadway.

⁷ For guardrail installation, shoulders shall be two-feet wider.

2.02(B) Rural Residential Access Roadways - (Shoulder Roadway Section)

Classification	Neighborhood Collectors	Subcollectors	Subaccess	Minor Access
Access	Restricted, Lots front on local access street where feasible.	As needed with some restrictions.	Permanent cul-de-sacs or short loop streets ¹ that connects to subcollectors. Subaccess streets are not supportive of through traffic.	Permanent cul-de-sacs or short loops ¹ with low traffic volumes that provide circulation and access to off-street parking within residential development boundaries.
Public or Private	Public Streets	Public Streets	Public Streets	Public or Private (See Section 2.06)
Serving Potential Number of Lots or Dwelling Units	Over 100 ²	100 Maximum ³	50 Maximum	16 Maximum
Design Speed ⁴	35 mph	30 mph	Low Speed Curve (See Section 2.10)	Low Speed Curve (See Section 2.10)
Max Superelevation	6%	6%	See Section 2.04 (B)	See Section 2.04 (B)
Horizontal Curvature	See Table 2.1	See Table 2.1	Low Speed Curve (See Section 2.10)	Low Speed Curve (See Section 2.10)
Maximum Grade ⁵	11%	12%	12%	12%
Minimum Stopping Sight Distance	See Table 2.1	See Table 2.1	150 feet	150 feet
Minimum Entering Sight Distance	See Table 2.1	-	-	-
Typical Traveled Way ⁶	22 feet	22 feet	20 feet	20 feet
Typical Roadway Width ⁶	38 feet	34 feet	28 feet	24 feet
Minimum Right-of-Way Width ⁶	60 feet	60 feet	48 feet	48 feet
Minimum Shoulder Width ⁷	8 feet	6 feet	4 feet	2 feet
Minimum Half Street Width	20 feet	20 feet	20 feet	20 feet
Minimum One Way Paved Width	20 feet	20 feet	20 feet	20 feet

¹ See Section 2.15 for one-way loop streets.

² See Section 2.20 for residential access connection requirements.

³ See Section 2.21 for exception criteria.

⁴ Design speed is a basis for determining geometric elements and does not imply posted or legally permissible speed.

⁵ Maximum grade may be exceeded for short distances. (See Section 2.11)

⁶ Greater traveled way, roadway, and road right-of-way widths may be required for the construction of bike lanes, equestrian trails, and other non-motorized use.

⁷ For guardrail installation, shoulders shall be two-feet wider.

2.02(C) Commercial Access Streets (Shoulder Roadway Section)

Classification	Attached- Dwelling Access Streets	Business Access Streets	Industrial Access Streets	Minor Access Streets
Access	As needed with some regulation.	As needed with some regulation.	As needed with some regulation.	As needed with only minimal restrictions.
Public or Private Street	Typically public streets serving R-12 - R-24 zones.	Typically public streets serving R-48, NB, CB & O zones.	Typically public streets serving RB & I zones	Public or private streets.
Design Speed ¹	35 mph	35 mph	35 mph	Low Speed Curve – See Sec 2.10
Maximum Superelevation	6%	6%	6%	-
Horizontal Curvature	See Table 2.1	See Table 2.1	See Table 2.1	Low Speed Curve – See Sec 2.10
Maximum Grade ²	12%	12%	11%	12%
Minimum Stopping Sight Distance ³	See Table 2.1	See Table 2.1	See Table 2.1	150 feet
Minimum Entering Sight Distance ⁴	See Table 2.1	See Table 2.1	See Table 2.1	-
Typical Traveled Way	22 feet	24 feet	24 feet	20 feet
Typical Roadway Width ⁵	38 feet	40 feet	40 feet	28 feet
Minimum Right-of-Way Width	60 feet	60 feet	60 feet	48 feet
Minimum Shoulder Width	8 feet	8 feet	8 feet	4 feet
Minimum Half-Street Width	20 feet	20 feet	20 feet	20 feet
Minimum One-Way Paved Width	20 feet	22 feet	24 feet	20 feet

¹ Design speed is a basis for determining geometric elements and does not imply posted or legally permissible speed.

² Maximum grade may be exceeded for short distances. (See Section 2.11).

³ Standard Stopping Sight Distance (SSD) shall apply unless otherwise approved by the County Road Engineer. (See Section 2.12).

⁴ Standard Entering Sight Distance (ESD) shall apply at intersections and driveways except on minor access streets unless otherwise approved by the County Road Engineer.

⁵ For guardrail installation, shoulders shall be two feet wider.

2.03 Urban Roadways

A. Urban Principal Arterial

Urban principal arterials provide for movement across and between large subareas of an urban region and serves predominantly “through traffic.” They carry the highest traffic volume and serve major centers of activity and are fed by other arterials and local access streets. Principals are expected to provide a high degree of mobility; therefore, access to abutting properties is very restricted.

B. Urban Minor Arterial

Urban minor arterials interconnect with and augment the principal arterial system. They provide intra-community continuity connecting community centers and facilities. A minor arterial may also serve “through traffic”. Access is partially restricted.

C. Urban Collector Arterial

Urban collector arterials typically are intra-community roadways connecting residential neighborhoods with community centers and facilities. They accumulate traffic from local roadways and distribute that traffic to roadways that are higher in the hierarchy of classification. Access is partially restricted.

D. Urban Local Roadways

There are several roadway classifications for urban local roadways. They are listed below:

1. Neighborhood Collectors

Neighborhood collector streets are the highest in the local roadway classification hierarchy. They connect two or more neighborhoods and typically connect to arterials or other neighborhood collectors. Direct driveway connections to neighborhood collectors are restricted.

2. Subcollectors

Subcollector streets are the second highest in the local roadway classification hierarchy. Subcollectors provide circulation within neighborhoods and typically connect to neighborhood collectors. Although they typically allow direct driveway access there are some project related exceptions.

3. Subaccess

Subaccess streets are permanent cul-de-sacs or short loop streets that connect to subcollectors. Subaccess streets are not supportive of through traffic. They provide direct driveway connections.

4. Minor Access

A minor access street is a permanent cul-de-sac or short loop street with low traffic volumes that provides circulation and access to off-street parking within a residential development boundary. Like subaccess streets, a minor access street allows direct driveway connections.

E. Urban Commercial Access Streets

There are several roadway classifications for urban commercial access streets. Typically "curb" type road improvements are provided along these streets unless otherwise approved by the County Road Engineer or the Development Engineer. The classifications are listed below:

1. Attached-Dwelling Access

Attached-dwelling access streets typically serve town houses, condominiums, apartments, and other multiple-dwelling developments.

2. Business Access

Business access streets typically serve very dense multiple-dwelling developments, office buildings, and other professional service buildings.

3. Industrial Access

Industrial access streets typically serve manufacturing, processing, storing and handling activities. These roadways generally route industrial vehicles from the arterial system to and within industrial districts.

4. Commercial Minor Access

Commercial minor access streets provide circulation and access to parking and loading sites within multiple-dwelling, business, and industrial developments.

2.03(A) Urban Arterials (Curb Roadway Section)

Classification	Principal	Minor	Collector
Access	Controlled with very restricted access to abutting properties.	Partially controlled with infrequent access to abutting properties.	Partially controlled with infrequent access to abutting properties.
Arterial Spacing ¹	2 to 5 miles	Under 2 Miles	Under 2 miles
Design Speed ²	Varies 40 to 60mph	Varies 35 to 55mph	Varies 35 to 50mph
Horizontal Curvature	See Table 2.1	See Table 2.1	See Table 2.1
Maximum Grade ³	9%	10%	12%
Typical Traveled Way ⁴	44 to 56 feet	44 to 56 feet	36 to 44 feet
Typical Roadway Width ⁴	44 to 66 feet	44 to 66 feet	44 to 54 feet
Typical Lane Width	11 feet	11 feet	11 feet
Typical Left Turn Lane Width	12 feet	12 feet	12 feet
Typical Right Turn Lane Width	12 feet	12 feet	12 feet
Typical Widen Curb Lane Width ⁶	14 feet	14 feet	14 feet
Typical Bike Lane Width	5 feet	5 feet	5 feet
Maximum Superelevation ⁵	6%	6%	6%
Minimum Stopping Sight Distance	See Table 2.1	See Table 2.1	See Table 2.1
Minimum Entering Sight Distance	See Table 2.1	See Table 2.1	See Table 2.1
Minimum Passing Sight Distance	See Table 2.1	See Table 2.1	See Table 2.1
Minimum Right-of-Way Width ⁴	100 feet	84 feet	84feet
Minimum Sidewalk Width	See Section 3.02	See Section 3.02	See Section 3.02
Curb Type	Vertical	Vertical	Vertical

¹ For arterial spacing, distances are given only as general guidelines.

² Design speed is a basis for determining geometric elements and does not imply posted or legally permissible speed.

³ Maximum grade may be exceeded for short distances.

⁴ Criteria for federal and state funding may require greater traveled way, roadway and right-of-way widths. Greater widths also may be required for the construction of bike lanes, equestrian trails, and other non-motorized use.

⁵ See Section 2.04 for allowed uses of superelevations greater than 6 percent.

⁶ A widen curb lane is provided to accommodate bicycles.

2.03(B) Urban Residential Access Roadways - (Curb Roadway Section)

Classification	Neighborhood Collectors	Subcollectors	Subaccess	Minor Access
Access	Restricted, Lots front on local access street where feasible.	As needed with some restrictions. ¹	Subaccess streets are not supportive of through traffic. Generally permanent cul-de-sacs or short loop ² streets that connects to subcollectors.	Permanent cul-de-sacs or short loops with low traffic volumes that provide circulation and access to off-street parking within residential development limits.
Public or Private	Public Streets	Public Streets	Public Streets	Public or Private (See Section 2.06)
Serving Potential Number of Lots or Dwelling Units	Over 100 ³	100 Maximum ⁴	50 Maximum	16 Maximum
Design Speed ⁵	35 mph	30 mph	Low Speed Curve (See Section 2.10)	Low Speed Curve (See Section 2.10)
Max Superelevation	See Section 2.04B	See Section 2.04B	See Section 2.04B	See Section 2.04B
Horizontal Curvature	See Table 2.2	See Table 2.2	Low Speed Curve (See Section 2.10)	Low Speed Curve (See Section 2.10)
Maximum Grade ⁶	11%	12%	12%	12%
Minimum Stopping Sight Distance	See Table 2.2	See Table 2.2	0 feet	150feet
Minimum Entering Sight Distance	See Table 2.2	-	-	-
Typical Traveled Way	22 feet ⁷	22 feet	22 feet	22 feet
Typical Roadway Width	32 feet ⁷	28 feet	24 feet	22 feet
Minimum Right-of-Way Width	56 feet	48 feet	40 feet ⁸	40 feet ⁸
Minimum Half Street Width	20 feet	20 feet	20 feet	20 feet
Minimum One Way Paved Width	20 feet	20 feet	20 feet	20 feet
Minimum Sidewalk Width	See Section 3.02	See Section 3.02	See Section 3.02	See Section 3.02
Curb Type	Vertical	Vertical ¹ /Rolled	Vertical/Rolled	Vertical/Rolled

¹ See Section 2.21 for urban exceptions. Also, when Section 2.21 applies the curbing shall be vertical.

² See Section 2.15 for one-way loops.

³ See Section 2.20 for residential access connection requirements.

⁴ See Section 2.21 for urban exception criteria.

⁵ Design speed is a basis for determining geometric elements and does not imply posted or legally permissible speed.

⁶ Maximum grade may be exceeded for short distances. See Section 2.11.

⁷ Neighborhood collectors intersecting with arterials shall be 36 feet wide for the first 150 feet. See Section 4.05 for tapers.

⁸ The right-of-way width may be reduced to minimum roadway width plus storm drainage, sidewalk, and one-foot beyond road improvements including sidewalks, provided that the curbing is vertical, the minimum clear zone requirements are met, and all potential serving utilities are accommodated within permanent public easements.

2.03(C) Commercial Access Streets (Curb Roadway Section)

Classification	Attached Dwelling Access Streets	Business Access Streets	Industrial Access Streets	Minor Access Streets
Access	As needed with some regulation.	As needed with some regulation.	As needed with some regulation.	As needed with only minimal restrictions.
Public or Private Street	Typically public streets serving R-12 through R-24 zones.	Typically public streets serving R-48, NB, CB, & O zones.	Typically public streets serving RB & I Zones	Public or private streets.
Design Speed ¹	35 mph	35 mph	35 mph	Low Speed Curve - See Section 2.10
Maximum Superelevation	6%	6%	6%	-
Horizontal Curvature	See Table 2.1	See Table 2.1	See Table 2.1	Low Speed Curve - See Section 2.10
Maximum Grade ²	12%	12%	11%	12%
Minimum Stopping Sight Distance ³	See Table 2.1	See Table 2.1	See Table 2.1	150 feet
Minimum Entering Sight Distance ⁴	See Table 2.1	See table 2.1	See Table 2.1	-
Typical Traveled Way	36 feet	36 feet	40 feet	24 feet
Typical Roadway Width	36 feet	36 feet	40 feet	24 ⁵ feet ⁴
Minimum Right-of-Way Width	56 feet	56 feet	60 feet	40 ⁵ feet
Minimum Sidewalk Width	See Section 3.02	See Section 3.02	See Section 3.02	See Section 3.02
Minimum Half-Street Width	20 feet	20 feet	20 feet	20 feet
Minimum One-Way Paved Width	20 feet	22 feet	24 feet	20 feet
Curb Type	Vertical	Vertical	Vertical	Vertical

¹ Design speed is a basis for determining geometric elements and does not imply posted or legally permissible speed.

² Maximum grade may be exceeded for short distances. See Section 2.11.

³ Standard Stopping Sight Distance (SSD) shall apply, unless otherwise approved by the County Road Engineer. See Section 2.12.

⁴ Standard Entering Sight Distance (ESD) shall apply at intersections and driveways except when a driveway intersects a minor access street, unless otherwise approved by the County Road Engineer.

⁵ The right-of-way may be reduced to minimum roadway width, plus storm drainage, sidewalk, one-foot behind sidewalk, provided that the curbing is vertical, the minimum clear zone requirements are met, and potential serving utilities are accommodated within permanent public easements.

2.04 Horizontal Curvature and Sight Distance Design Values

- A. The values shown in Tables 2.1 and 2.2 are minimum design values. A maximum of 8 percent superelevation may be used, upon approval of the County Road Engineer, for design of improvements to existing arterials, as necessary, to meet terrain and right-of-way conditions. Superelevation run-off lengths on arterials, rural residential and commercial access streets shall be calculated in accordance with the WSDOT Design Manual.
- B. Superelevation is not required in the design of horizontal curves on urban residential access streets; however, horizontal curves must be designed based on design speed and selected cross section as indicated in Table 2.2. This table is based on AASHTO "Low Speed Urban Streets" design methodology. Superelevation may be used on urban residential streets as necessary to meet terrain and right-of-way conditions.

Table 2.1
Arterial Roads, Rural Residential And Commercial Access Streets
Design Values¹

Design Speed (mph)	30	35	40	45	50	55	60
Horizontal Curvature for 6% (<i>maximum allowable on neighborhood collectors and local access streets</i>) Superelevation, Radius (Ft.)	275	380	510	650	835	1,065	1,340
Horizontal Curvature for 8% (<i>maximum allowable on arterials</i>) Superelevation, Radius (Ft.) (requires approval of the County Road Engineer)	250	350	465	600	760	965	1,205
Stopping Sight Distance (Ft.)	200	250	305	360	425	495	570
Entering Sight Distance (Ft.) ^{2,3,4}	335	390	445	500	555	610	665
Passing Sight Distance (Ft.) for a 2-Lane Road	1,090	1,280	1,470	1,625	1,835	1,985	2,135

¹ See Section 2.12.

² See Section 2.14. Entering sight distance shown is for a stopped passenger vehicle to turn left onto a two-lane highway with no median and grades 3 percent or less. For other conditions the time gap must be adjusted and required sight distance recalculated. (See 2001 AASHTO – Intersection Control section).

³ For multilane roadways: For left turns onto two-way roadways with more than two lanes, add 0.5 seconds for passenger cars or 0.7 seconds for trucks for each additional lane from the left, in excess of one, to be crossed by the turning vehicle.

⁴ For minor and approach grades: If the approach grade is an upgrade that exceeds 3 percent; add 0.2 seconds for each percent grade for left turns.

Table 2.2
Urban Residential Access Streets Design Values

Design Speed (mph)	25	30	35
Horizontal Curvature, for 6% Superelevation, Radius (Ft.)	135	215	320
Horizontal Curvature, for 4% Superelevation, Radius (Ft.)	145	230	345
Horizontal Curvature, for 2% Superelevation, Radius (Ft.)	155	250	375
Horizontal Curvature, Normal Crown Section, Radius (Ft.)	180	300	460
Stopping Sight Distance (Ft.)	155	200	250
Entering Sight Distance (Ft.)	280	335	390

2.05 Short Plats

This section is limited to residential short subdivisions of four lots or less. King County will not accept streets for maintenance within short plats when the roads providing access to the short plat are private and already have the potential to serve more than the number of lots specified in Section 2.06.

A. Urban Residential Short Plats

1. When an urban residential short plat adds one additional lot to an existing lot that already has a permitted habitable residential dwelling unit, a paved shoulder may be constructed along the short plat frontage as an alternative to curb, gutter, and sidewalk improvements, provided:
 - a. The surrounding roadways frontage improvements are of rural character; and,
 - b. The potential development of the neighborhood is low and consists primarily of in-fill.
2. When the short plat access street extends more than 150 feet measured from the centerline of the nearest street intersection and serves or will serve more than two lots, a turnaround shall be provided. The turnaround may be a cul-de-sac or a hammerhead.
3. The total roadway width shall be 20 feet and the surfacing shall be asphalt.
4. The geometric design criteria shall meet the requirements of a residential minor access roadway.

B. Rural Residential Short Plats

1. When the short plat access street extends more than 150 feet measured from the centerline of the nearest street intersection and serves or will serve more than two lots, a turnaround must be provided. The turnaround may be a cul-de-sac or hammerhead.
2. The total roadway width (traveled way and shoulders) shall be 20 feet.
3. The geometric design criteria shall meet the requirements of a residential minor access roadway.
4. The roadway surfacing may be gravel, bituminous, or asphalt.

2.06 Private Streets

- A. While public streets, owned and maintained by the County, usually best serve community street requirements, private streets may be appropriate for some local access streets. Usually these are minor access streets, either residential or commercial.
- B. Private streets may be approved only when they are:
 1. Permanently established by right-of-way, tract or easement providing legal access to each affected lot, dwelling unit, or business and sufficient to accommodate required improvements, to include provision for future use by adjacent property owners when applicable; and
 2. Built to the Standards, as set forth herein, and
 3. Accessible at all times for emergency and public service vehicle use; and
 4. Not obstructing, or part of, the present or future public neighborhood circulation plan developed in processes such as the King County Comprehensive Plan, King County Transportation Plan, or Capital Improvement Program; and
 5. Not going to result in land locking of present or future parcels; and
 6. Not needed as public roads to meet the minimum road spacing requirements of these Standards; and
 7. Designed to serve a maximum potential of 16 single-family dwelling units when the entire length of the private road system to the nearest public maintained road is considered. The maximum potential is the number of dwelling units that can possibly be served by the road when physical barriers, zoning or other legal constraints are considered; and
 8. Maintained by a capable and legally responsible owner or homeowners' association or other legal entity made up of all benefited property owners; and
 9. Clearly described on the face of the plat, short plat, binding site plan, site development permit or other development authorization and clearly signed at street location as a private street, for the maintenance of which King County is not responsible.

- C. King County will not accept private streets for maintenance as public streets until such streets are brought into conformance with current King County Code and these Standards.
- D. Best Management Practices (BMP'S) should be used when maintaining private roadways.
- E. King County will not accept private streets within short plats when the roads providing access to the plat are private and already have the potential to serve more than the number of lots specified in Section 2.06(B.7). If a short plat has been proposed on a property to which the only access is over private streets that fail to meet the standards specified in this section, the proposal shall be denied.

2.07 Half Streets

- A. A half street, figure 2-009, may be permitted as an interim facility when:
 - 1. Such street shall not serve as primary access to more than 35 dwelling units or equivalent ADT; and
 - 2. Such alignment is consistent with or will establish a reasonable circulation pattern; and
 - 3. There is reasonable assurance of obtaining the prescribed additional right-of-way from the adjoining property with topography suitable for completion of a full-section road.
- B. A half street shall meet the following requirements:
 - 1. Right-of-way width of the half street shall be a minimum width of thirty (30) feet and sufficient to construct the roadway and related grading; and
 - 2. The half street shall be graded consistent with locating the centerline of the ultimate road section as close as possible to the property line; and
 - 3. Traveled way shall be surfaced the same as the designated road type to a width not less than 20 feet, sidewalk shall be constructed as required for the designated road type; and
 - 4. Property line edge of street shall be finished with temporary curbing, shoulders, ditches, and/or side slopes in order to assure proper drainage, bank stability, and traffic safety; and
 - 5. Half streets shall not intersect other half streets or exceed these requirements unless so approved by the County Road Engineer, and
 - 6. The intersection of a half street shall be improved to full width standards, and
 - 7. Half-streets shall meet the requirements of Section 4.03 of these Standards.
- C. When a half street is eventually completed to a whole street, the completing builder shall reconstruct the original half street as necessary to produce a proper full-width crowned street of a designated section.

- D. Obtaining any right-of-way or easements to accomplish the above shall be the responsibility of the applicant or developer.

2.08 Cul-de-sacs, Islands, and Hammerheads

- A. Cul-de-sacs: Whenever a dead-end street serves or will serve more than six lots or extends more than 150 feet from centerline of accessing street to farthest extent of surfaced traveled way, a widened "bulb," figure 2-006 shall be constructed as follows:

1. Minimum right-of-way diameter across bulb section: 100 feet in a permanent cul-de-sac; 84 feet in a temporary cul-de-sac, with bulb area lying outside straight-street right-of-way provided as temporary easement pending forward extension of the street. Right-of-way may be reduced, provided utilities and necessary drainage are accommodated on permanent easements within the development. See Section 2.19.
2. Minimum diameter of surfacing across bulb: 80 feet of paving in curb-type road; 80 feet total in shoulder-type road to include 64 feet of paving and eight-foot shoulders with compacted crushed surfacing material.
3. Where required on cul-de-sacs, sidewalks shall be constructed on both sides.
4. A permanent cul-de-sac shall not be longer than 600 feet measured from centerline of intersecting loop or through street to the center of the bulb section. On the basis of pertinent traffic planning factors such as topography, sensitive areas and existing development, the County Road Engineer will consider variances to this requirement.
5. The County Road Engineer or Development Engineer may require an emergency vehicle access and/or an off-street walkway to connect a cul-de-sac at its terminus with other streets, parks, schools, bus stops, or other pedestrian traffic generators.
6. If a street temporarily terminates at a property boundary, serves or will serve more than six lots, or is longer than 150 feet, a temporary bulb shall be constructed near the development boundary. The paved bulb shall be 80 feet in diameter with sidewalks terminated at the point where the bulb radius begins. Removal of the temporary constructed cul-de-sac and construction of the extension of the sidewalk shall be the responsibility of the applicant/developer who extends the road. See figure 2-007.
7. The maximum cross slope in a bulb shall not exceed 6 percent in any direction.
8. Partial bulbs or eyebrows shall have a minimum paved radius and an island configuration as shown on figure 2-008. Island shall be offset two feet from edge of roadway.

9. Temporary cul-de-sac easements are extinguished, when applicable, through the right-of-way vacation process in accordance with King County Code 14.40.
 10. When a commercial access street change from a public to private designation a public turnaround shall be required, regardless whether another fire access turnaround is provided elsewhere, except as noted in Section 2.08(A).
- B. Cul-de-sac Island: A cul-de-sac island is an optional feature for any cul-de-sac when bulb paved diameter is 80 feet or less; mandatory when bulb paved diameter exceeds 80 feet. If provided, island shall have full-depth cement concrete vertical curb and gutter. Minimum diameter shall be 20 feet and there shall be at least 22 feet of paved traveled way in a shoulder-type section; 30 feet of paved traveled way in a curb-type section around the circumference. An island shall be grassed or landscaped. The adjoining property owners are responsible for the landscaped and or grassed area within the island.
- C. Hammerheads: A hammerhead may be used to satisfy the turnaround requirements where a private street serves or will serve 4 or fewer lots. See figure 2-011.

2.09 Alleys and Private Access Tracts

The geometric design criteria for subaccess streets shall be used to design alleys. An alley is considered a private road that provides secondary access.

A. Alleys

1. An alley shall serve a maximum of 30 dwelling units, with a maximum length of 400 feet, no dead ends or cul-de-sacs.
2. The tract width shall be sufficient to construct the alley and related grading. The minimum tract width shall be 20 feet with a pavement surface width of 18 feet (including curb) based on a 5-foot structure setback. For differing structure setback requirements, the alley surfacing width shall be designated to provide for safe turning access to properties.
3. Paved surface shall have a curb on one side (rolled, vertical, extruded, or thickened edge) and cross slope in one direction to control surface runoff. It shall be a minimum length of 20 feet. See figure 2-010.
4. Public streets to which an alley connects or which provide access to the front boundary of the properties served by the alley shall be 28-foot minimum paved width with vertical curb. Where connecting streets are curb type sections, driveway cuts shall be required.
5. Modifications to existing alleys serving commercial or industrial properties, in accordance with the above, will be determined on a case-by-case basis subject to approval by the Development Engineer.
6. Alleys shall not intersect other alleys.

B. Private Access Tracts

Private access tracts shall meet the geometric design criteria for minor access streets and the following:

1. A private access tract shall serve a maximum of six dwelling units.
2. Minimum tract width of 20 feet with a maximum length of 150 feet, measured from centerline of intersecting street to furthest extent of paved tract.
3. Pavement width shall be a minimum of 18 feet including curb (rolled, vertical, extruded, or thickened edge) and gutter in urban areas.
4. Easements may be required for utilities and drainage.

2.10 Intersections and Low-Speed Curves

A. Intersections

- | | |
|---|--|
| 1. Angle of intersection (measured at 10 feet beyond road classification right-of-way) | Minimum 85 degrees
Maximum 95 degrees |
| 2. Minimum centerline radius (2-lane) (radii are for minor or subaccess streets) | 55 feet |
| 3. Minimum curb radius | |
| a. Arterials and roads classified neighborhood collector or higher: | 35 feet |
| b. Residential access street intersections where the highest classification involved is subcollector: | 25 feet |
| 4. Minimum right-of-way line radius: | 25 feet |

B. Spacing between adjacent intersecting streets, whether crossing or T-connecting, shall be as follows:

When highest classification involved is:	Minimum centerline offset shall be:
Principal arterial	1,000 feet
Minor arterial	500 feet
Collector arterial	300 feet
Neighborhood collector	150 feet
Any lesser street classification	100 feet

- C. On sloping approaches at an intersection, landings shall be provided with grade not to exceed one foot difference in elevation for a distance of 30 feet approaching an arterial or 20 feet approaching a residential or commercial street, measured from future right-of-way line (intersected by an imaginary 2 percent grade extended from crowned road to right-of-way line) of intersecting street as provided in Section 2.02 or 2.03. See figure 2-013.
- D. Roundabout intersections taking the place of standard intersections shall be designed in accordance with current USDOT/FHWA guidelines and the WSDOT Design Manual.
- E. Entering Sight Distance. See Sections 2.02, 2.03, 2.04 and 2.14 for design requirements. See Tables 2.1 or 2.2 for specific entering sight distance values based on required design speed.
- F. Low Speed Curves: applicable to subaccess and minor access streets only. See Sections 2.03 and 2.04.

	Up to 75°	75° & Over
1. Minimum centerline radius (two-lane):	100 feet	55 feet
2. Minimum curb radius:	80 feet	35 feet ¹
3. Minimum right-of-way line radius:	70 feet	25 feet

2.11 Maximum Grade and Grade Transitions

- A. Maximum roadway grade as shown in Sections 2.02 and 2.03 may be exceeded for short distances of 300 feet or less, upon showing that no practical alternative exists. Exceptions, which exceed 12 percent, will require verification by the Fire Marshal that additional fire protection requirements will be met and show what method will be used to ensure drainage will be controlled. Grades exceeding 12 percent shall be paved with asphalt or Portland cement concrete (PCC). The grade shall not exceed 15 percent.
- B. Grade transitions shall be constructed as smooth vertical curves, without angle points, except in intersections where the difference in grade is one percent or less and upon approval of the County Road Engineer or Development Engineer.

2.12 Stopping Sight Distance

- A. Stopping Sight Distance (SSD) is the sum of two distances: the distance traveled during perception and reaction time and the distance required to stop the vehicle. The perception and reaction time used in design is 2.5 seconds. The stopping sight distance is calculated using a constant deceleration rate of 11.2 feet/second². SSD, see Tables 2.1 and 2.2, applies to street classifications as shown in Sections 2.02 and 2.03.

¹ On residential access street intersections where the highest classification involved is a subcollector, the minimum curb radius is 25 feet.

- B. Available stopping sight distance is calculated for a passenger car using an eye height of 3.50 feet and an object height of 0.50 foot. Although AASHTO allows a 2-foot object height, a 0.50-foot object height is used because objects with a height between 0.5-foot and 2 feet may be perceived as hazards that would likely result in an erratic maneuver.
- C. When using AASHTO crest vertical curve equation, see page 271 of the 2001 AASHTO green book, to calculate sight distance, use $h_1=3.50$ feet and $h_2=0.50$ foot.
- D. The grade of the roadway has an effect on the vehicle's stopping sight distance. The stopping distance is increased on downgrades and decreased on upgrades. When evaluating sight distance with a changing grade, use the grade for which the longest sight distance is needed. Road grades other than those shown in exhibit 2-1 must be interpolated.

Exhibit 2-1. Stopping Sight Distance on Grades

DESIGN SPEED (MPH)	DOWNGRADE		
	3 Percent	6 Percent	9 Percent
60	598	638	686
55	520	553	594
50	446	474	507
45	378	401	428
40	315	333	354
35	258	271	288
30	205	215	227
25	158	165	173
20	116	120	126

DESIGN SPEED (MPH)	UPGRADE		
	3 Percent	6 Percent	9 Percent
60	538	515	495
55	470	450	433
50	405	388	375
45	345	331	320
40	289	278	269
35	237	229	222
30	200	184	179
25	147	143	140
20	109	107	104

- E. Sag vertical curves on residential or commercial streets that do not meet the minimum SSD may be approved by the Development Engineer if no practical design exists and if acceptable illumination is provided throughout the curve and is maintained by a franchised utility. The design shall include at a minimum 100-watt High Pressure Sodium luminaries, 25-foot mounting height and 100- to 120-foot spacing, throughout the sag curve
- F. Intersecting Stopping Sight Distance.
 - 1. Stopping sight distances for the design speeds of proposed commercial access streets, neighborhood collector streets and arterials must be met when intersecting arterials.
 - 2. The minimum stopping sight distance on proposed intersection approaches for all other access to intersecting roadways shall be 125 feet.

2.13 Entering Sight Distance (ESD)

Entering sight distance applies on driveways and streets approaching intersections as set forth in Sections 2.02 and 2.03 with the exception of subcollectors, subaccess, residential minor access streets, and commercial minor access streets. Specific ESD values for required design speeds are listed in Section 2.04, Tables 2.1 and 2.2.

- A. Entering vehicle eye height is 3.5 feet, measured 10 feet back from edge of traveled way or edge line on rural roadways and ten feet back from face of curb on urban roadways, figure 2-012. Approaching vehicle height is 4.25 feet.
- B. Requirements in Section 2.04, Tables 2.1 and 2.2 apply to an intersection or driveway approach to a typical road under average conditions. In difficult topography the County Road Engineer may authorize a reduction in the ESD based on factors mitigating the hazard. Such factors may include an anticipated posted or average running speed less than the design speed or the provision of acceleration lanes and/or a median space allowing an intermediate stop by an approaching vehicle making a left turn.
- C. Where a significant number of trucks will be using the approach road, the County Road Engineer may increase the entering sight distance requirements by up to 30 percent for single-unit trucks and 70 percent for semi-trailer combinations.

2.14 Medians (Optional Design Feature)

Median width shall be additional to, not part of the specified width of traveled way. Edges shall be similar to outer road edges: either extruded or formed vertical curb; or shoulder and ditch; except that median shoulders shall be four feet in width minimum. Twenty feet of drivable surface (which includes traveled way and paved shoulders, if any) shall be provided on either side of the median. The median may be grassed, landscaped, or surfaced with aggregate or pavement. Median shall be designed so as not to limit turning radii or sight distance at

intersections. No portion of a side street median may extend into the right-of-way for an arterial street. The County Road Engineer or Development Engineer may require revisions to medians as necessary to provide for new access points and to maintain required sight distance. Non-yielding or non-breakaway structures shall not be installed in medians. Street trees may be planted in the median subject to approval by the County Road Engineer.

2.15 One-Way Streets

Local access streets, including loops and bulbs, may be designated one-way upon a finding by the County Road Engineer that topography or other site features make two-way traffic impractical.

2.16 Bus Zones and Turn-Outs

During the design of arterials and neighborhood collectors, the designer shall contact the transit agencies, and the local school district to determine bus zone (stop) locations and other bus operation needs. The project shall provide wheelchair accessible landing pads at designated bus zones, and where required shall include turn-outs and shelter pads. Pedestrian and disabled access improvements within the right-of-way to and from the bus loading zone or turn-out from nearby businesses or residences shall also be provided as part of the road improvement. Surfacing requirements may also be affected, particularly on shoulders. See Section 4.01(B) of the Standards. Metro's publication, "Metro Transportation Facility Design Guidelines," may be applicable.

2.17 Exception to Paving on Rural Minor Access Streets (Residential)

- A. A rural minor access street (residential) that is a private street can be designed and constructed to meet the following standard: It shall be graded and, as minimum treatment, be surfaced full width including shoulders, 24 feet with crushed surfacing material as provided in Section 4.01A and Figure 2-004. See Section 2.05 (B) for exception. Half streets shall be surfaced not less than 20 feet wide. Where connecting to a paved public street the connecting area shall be paved between traveled way and right-of-way line (extended) of the public street or provide a landing that is a minimum length of 20 feet, with a radius that meets the requirements of Section 2.10. Paving shall be in accordance with Section 4.01A or with applicable alternative.
- B. Any rural minor access street (residential) approved under Subsection A above shall remain a private street unless it is upgraded to public street standards at the expense of the applicant/developer or adjoining lot owners, to include hard surface paving, and accepted by the County Road Engineer for public ownership and maintenance.

2.18 Slope, Wall, and Drainage Easements and Right-of-Way Reduction

- A. Easements: Either the functional classification or particular design features of a road may necessitate slope, sight distance, and wall or drainage easements beyond the right-of-way line. The County Road Engineer or Development Engineer may require such easements in conjunction with dedication or

acquisition of right-of-way. The design engineer must document there is sufficient right-of-way to include cuts and fills and necessary clear zone.

- B. Right-of-Way Reduction: The right-of-way width may be reduced to minimum roadway width, plus storm drainage, sidewalk, one-foot behind sidewalk, provided that potential serving utilities are accommodated within permanent public easements. The reduced right-of-way, plus easement, at a minimum shall allow for construction and maintenance of the sidewalks, one-foot behind sidewalk, planting strips, drainage facilities, and sign placement. Additionally, they shall allow for sidewalk widening around mailbox locations.

2.19 Access and Circulation Requirements

No residential street shall serve more than 100 lots or dwelling units unless the street is connected in at least two locations with another street that functions at a level consistent with Sections 2.02 or 2.03. Additionally, every effort shall be made to provide a second access through the building permit process.

- A. The second access requirement may be satisfied through use of connecting a new street to an existing street in an adjacent neighborhood if:
 - 1. No other practical alternative exists, or
 - 2. Existing street was previously stubbed indicating intent for future access, or
 - 3. An easement has been recorded specifically for said purpose.
- B. The second access requirement may cause the construction of an off-site road connecting the development to a suitable serving street.
- C. These provisions are not intended to preclude the state statute on land locking.
- D. This section does not preclude a non-residential project from gaining access through a residential development. Traffic impacts for such projects will be analyzed during the environmental and permitting process.

2.20 Exception for Maximum Dwelling Units on Urban Subcollectors

Proposed subcollectors serving new urban area developments with an average density of seven to eight dwelling units per acre and that meet the access requirements of Section 2.20 may serve up to 250 dwelling units, if approved by the Development Engineer. In this situation, the curbing shall be vertical. Prior to approval, the applicant must submit a traffic circulation study demonstrating a balanced traffic flow of less than 1500 vehicles per day past any access point. Street trees shall be mandatory along subcollectors serving higher densities of seven to eight dwelling units per acre and shall be in conformance with Section 5.03.

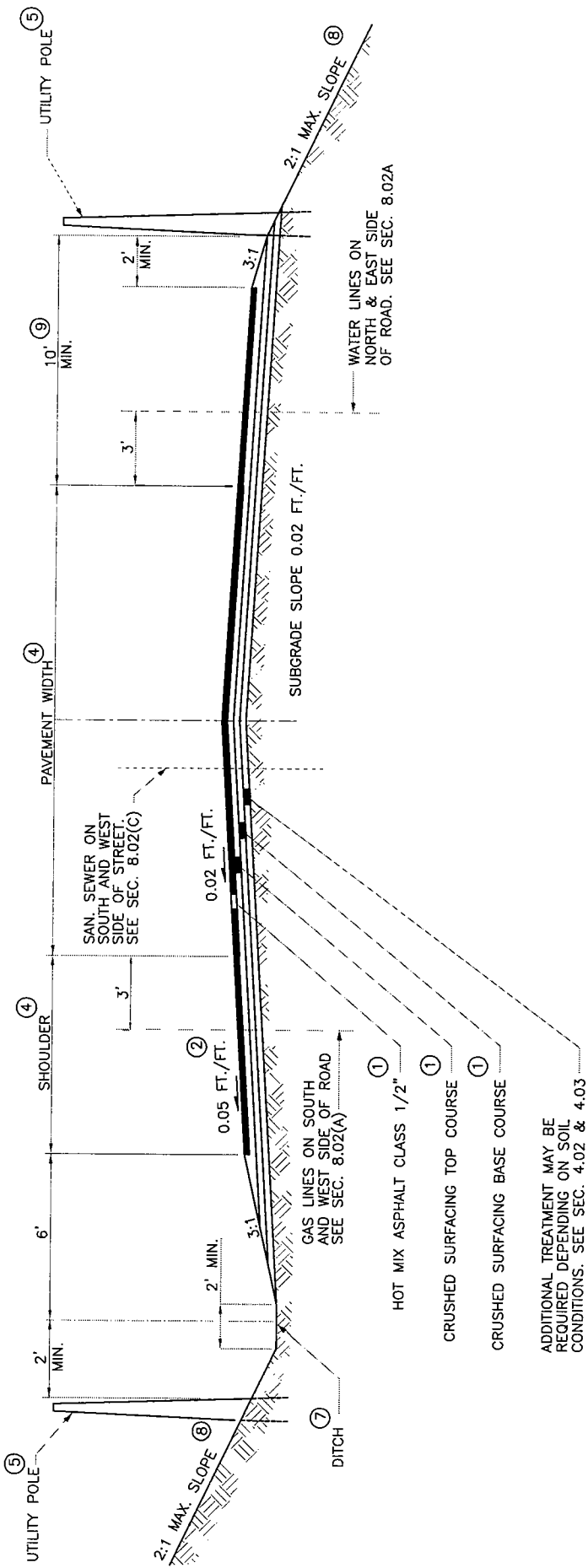

NOTES:

- ① THIS DRAWING ILLUSTRATES A TYPICAL ASPHALT CONCRETE ROAD SECTION, ACTUAL SURFACING FOR ARTERIALS AND COMMERCIAL ACCESS STREETS SHALL BE BASED ON SOILS AND TRAFFIC ANALYSIS PER SEC. 4.03. DESIGN FOR RESIDENTIAL ACCESS STREETS SHALL BE IN ACCORDANCE WITH SECS. 4.01 AND 4.02.
- ② SHOULDERS SHALL BE SURFACED AS REQUIRED BY SECS. 3.07 AND 4.01. SHOULDER SLOPE SHALL MATCH CROWN SLOPE OR 0.02 FT./FT. IF PAVED.
- 3. GRADES:
MINIMUM 0.5%
MAXIMUM SEE SECS. 2.02 AND 2.11.
- ④ FOR WIDTHS OF PAVEMENT, SHOULDER, AND RIGHT-OF-WAY, SEE SEC. 2.02.
- ⑤ FOR CLEARANCE OF UTILITY POLES SEE SEC. 8.02G AND FIG. 5-001.
- 6. SEE SEC. 3.08 FOR SEPARATED WALKWAY IF REQUIRED.
- ⑦ DITCH SECTIONS AND/OR LOCATIONS MAY VARY TO MEET REQUIREMENTS OF THE SURFACE WATER DESIGN MANUAL.
- ⑧ SEE SEC. 5.02 FOR SIDE SLOPE REQUIREMENTS.
- 9. PAVED SHOULDERS ARE REQUIRED FOR NEIGHBORHOOD COLLECTORS AND ARTERIALS SEC. 3.07(B).
- 10. SEE FIG. 3-015 THROUGH 3-018 WHEN AN EQUESTRIAN TRAIL IS REQUIRED.

VERTICAL CURB TYPE ROADWAY

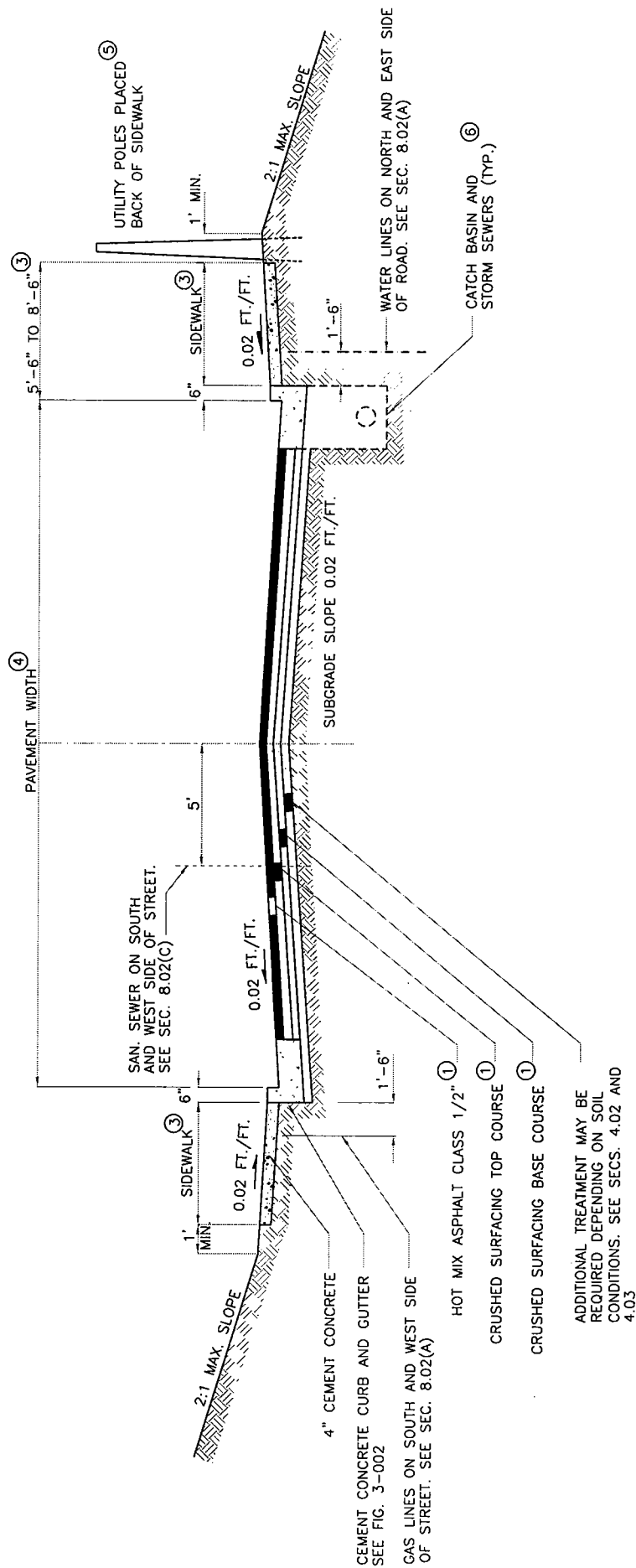

NOTES:

- ① THIS DRAWING ILLUSTRATES A TYPICAL ASPHALT CONCRETE ROAD SECTION, OPTIONAL DESIGN SECTION. ACTUAL SURFACING DESIGN FOR ARTERIALS AND COMMERCIAL ACCESS STREETS SHALL BE BASED ON SOILS AND TRAFFIC ANALYSIS PER SEC. 4.05. DESIGN FOR RESIDENTIAL ACCESS SHALL BE IN ACCORDANCE WITH SECS. 4.01, 4.04.
2. GRADES:
MINIMUM 0.5%
MAXIMUM SEE SECS. 2.03 AND 2.11.
- ③ SIDEWALKS SHALL BE 8 FT. WIDE IN BUSINESS DISTRICTS AND 6.5 FT. WIDE ON ARTERIALS IF NEXT TO TRAFFIC LANE, 5 FT. WIDE IF NEXT TO PARKING OR BIKE LANE, OR BEHIND PLANTING STRIP SEE SECTION 3.02.
- ④ SEE SECS. 2.02 AND 2.03. FOR WIDTHS OF PAVEMENT, SHOULDER, AND RIGHT-OF-WAY.
- ⑤ SEE SEC. 8.02G AND FIG. 5-001 FOR CLEARANCE OF UTILITY POLES.
- ⑥ SEE CHAPTER 7 FOR CATCH BASIN AND STORM SEWER LOCATIONS.
7. SEE SEC. 5.02 FOR SIDE SLOPE REQUIREMENTS.

ADDITIONAL TREATMENT MAY BE REQUIRED DEPENDING ON SOIL CONDITIONS. SEE SECS. 4.02 AND 4.03

ROLLED CURB TYPE ROADWAY

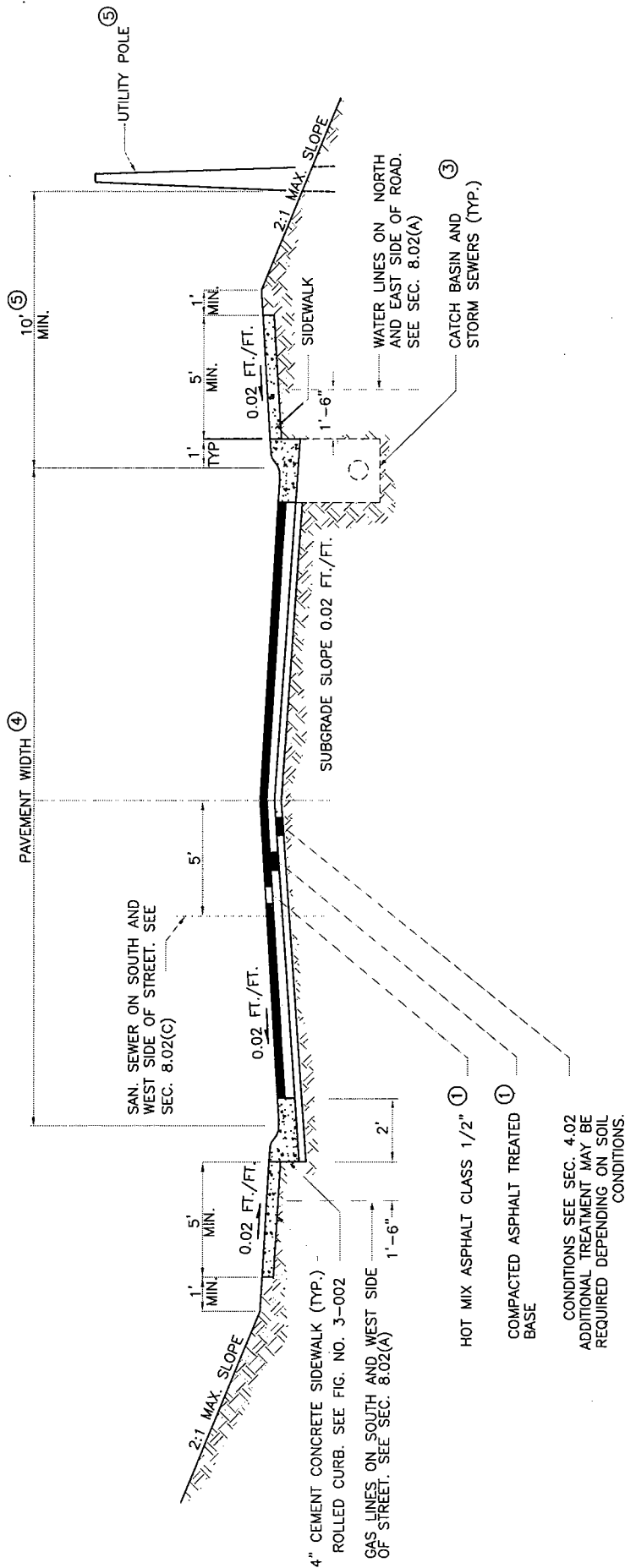

NOTES:

- 1 THIS DRAWING ILLUSTRATES A TYPICAL ASPHALT CONCRETE ROAD SECTION, OPTIONAL DESIGN SECTION. SEE SECS. 4.01, 4.04 AND 4.05. FOR OTHER ALTERNATIVES AND POSSIBLE REQUIREMENTS FOR FRACTURED AGGREGATE OR INCREASED THICKNESS OF SURFACING MATERIALS.
2. GRADES:
 MINIMUM 0.5%
 MAXIMUM SEE SECS. 2.03 AND 2.11.
- 3 SEE CHAPTER 7 FOR CATCH BASIN AND STORM SEWER LOCATIONS. SEE FIGS. 7-017, 7-019, 7-020, AND 7-021 FOR GRATE DETAILS.
4. SEE SECS. 2.03 FOR WIDTHS OF PAVEMENT AND RIGHT-OF-WAY.
- 5 SEE SEC. 8.02G AND FIG. 5-001 FOR CLEARANCE OF UTILITY POLES.
6. SEE SEC. 5.02 FOR SIDE SLOPE REQUIREMENTS.
7. A PAVEMENT WIDTH OF 20 FT. IS ALLOWED FOR URBAN 4-LOT SHORT PLATS. THE REVIEWING AGENCY SHALL DETERMINE ANY NEED FOR SIDEWALKS.

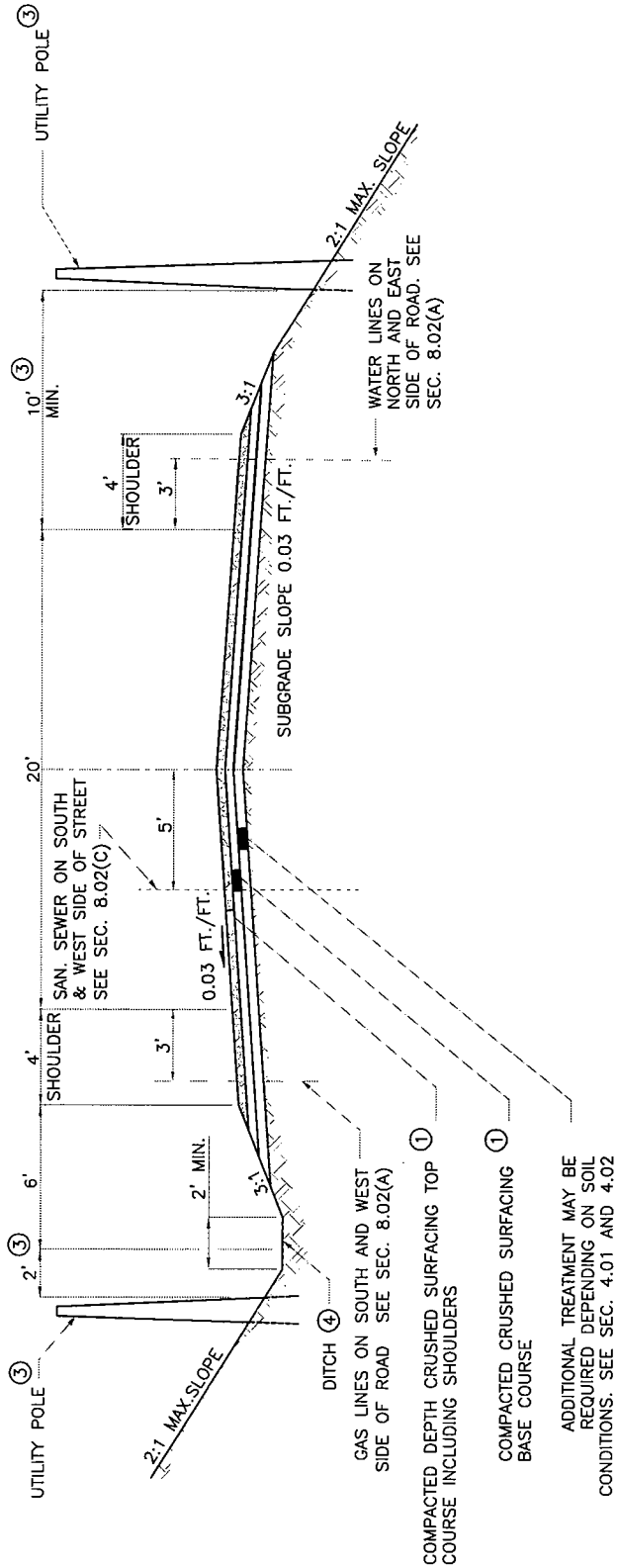

NOTES:

- ① GRAVEL SURFACING IS ACCEPTABLE ONLY ON RURAL MINOR ACCESS STREETS (RESIDENTIAL) WHICH ARE PRIVATE STREETS AND PRIVATE ROADWAYS WITHIN DESIGNATED AGRICULTURAL DISTRICTS. SEE SECS. 2.03 & 2.17.
2. GRADES:
MINIMUM 0.5%
MAXIMUM SEE SECS. 2.02 & 2.11.
- ③ FOR CLEARANCE OF UTILITY POLES SEE SEC. 8.02G & FIG. 5-001.
- ④ DITCH SECTIONS AND/OR LOCATIONS MAY VARY TO MEET REQUIREMENTS OF SURFACE WATER DESIGN MANUAL.
5. SEE SEC. 5.02 FOR SIDE SLOPE REQUIREMENTS.
6. ANY GRAVEL ROADS USED FOR FORESTRY PURPOSES MUST CONFORM TO RCW 76.09, FOREST PRACTICES ACT, WHICH MAY EXCEED STANDARDS IN SURFACE WATER DESIGN MANUAL.
7. THE SHOULDERS MAY BE REDUCED TO 2 FT. FOR RURAL MINOR ACCESS STREETS. SEE SEC. 2.02(C)
8. A PAVEMENT WIDTH OF 20 FT. IS REQUIRED FOR RURAL RESIDENTIAL 4-LOT SHORT PLATS.

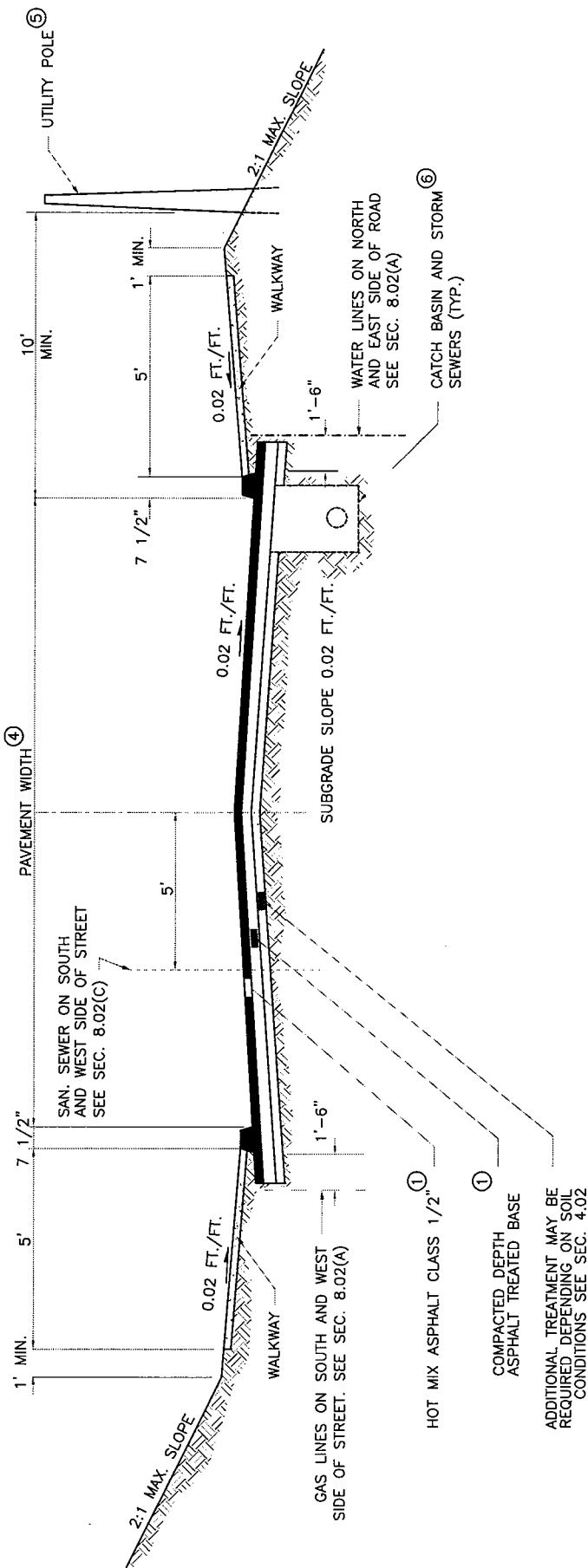

NOTES:

- ① THIS DRAWING ILLUSTRATES A TYPICAL ASPHALT CONCRETE ROAD SECTION, OPTIONAL DESIGN SECTION. SEE SECS. 4.01, 4.04 AND 4.05 FOR OTHER ALTERNATIVES AND POSSIBLE REQUIREMENTS FOR FRACTURED AGGREGATE OR INCREASED THICKNESS OF SURFACING MATERIALS.
- ② SEE FIG. 3-002 FOR EXTRUDED CURB DETAIL
3. GRADES:
 MINIMUM 0.5%
 MAXIMUM SEE SECS. 2.02 AND 2.09.
- ④ SEE SECS. 2.02 FOR WIDTHS OF PAVEMENT AND RIGHT-OF-WAY
- ⑤ SEE SEC. 8.02(G) AND FIG. 5-001 FOR CLEARANCE OF UTILITY POLES
- ⑥ SEE CHAPTER 7 FOR CATCH BASIN AND STORM DRAIN LOCATIONS.
7. WALKWAY SHALL BE CRUSHED SURFACING, ALTERNATIVE V, OR AS REQUIRED BY THE REVIEWING AGENCY.
8. SEE SEC. 5.02 FOR SIDE SLOPE REQUIREMENTS.

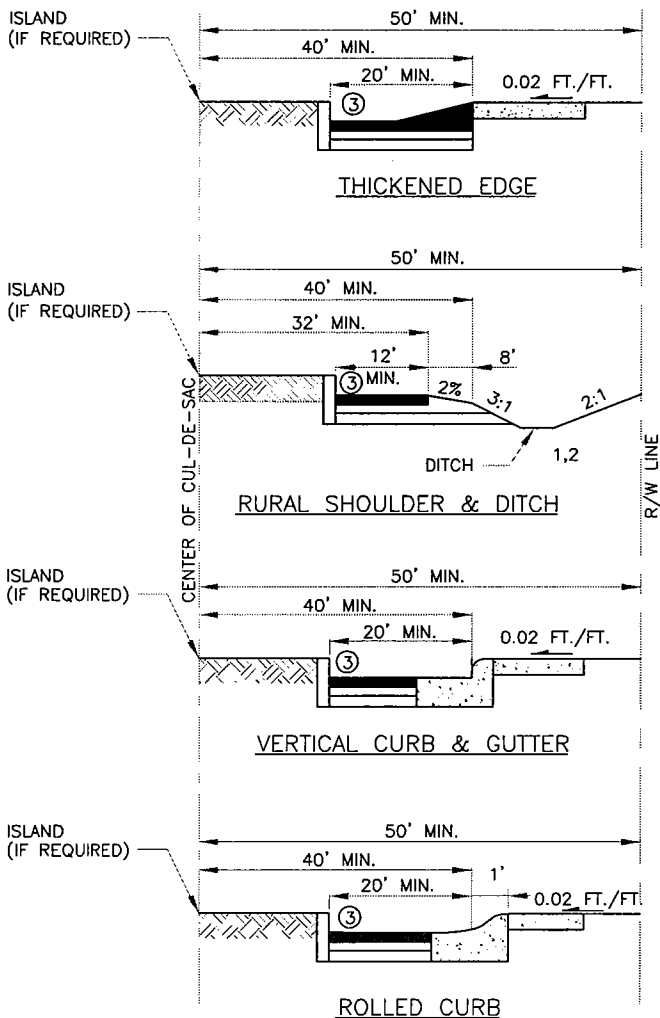
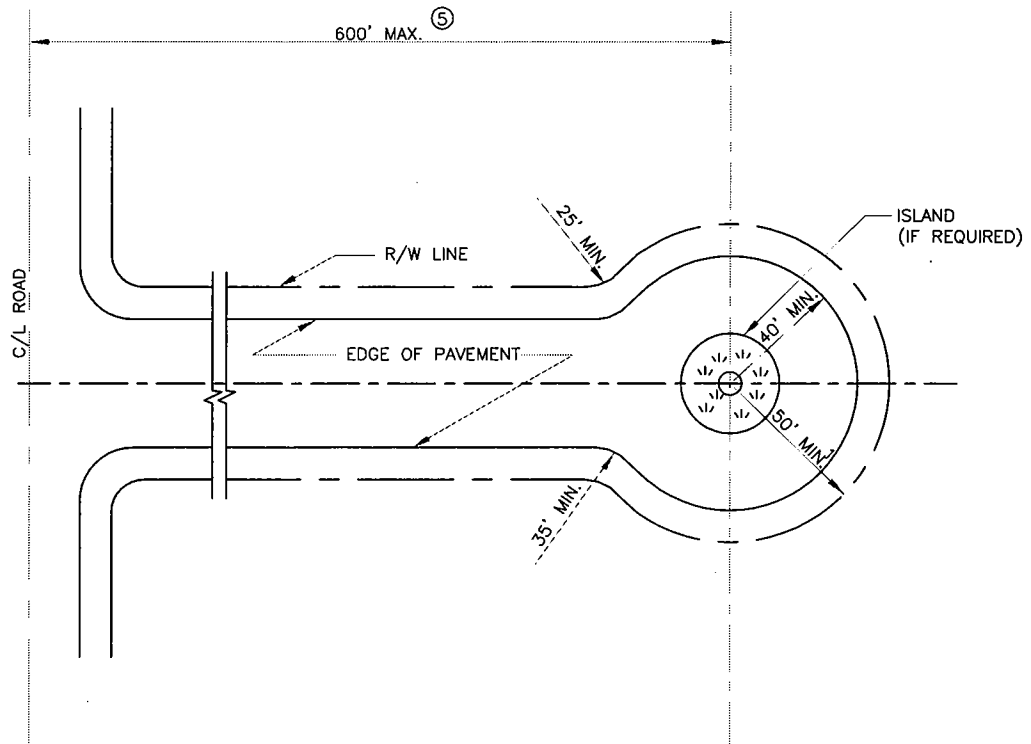

NOTES:

1. SEE SEC. 2.08.
2. EXTRUDED CURB IS ALSO ACCEPTABLE FOR OUTER EDGE AS ALTERNATIVE TO SHOULDER AND DITCH. SEE FIG. 2-005.
- ③ ISLAND AT CENTER OF BULB SHALL HAVE VERTICAL OR EXTRUDED CURB. SEE FIG. NO. 3-002.
4. ISLAND IS MANDATORY WHEN RADIUS OF PAVED AREA EXCEEDS 40 FT.
- ⑤ SEE SEC 2.08 FOR CUL-DE-SAC LENGTH EXCEPTION.
6. SEE SECS. 2.03 AND 2.08 FOR RIGHT-OF-WAY REDUCTION REQUIREMENTS.

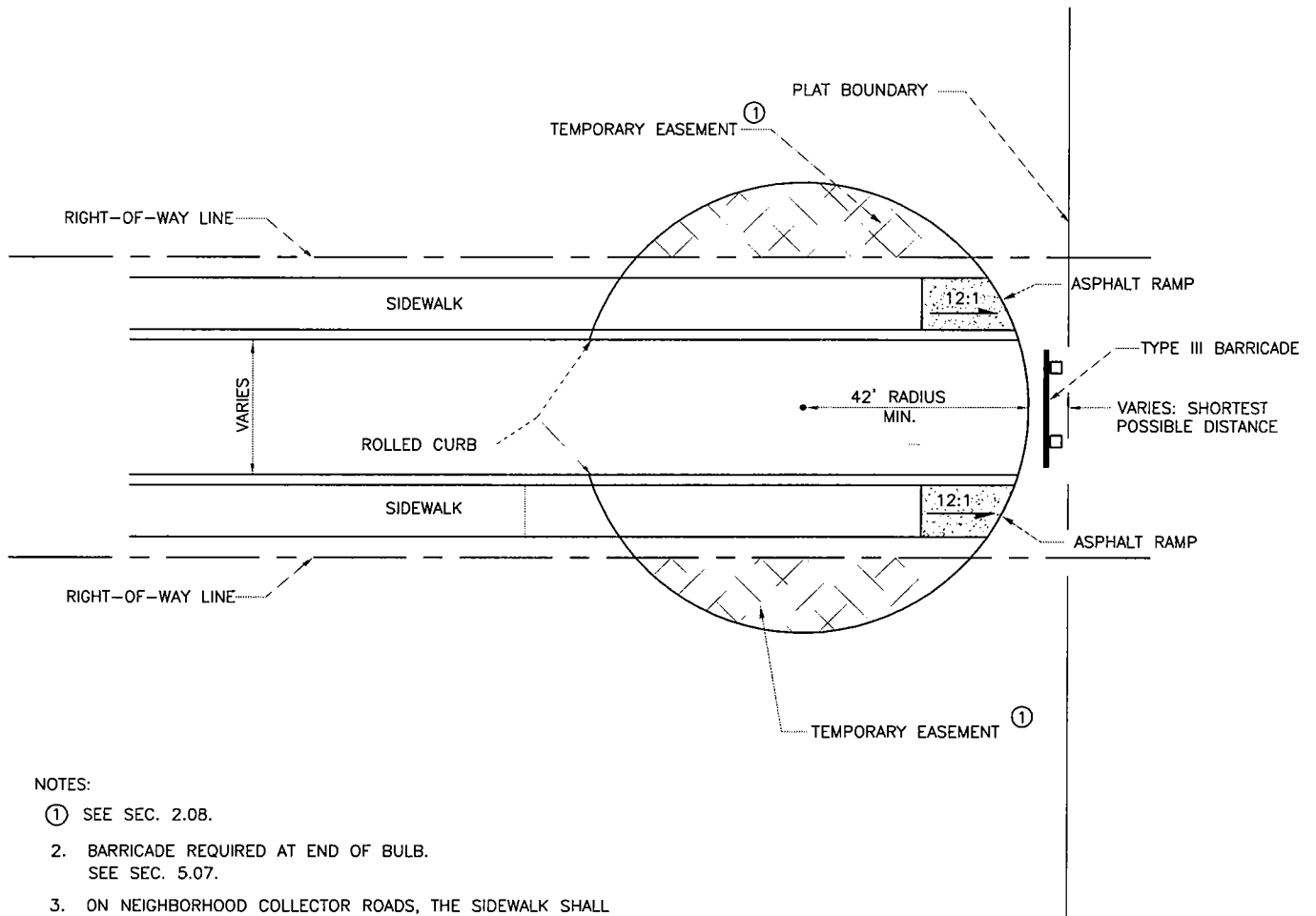

NOTES:

- ① SEE SEC. 2.08.
- 2. BARRICADE REQUIRED AT END OF BULB.
SEE SEC. 5.07.
- 3. ON NEIGHBORHOOD COLLECTOR ROADS, THE SIDEWALK SHALL
NOT BE EXTENDED THRU THE TEMPORARY CUL-DE-SAC.

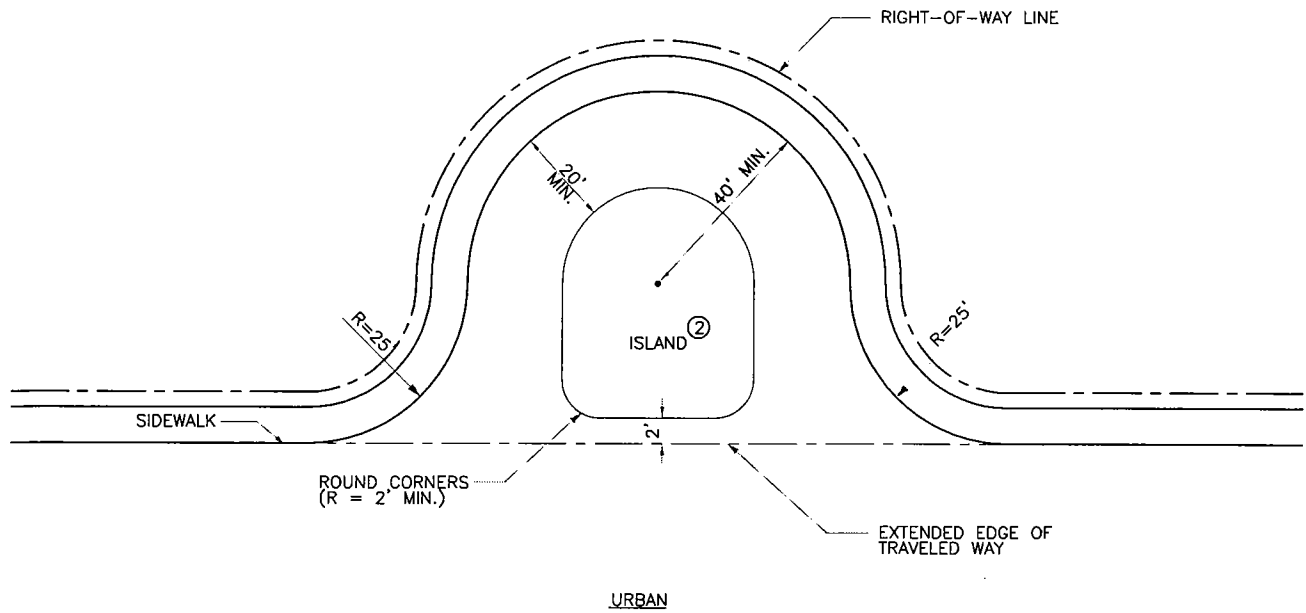

NOTES:

1. SEE SEC. 2.08(F)
- ② ISLAND REQUIRED ON EYEBROWS WITH RADIUS GREATER THAN 25 FEET.
3. MIN. ISLAND DIAM. SHALL BE 10 FEET.
4. ISLAND SHALL HAVE VERTICAL OR EXTRUDED CURB. SEE FIG. 3-002

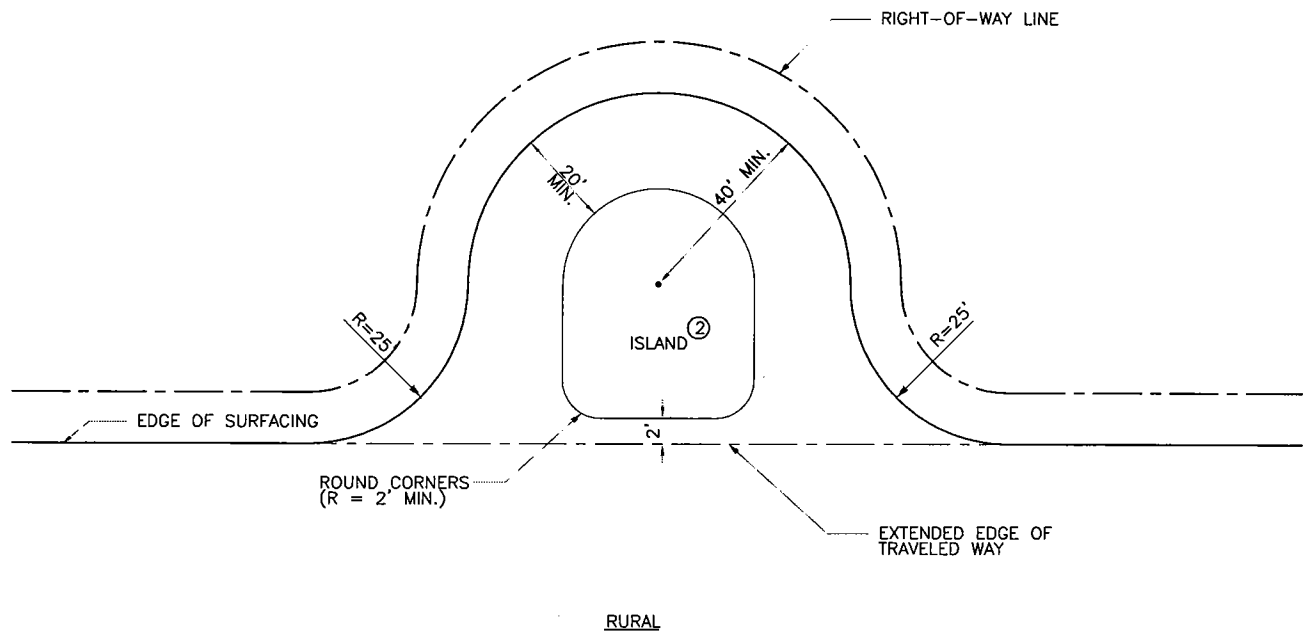

NOTES:

1. SEE SEC. 2.08(F)
- ② ISLAND REQUIRED ON EYEBROWS WITH RADIUS GREATER THAN 25 FEET.
3. MIN. ISLAND DIAM. SHALL BE 10 FEET.
4. ISLAND SHALL HAVE VERTICAL OR EXTRUDED CURB. SEE FIG. 3-002

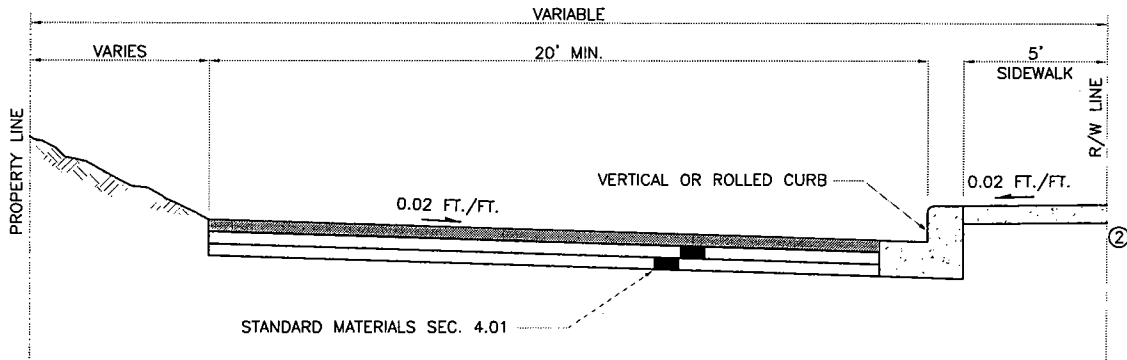

URBAN

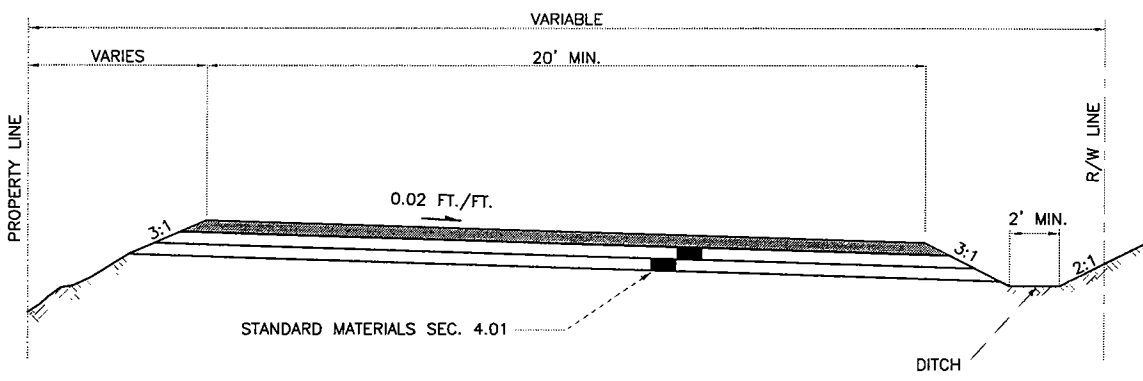

RURAL

- NOTE:
1. SEE SEC. 2.07 FOR HALF-STREET REQUIREMENTS.
 2. SEE SEC. 3.02 FOR CONCRETE SIDEWALK REQUIREMENTS.
 3. EDGE OF PAVEMENT TO BE CONSTRUCTED AS SHOWN FOR CUT OR FILL SECTION AS APPROPRIATE.

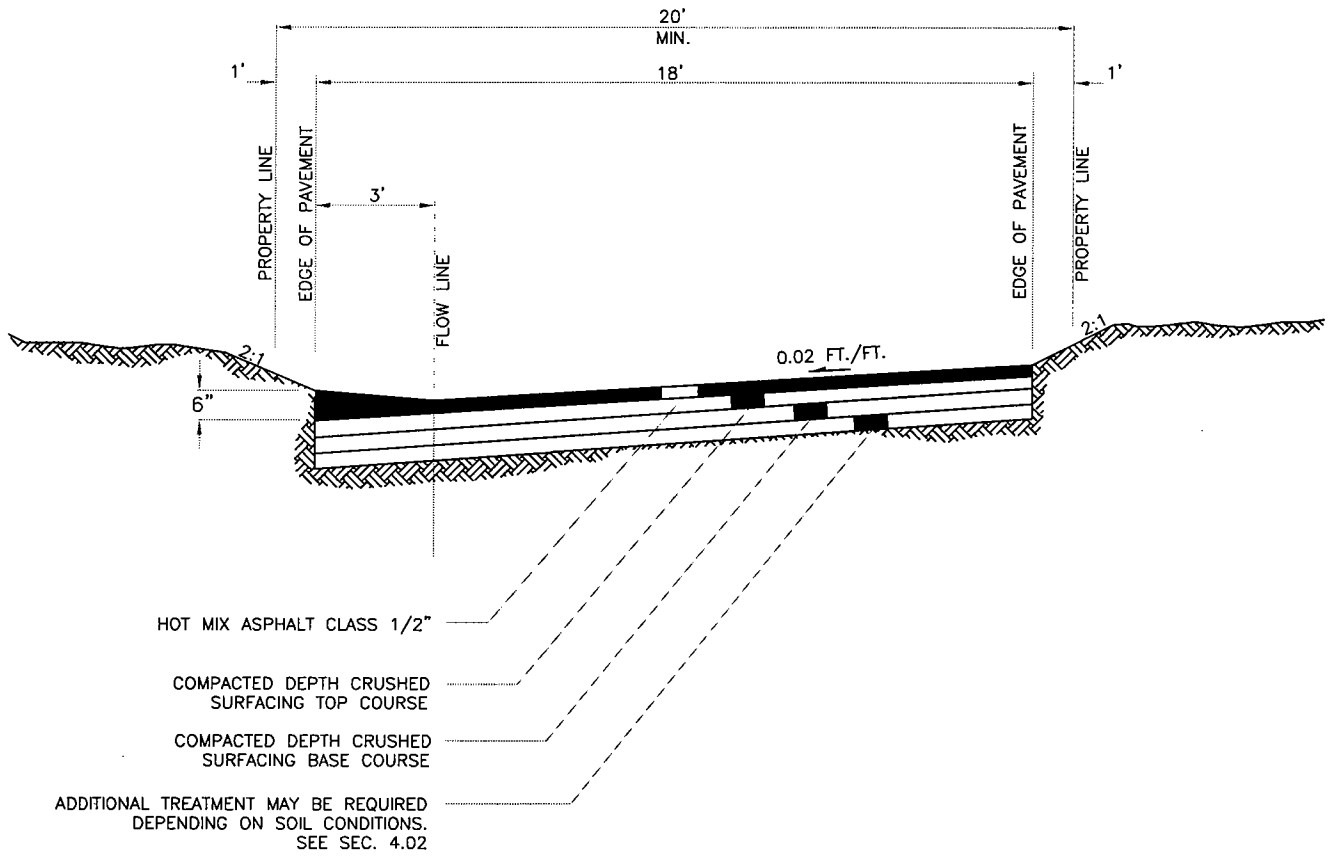

NOTE:

1. SEE SEC. 2.09 FOR ALLEY REQUIREMENTS.

ALLEY PAVEMENT DETAIL

FIG. 2-010

2-34

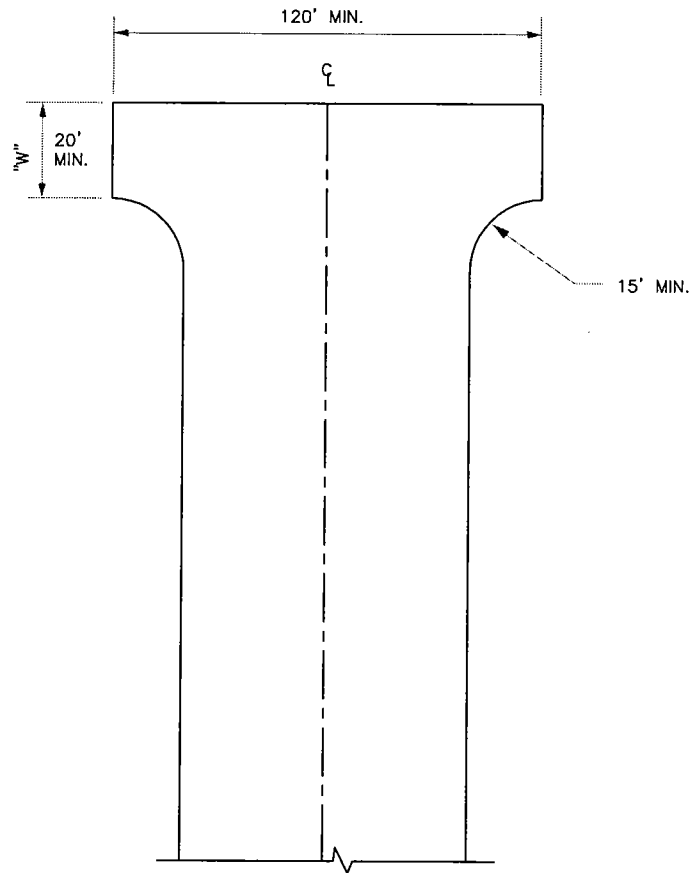

HAMMERHEAD

NOTES:

1. 50 FT. MIN. RIGHT-OF-WAY RADIUS. SIDEWALKS AND UTILITIES MAY BE LOCATED WITHIN EASEMENTS.
2. ALTERNATIVE DESIGNS BY APPROVAL OF THE COUNTY ROAD ENGINEER AND FIRE MARSHAL.

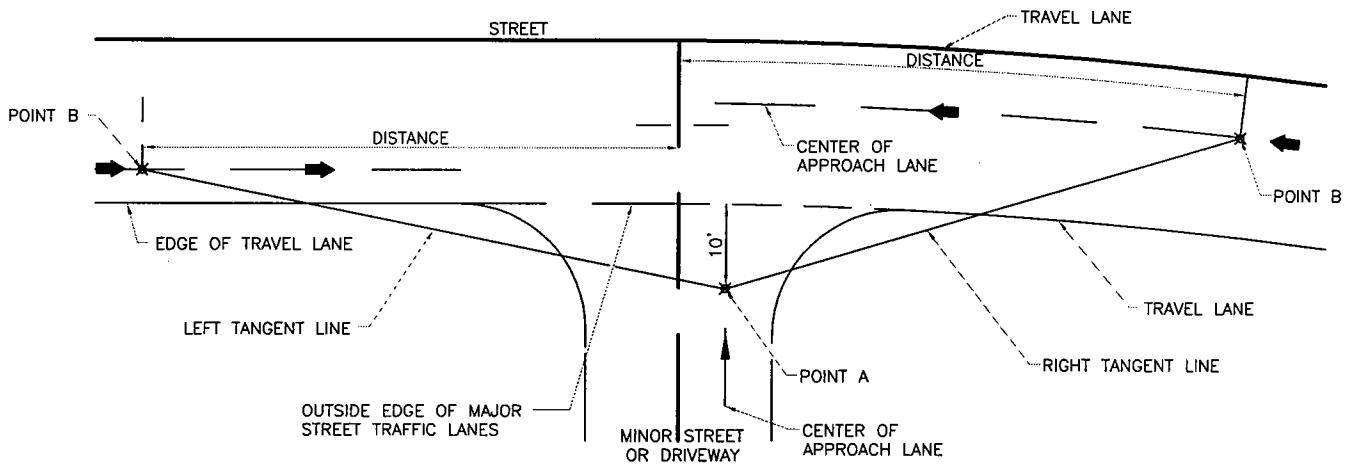

NOTES:

1. PARKING STRIPS OR LANES DESIGNATED FOR PARKING ONLY ARE OUTSIDE THIS REFERENCE LINE AND ARE NOT INCLUDED IN THE MAJOR STREET TRAFFIC LANES.
2. SEE STOPPING SIGHT DISTANCE SEC. 2.12
3. SEE INTERSECTIONS, SEC 2.10(D)
4. SEE ENTERING SIGHT DISTANCE, SEC. 2.13

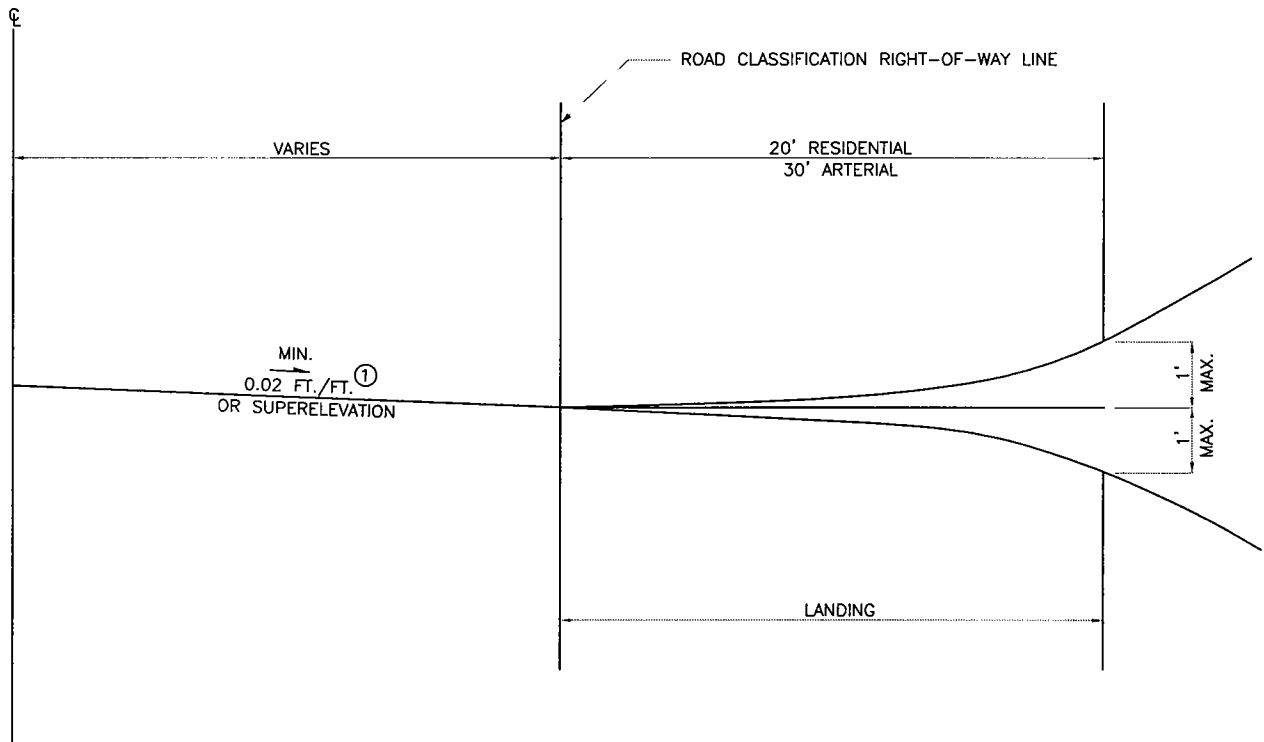

NOTES:

- ① SEE SECS. 2.02 AND 2.03 FOR SUPERELEVATION REQUIREMENTS.
- 2. SEE SEC. 2.10 FOR LANDING REQUIREMENTS.

CHAPTER 3. DRIVEWAYS, SIDEWALKS, BIKEWAYS, TRAILS

3.01 Driveways

This section provides driveway standards for connections to public and private roads. It is not the intent of these Standards to govern design or location of driveways on private property except where they connect to a roadway. However, fire access requirements governed by the Uniform Fire Code, and Zoning Code (KCC21A), establish criteria for driveway widths. No new driveway connection shall be constructed which does not conform to this chapter and minimum sight distance criteria established in 2.12 and 2.13.

A. Dimensions, slope, and detail shall be as indicated in Figures 3-003, 3-004, 3-012, 3-013, and 3-014, as further specified in the following subsections. See Section 2.14 for entering sight distance and 2.12 for stopping sight distance requirements.

B. New Driveways Requirements:

1. Driveways directly giving access on to arterials may be denied if alternate access is available.
2. All abandoned driveway areas on the same frontage shall be removed, and the curbing and sidewalk or shoulder and ditch section shall be properly restored.
3. Maintenance of driveway approaches shall be the responsibility of the owner whose property they serve.
4. Driveways shall be paved with asphalt between the edge of the paved surface and the right-of-way line, except when on curb and gutter section roadways. See Figure 3-003.
5. For driveways crossing an open ditch section, culverts shall be adequately sized to carry anticipated storm water flows and in no case be less than 12 inches) in diameter, and at a minimum the culvert shall be equal to or larger than existing pipes within 500 feet upstream. Pipe should be long enough to allow for the minimum 3:1 beveled ends, figure 7-001. The property owner making the installation shall be responsible for determining proper pipe size. The Development Engineer may require the owner to verify the adequacy of pipe size.
6. Storm drainage from driveway surfaces must be accounted for in the roadway drainage design. Direct discharge to roadway surfaces and sidewalks are not allowed.

C. Location and Width of New Driveways. Refer to Figure 3-004.

1. A residential driveway shall typically serve only one parcel except as noted below. The minimum width of a residential driveway is 10-feet and the maximum width is 30 feet. A driveway serving more than one parcel

shall be classed as a joint use driveway, commercial driveway, or a private street, except as provided in 3.a. below.

2. On frontages 75 feet or less, no more than one driveway per lot shall be constructed. On frontages over 75 feet, the Development Engineer may permit two or more driveways per lot, subject to approval.
3. No portion of driveway width shall be allowed within 5 feet of side property lines where it intersects with street right-of-way line in residential areas or 9 feet in commercial areas except as follows:
 - a. A joint-use driveway tract may be used to serve two parcels:
 - i. Minimum driveway tract width in urban areas shall be 20 feet with an 18-foot paved surface cross slope in one direction and curb or thickened edge on one side. Minimum driveway length shall be 20 feet from right-of-way line. When required, radius returns on paved apron shall have 10-foot radii.
 - ii. Minimum driveway tract width in rural areas shall be 20 feet; 30 feet if a ditch is required. Minimum driveway length shall be 20 feet from right-of-way line. Radius returns on paved apron shall have 10-foot radii.
 - iii. Driving surface (rural areas) shall be 18 feet, paved or gravel, with a paved apron from the edge of pavement of intersecting street to right-of-way line or 20 feet, whichever is greater.
 - iv. The Development Engineer may allow use of an easement if the only access to a serving roadway is through an adjacent parcel not owned by the applicant, or for urban residential short plats to satisfy minimum lot width requirements.
 - b. Driveways may utilize full width of narrow "pipe-stem" parcels or easements if approved by Development Engineer.
 - c. On cul-de-sac bulbs, eyebrows, or hammerheads as necessary for proposed residential access.
4. Grade transitions, excluding the tie to the roadway, shall be constructed as smooth vertical curves. Ties to the roadway shall be constructed as shown in driveway figures 3-003, 3-004, 3-005, 3-012, 3-013, and/or 3-014. The maximum change in driveway grade, within the right-of-way, shall be 8 percent within any 10 feet of distance on a crest and 12 percent within any 10 feet of distance in a sag vertical curve. Whenever there is a potential for future roadway widening, the driveway shall be graded to match the future widened road section without encroachment into graded shoulder or sidewalk. The design engineer for proposed developments shall consider the access driveway profile when designing the serving road to ensure that required grade transitions can be complied with considering building set back and lot terrain conditions. Driveways with slope exceeding 2 percent

shall be designed to ensure surface water does not impact the right-of-way adjacent to the driveway.

5. Driveways in rolled curb sections may be constructed abutting and flush with sidewalk or back of curb without gapping or lowering height of curb.
- D. Existing driveways may be reconstructed at their existing location provided such reconstruction is compatible with the adjacent road. For new development and/or changes in land use, existing driveway connections, which do not conform to this chapter, shall be reconstructed to the requirements for new driveways.
- E. The minimum width for a commercial/business district driveway is 25 feet, and the maximum width is 35-feet.
- F. For commercial or industrial driveways with heavy traffic volumes or significant numbers of trucks, the Development Engineer may require construction of the access as a road intersection. This requirement will be based on traffic engineering analysis submitted by the applicant that considers, among other factors, intersection spacing, sight distance, and traffic volumes.
- G. Notwithstanding any other provisions, driveways will not be allowed where they are prohibited by separate County Council action or where they are determined by the County Road Engineer or Development Engineer to create a hazard or impede the safe operation of traffic on the roadway.

3.02 Concrete Sidewalks

Sidewalks shall be required and constructed on urban category, curb and gutter type streets, figures 2-003 and 2-004, unless otherwise allowed by these Standards or the County Road Engineer. They shall be located and constructed as follows:

1. On all arterials, neighborhood collectors, subcollectors, subaccess, attached dwelling, business access streets, and industrial access streets both sides.
2. On minor access streets (commercial), both sides unless alternative routes are provided for pedestrians.
3. On minor access streets (residential) exceeding 150 feet, both sides.
4. On any cul-de-sacs, both sides.
5. Extended off-street walkways may be required by the Development Engineer to provide direct connections for ease and safety of pedestrians.
6. Sidewalks shall be constructed next to the curb except in those situations where the County Road Engineer approves the construction of a planting strip adjacent to the curb.
7. Sidewalks shall be a minimum width of 5 feet on residential access streets and arterials. Minimum sidewalk width shall be six and one-half feet on

arterials if curb is next to traveled lane. Sidewalks shall be a minimum width of eight feet on commercial access streets.

8. At least 8 feet wide:
 - a. In business/commercial districts where most of the store frontage is within 80 feet of the street right-of-way.
 - b. Within the curb radius returns of all arterial intersections where curb ramps are required.
 - c. Within designated bus zones to provide a landing area for wheelchair access to transit services.
9. With specified width greater than 8 feet where the County Road Engineer or Development Engineer determines this is warranted by expected pedestrian traffic volume.
10. With Portland cement concrete surfacing as provided in Sections 3.03 and 4.01. See specifications for joints in Section 3.04 and figure 3-001.

3.03 Construction of Curbs, Gutters, and Sidewalks

- A. Subgrade compaction for curbs, gutters, and sidewalks shall meet a minimum 95 percent of maximum density.
- B. Concrete for curbs, gutters, and sidewalks shall be Class 4000, furnished and placed in accordance with WSDOT/APWA Standard Specifications, Sections 6-02, 8-04, and 8-14. Cold weather precautions as set forth in WSDOT/APWA Standard Specifications Sections 5-05.3(14) and 6-02.3(6) A shall apply. Once concrete is placed it shall be troweled smooth with a steel trowel. Before jointing or edging, the surface of the walk shall be lightly brushed in a transverse direction with a soft brush. Concrete sidewalks shall be cured for at least 72 hours. Curing shall be by means of moist burlap or quilted blankets or other approved methods. During this curing period, all traffic, both pedestrian and vehicular, shall be excluded.
- C. Extruded cement concrete curb shall be anchored to existing pavement by either steel tie bars or adhesive in conformance with WSDOT/APWA Standard Specification Section 8-04. Joints shall be spaced at ten (10) foot intervals and in accordance with figure 3-001.
- D. Extruded asphalt curbs shall be anchored by means of a tack coat of asphalt in accordance with WSDOT/APWA Standard Specification Section 8-04.
- E. Transitions between curb streets or curbs with sidewalks to rural road sections shall meet the following:
 1. At intersections, curb wraps shall extend around the radius to better define the lane edge and enhance safe turning movements. The appropriate access ramp described in Section 3.06 shall be provided at terminus.
 2. For straight connections, end section shall conform to figure 3-009.

3.04 Expansion and Dummy Joints.

- A. An expansion joint consisting of 3/8" inch or 1/4 inch \times full depth of pre-molded joint material shall be placed around fire hydrants, poles, posts, and utility castings and along walls or structures in paved areas. Joint material shall conform to the requirements of ASTM D994 (AASHTO M33). See figure 3-001.
- B. A expansion joint consisting of 3/8 inch or 1/4 inch \times 2 inch of pre-molded joint material shall be placed in curbs and sidewalks at 10 foot intervals and at sides of drainage inlets. When curbs and/or sidewalks are placed by slip-forming, a pre-molded strip up to 1/2 inch thick and up to full depth may be used.
- C. Expansion joints in sidewalk shall be located so as to match the joints in the curb whether sidewalk is adjacent to curb or separated by planting strip.
- D. Tool marks consisting of 1 inch V-grooves must be made in sidewalk at five-foot intervals, intermediate to the expansion joints.
- E. As an alternative to expansion joints around structures, reinforcing bars may be embedded in concrete on four sides of structures.
- F. Interface between curb and adjacent sidewalk on integral pour construction shall be formed with 1- inch radius edging tool. On separate pour construction an expansion joint consisting of 3/8 inch or 1/4 inch \times full depth of pre-molded joint material shall be placed between the curb or thickened edge and the adjacent sidewalk.

3.05 Curb Ramps

On all curbed streets, ramped sections to facilitate passage of disabled persons shall be constructed through curb and sidewalk at street intersections and other crosswalk locations, figure 3-006. Where a ramp is constructed on one side of the street, a ramp shall also be provided on the opposite side of the street. Two ramps shall be provided per radii on arterials.

Curb ramps shall be positioned so that a ramp opening is situated within the marked crosswalk or crossing area if unmarked, figure 3-008. The ramps shall have detectable warnings consisting of raised truncated domes with a minimum diameter of 0.9 inches and a height of 0.2 inches and center-to-center spacing of a minimum 2.35 inches and are required to have contrasting surfaces (light to dark or dark to light), which is an integral part of the surface, figure 3-007.

The following requirements must also be met:

1. A minimum 4-foot landing shall be provided.
2. Placement of gratings, storm drains, utility and sewer access covers and similar fixtures on ramps, landings, transitions and portions of the gutter within the pedestrian access route are prohibited.

3. Grade breaks on ramp runs, blended transitions, landings, and gutter areas within the pedestrian access route are prohibited.
4. Provide a flush transition of permitted grade breaks such as at the top and bottom of the ramp run.
5. Vertical changes on curb ramps, landings, and gutter areas within the pedestrian access route are prohibited.

3.06 Concrete Steps, Metal Handrail and Barrier-Free Access Ramps

- A. Steps shall only be used where acceptable alternative access is available for barrier-free access, and there is a need for a separate stairway. Where used, concrete steps shall be approved by the County Road Engineer and constructed in accordance with figure 5-007 or other design acceptable to the County Road Engineer or Development Engineer and consistent with the WSDOT/APWA Standard Specifications. Handrails, whether for steps or other applications, shall be provided consistent with Figure 5-007 and the WSDOT/APWA Standard Specifications.
- B. Ramps used to provide barrier-free access shall have a maximum slope of 12:1 with a maximum rise of 30 inches between landings. Landings shall have a minimum length of 4-feet and should be of sufficient width to allow wheelchairs to pass, generally 4-foot minimum width for two-way traffic.

3.07 Asphalt Shoulders

- A. In urban areas, asphalt paved shoulders may be used where approved by the County Road Engineer on existing roads to provide for bicycle and pedestrian use. When allowed, paved shoulders shall be placed in conformance with Sections 2.02.
- B. In rural areas, asphalt paved shoulders, which may serve as walkways and bikeways shall be provided on both sides of any arterials and neighborhood collectors or other roads designated in the King County Nonmotorized Transportation Plan or as directed by the County Road Engineer or Development Engineer.
- C. Where shoulders are paved on one side only, they shall be delineated by a four-inch white thermoplastic edge line.

3.08 Separated Pedestrian Walkways and Trails

Separated pedestrian walkways and trails shall be provided where designated in the King County Comprehensive Plan or where required by the County Road Engineer or Development Engineer because of anticipated significant public usage.

Separated facilities are typically located on an easement or within the right-of-way when separated from the roadway by a drainage ditch or barrier. Where multi-purpose trails intersect with motorized traffic, sight distance, marking and signalization (if warranted) shall be as provided in MUTCD.

Separated asphalt walkways are designed primarily for pedestrians and are typically located within the right-of-way or easement. Minimum width shall be 5 feet with asphalt surfacing as indicated in Section 4.01D.

3.09 School Access

When school access is required as part of development approval, the surfacing shall be an asphalt walkway, concrete sidewalk or full-width delineated shoulder unless another alternative is available and approved by the County Road Engineer through a road variance request.

3.10 Bikeways

Every effort shall be made to include safe bikeways on all new roadways and reconstruction projects, unless bicyclists are prohibited by law from using the roadway. An exception may be granted also if the designers can demonstrate that there is no need for accommodation or the cost exceeds 20 percent of the project's construction cost. They shall be located and designed according to the Non-motorized Transportation Plan, King County Comprehensive Plan, Roads Capital Improvement Program, Transportation Needs Report or as directed by other County code or policy.

The planning and design of bikeways in any category shall be in accordance with the WSDOT Design Manual and the AASHTO Guide for the Development of Bicycle Facilities, current edition.

Bikeways are generally shared with other transportation modes. When substantial bike usage is expected, which would benefit from construction of a bikeway, the facility may be required to be designed exclusively for bicycle use. However, where there is limited right-of-way availability or environmental constraints the bikeway may be a shared roadway facility. Bikeways are categorized below based on degree of separation from motor vehicles and other transportation modes. This classification does not denote preference of one type over another.

The Standards classify bikeways into five groups:

1. **Shared Roadway:** A roadway that accommodates bicyclists without special markings or designations. Shared roadways accommodate bicycles by either providing a wide paved shoulder or a wide curb lane. A paved shoulder should be at least 4 feet wide to accommodate bicycle travel. A wide curb lane should have a total width of 14 feet without parking. A shared roadway using either a wide curb lane or shoulder is sufficient bicycle accommodation on most roads. See Figure 3-019.
2. **Signed Shared Roadway:** Shared roadways that are identified by signing as preferred bicycle routes.
3. **Bike Lanes:** A portion of the road that is designated by pavement striping for exclusive bicycle use. Bicycle lanes may be signed as part of a directional route system. Bicycle lanes are 5 feet wide on a curbed road and minimum of 4 feet wide as a shoulder bike lane. See figure 3-019.

4. Bike Path: Bicycle facilities on exclusive rights of way and with minimal cross flow by motor vehicles. However, they may be useful extensions of the road network in some situations, such as providing bicycle connections between roads in places where motor-vehicle travel is prohibited.
5. Shared Use Path: Shared use paved tread trails, double track, are typically designated for bicycle and pedestrian use and in general follow a right-of-way independent from any road. They shall be designed to meet the requirements of figure 3-016.
6. Striping and signing shall be implemented as follows:
 1. Pavement markings shall be used on bike lanes and paths according to MUTCD and AASHTO Guide for the Development of Bicycle Facilities, current edition.
 2. The design of all signalized intersections will address bicycle usage.

3.11 Equestrian Facilities

Every effort shall be made to include safe equestrian facilities on all new roadways and reconstruction projects located within designated equestrian communities, unless equestrians are prohibited by law from using the roadway. An exception may be granted also if the designers can demonstrate that there is no need for accommodation or the cost exceeds 20 percent of the project's construction cost.

Equestrian facilities shall meet the following requirements:

1. Shoulders adjacent to the traveled way intended for equestrian use shall be surfaced full-width, with a minimum width of 4 feet on local access streets and a minimum width of 8 feet on neighborhood collectors and arterials. The surfacing shall meet the rural shoulder specifications outlined in Table 4-1 of these Standards.
2. When a separated trail is required it shall be constructed with an 18 percent maximum grade, minimum 10-foot vertical clearance and 5-foot-wide pathway zone and meet the requirements of figure 3-015. The trail shall be constructed of native soil or, where drainage or erosion problems are present, a minimum of 2.5 inches of crushed surfacing top course on graded and compacted native soil shall be used. Native soil, which is not free draining, shall be removed and replaced with free draining soil as necessary to provide a maintainable and well-drained subgrade. Additional crushed surfacing, cinders or other stabilizing materials shall be required if heavy usage is anticipated or if there is any evidence of instability in the subgrade, including free water, swamp conditions, fine-grained or organic soils, slides or uneven trails. When a multi-use trail is required, it shall meet the requirements of figures 3-016, 3-017 or 3-018.
3. Where the trail intersects with a paved roadway, the trail approach shall be paved from the edge of the traveled lane to the right-of-way line.

4. Appropriate signs shall be provided to indicate the location of street crossings for trails.
5. On roads with high volumes of equestrian traffic, the County Traffic Engineer may require a crossing signal where the trail and roadway intersects. The signals shall be designed in consultation with and approved by the County Traffic Engineer.

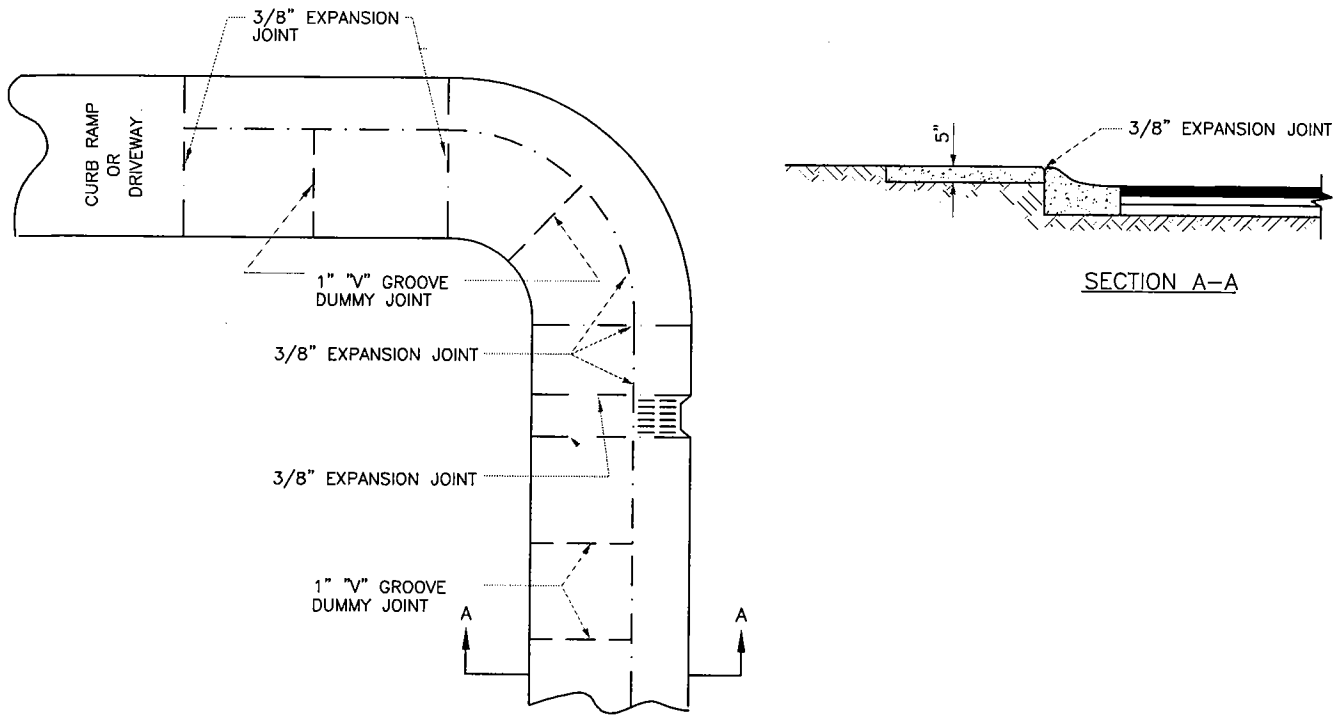

ROLLED CURB & SIDEWALK

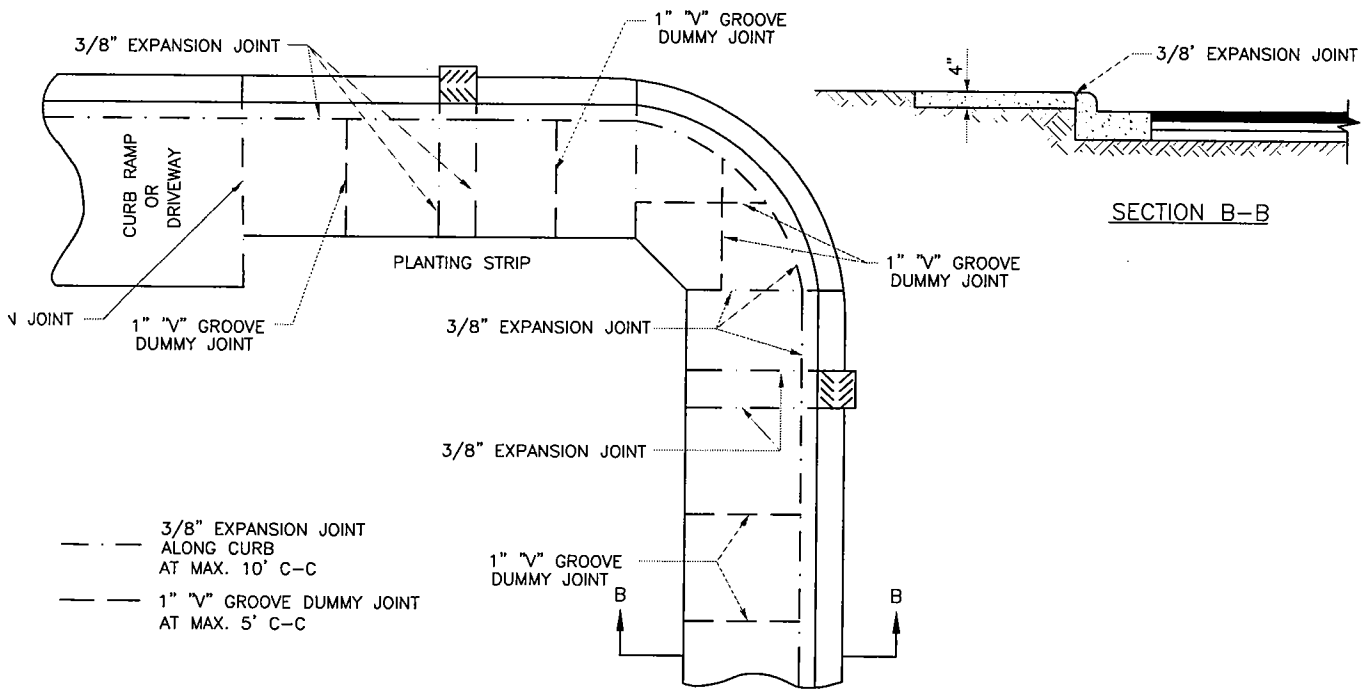

VERTICAL CURB & SIDEWALK

NOTE:

1. SEE SEC. 3.04 FOR JOINT REQUIREMENTS.
2. 1 IN. EDGED GROOVE MAY REPLACE 3/8 IN. EXPANSION JOINT AT INTERFACE BETWEEN CURB AND ADJACENT SIDEWALK FOR SEPERATE POUR CONSTRUCTION.

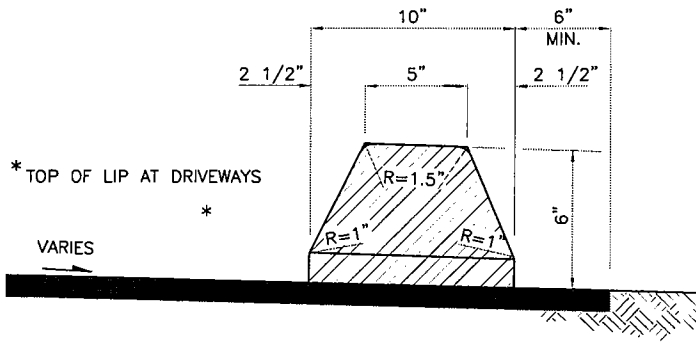

EXTRUDED ASPHALT OR CEMENT
CONCRETE CURB ③ ⑤

NOTE:
FACE OF CURB SHALL NOT
EXCEED FACE OF GUARDRAIL

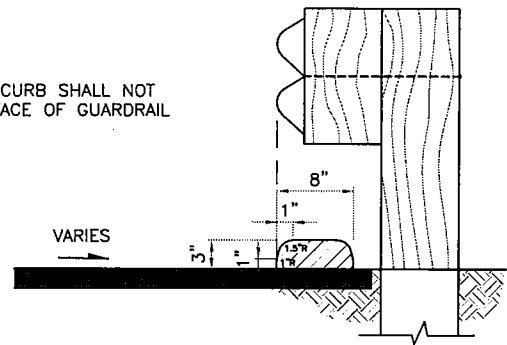

EXTRUDED CONCRETE CURB
UNDER GUARDRAIL ⑥

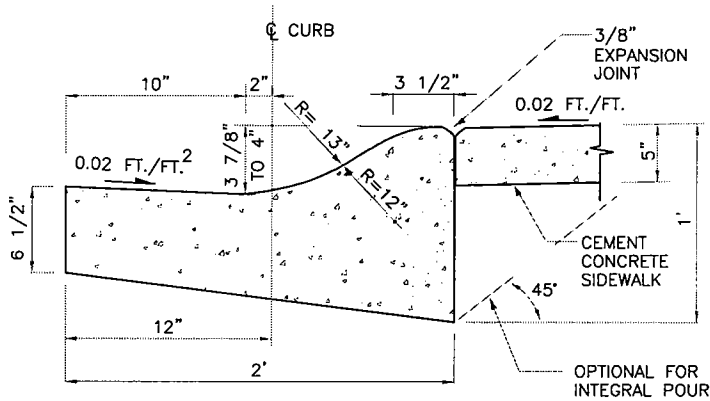

CEMENT CONCRETE ROLLED CURB

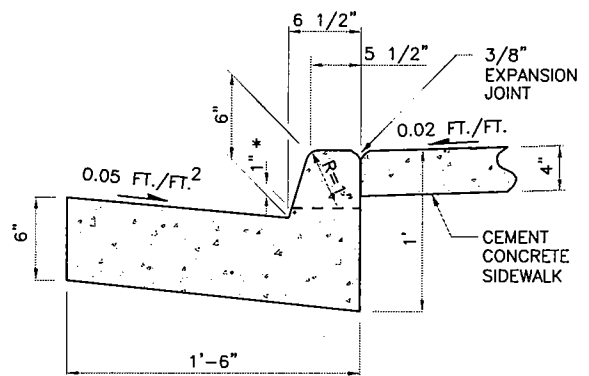

CEMENT CONCRETE VERTICAL CURB & GUTTER

NOTES:

1. SEE SEC. 3.04 K.C.R.S. FOR JOINT REQUIREMENTS.
2. ROLL GUTTER TO MATCH POSITIVE SUPERELEVATION.
- ③ SEE FIG. NO. 2-005 FOR CONFIGURATION OF FILL AND WALKWAY BEHIND CURB IF REQUIRED.
4. 1 IN. EDGED GROOVE MAY REPLACE 3/8 IN. EXPANSION JOINT AT INTERFACE BETWEEN CURB AND ADJACENT SIDEWALK FOR SEPERATE POUR CONSTRUCTION.
- ⑤ SEE SEC. 3.03 FOR EXTRUDED CURB ANCHORAGE.

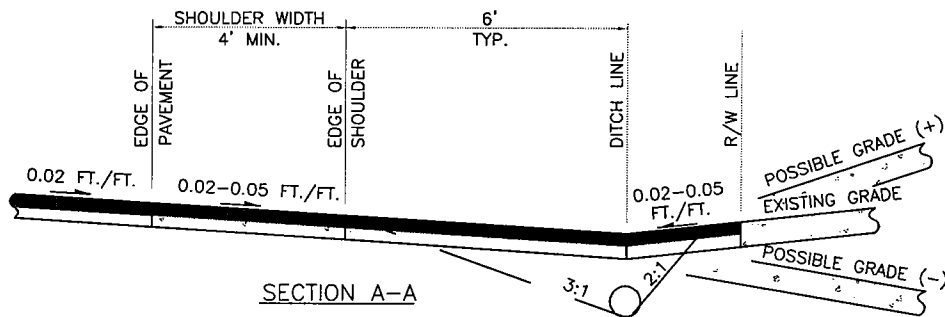
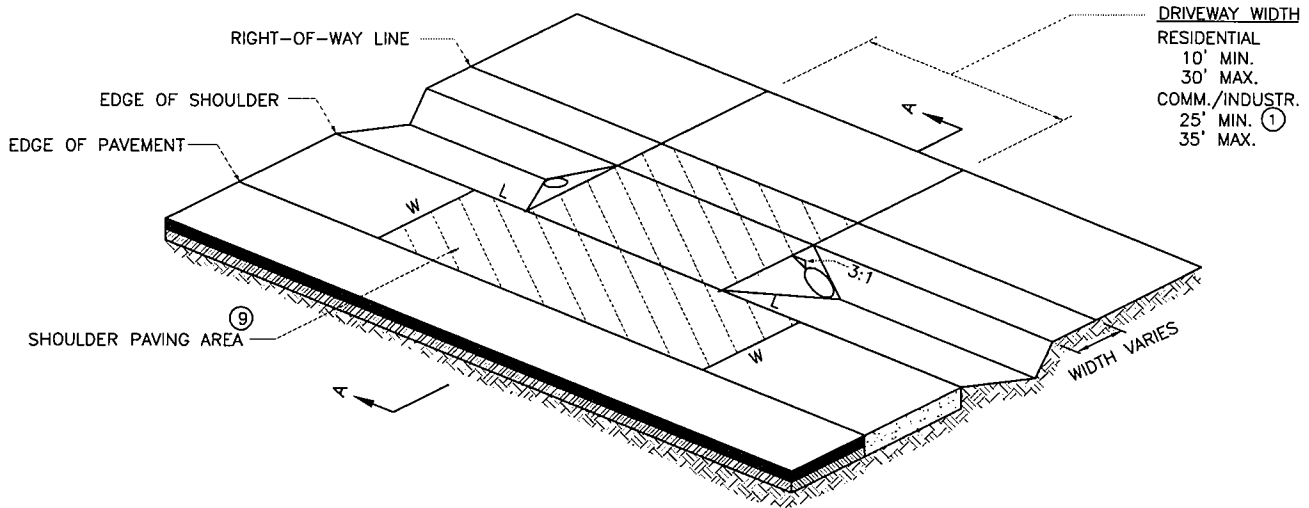

NOTES:

- ① PAVED DRIVEWAYS SHALL BE PAVED THROUGH RIGHT-OF-WAY WITH HOT MIX ASPHALT. NO CONCRETE IS ALLOWED TO RIGHT-OF-WAY UNLESS AS SPECIFIED IN SEC.4.02 OR B.S.T., BUT NOT P.C.C.
2. COMMERCIAL/INDUSTRIAL DRIVEWAYS WIDER THAN 35 FT. MAY BE APPROVED BY THE ENGINEER CONSIDERING BOTH TRAFFIC SAFETY AND THE ACTIVITY BEING SERVED. ALL COMMERCIAL/INDUSTRIAL DRIVEWAYS SHALL HAVE AN EXPANSION JOINT LOCATED MID-WIDTH. (SEE SEC. 3.04.)
3. PIPE SHALL BE:
 - A. SIZED TO CONVEY COMPUTED STORM WATER RUNOFF, AND
 - B. MIN. 12 IN. DIAM., AND
 - C. EQUAL TO OR LARGER THAN EXISTING PIPES WITHIN 500 FT. UPSTREAM.
4. EXPOSED PIPE ENDS SHALL BE BEVELED TO MATCH THE SLOPE FACE AND PROJECT NO MORE THAN 2 IN. BEYOND SLOPE SURFACE. PROJECTING HEADWALLS ARE NOT ACCEPTABLE.
5. ALL TYPES OF PIPE SHALL HAVE MIN. 12 IN. COVER TO FINISH GRADE.
6. PIPE SHALL BE INSTALLED IN A STRAIGHT UNIFORM ALIGNMENT AT A MIN. 0.5% SLOPE (0.5 FT. PER 100 FT.) WITH THE DOWNSTREAM END LOWER THAN THE UPSTREAM END.
7. PIPE MAY BE OMITTED IF ROADSIDE DITCH DOES NOT EXIST AND DRIVEWAY DOES NOT BLOCK NATURAL FLOW.
8. DRIVEWAY SLOPE SHALL MATCH TO BACK EDGE OF SHOULDER, BUT SHOULDER SLOPE AND EDGE OF SHOULDER SHALL NOT BE ALTERED AS A RESULT OF DRIVEWAY CONSTRUCTION.
- ⑨ GRAVEL DRIVEWAYS SHALL BE PAVED BETWEEN THE EDGE OF PAVEMENT AND R/W WITH A.C. OR B.S.T. ONLY WITH DIMENSIONS $L=W$.
10. SEE SEC. 3.01 AND 4.01 FOR DRIVEWAY AND SURFACING STANDARDS.
11. PIPING OF DITCHES SHALL BE ALLOWED ONLY WHERE DRIVEWAY ACCESS IS NECESSARY.

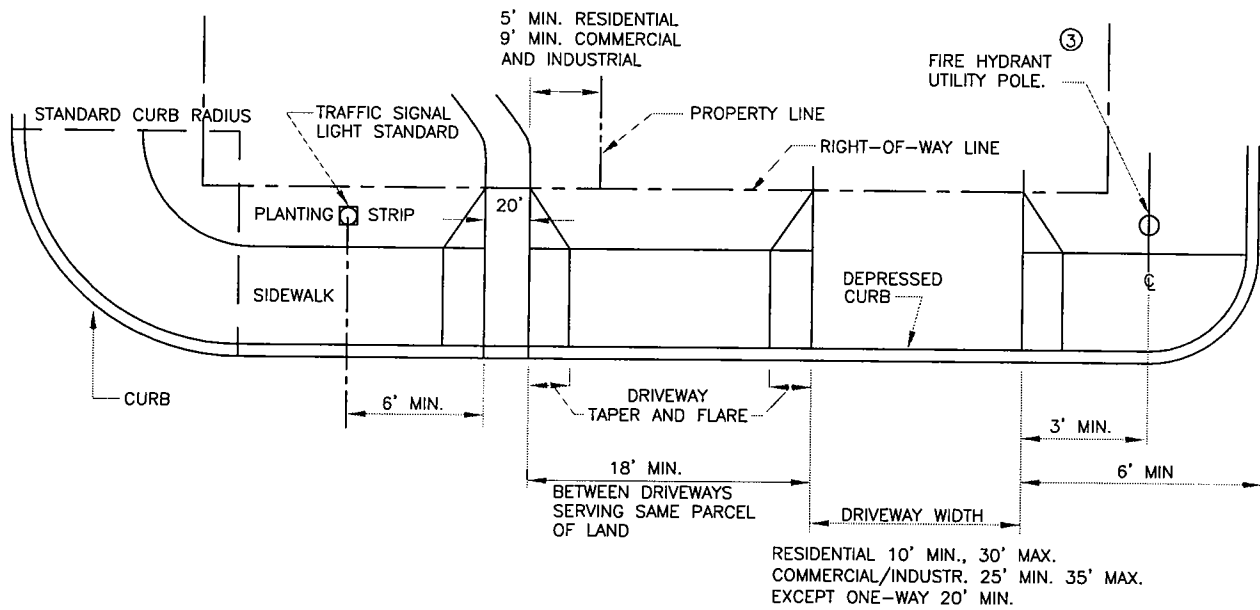

NOTES:

1. NO PORTION OF ANY DRIVEWAY SHALL ENCROACH IN CURB RETURN.
2. COMMERCIAL/INDUSTRIAL DRIVEWAYS MUST BE APPROVED BY THE ENGINEER, CONSIDERING BOTH TRAFFIC SAFETY AND THE ACTIVITY BEING SERVED. ALL COMMERCIAL/INDUSTRIAL DRIVEWAYS SHALL HAVE AN EXPANSION JOINT LOCATED MID-WIDTH. (SEE SEC. 3.04.)
- ③ SEE SEC. 8.02(G) AND FIG. 5-001 FOR ROADWAY CLEARANCE OF UTILITY POLES AND STRUCTURES.
4. DRIVEWAYS SHALL BE LOCATED AS FAR FROM THE INTERSECTION AS POSSIBLE.
5. COMMERCIAL/INDUSTRIAL DRIVEWAYS WIDER THAN 35 FT. MAY BE APPROVED BY THE ENGINEER CONSIDERING TRAFFIC SAFETY AND NEEDS OF THE ACTIVITY SERVED. ALL COMMERCIAL/INDUSTRIAL DRIVEWAYS SHALL HAVE AN EXPANSION JOINT LOCATED MID-WIDTH. (SEE SEC. 3.04)
6. SEE SEC. 3.01 FOR DRIVEWAY STANDARDS.
7. SEE SEC. 4.01 FOR SURFACING REQUIREMENTS.

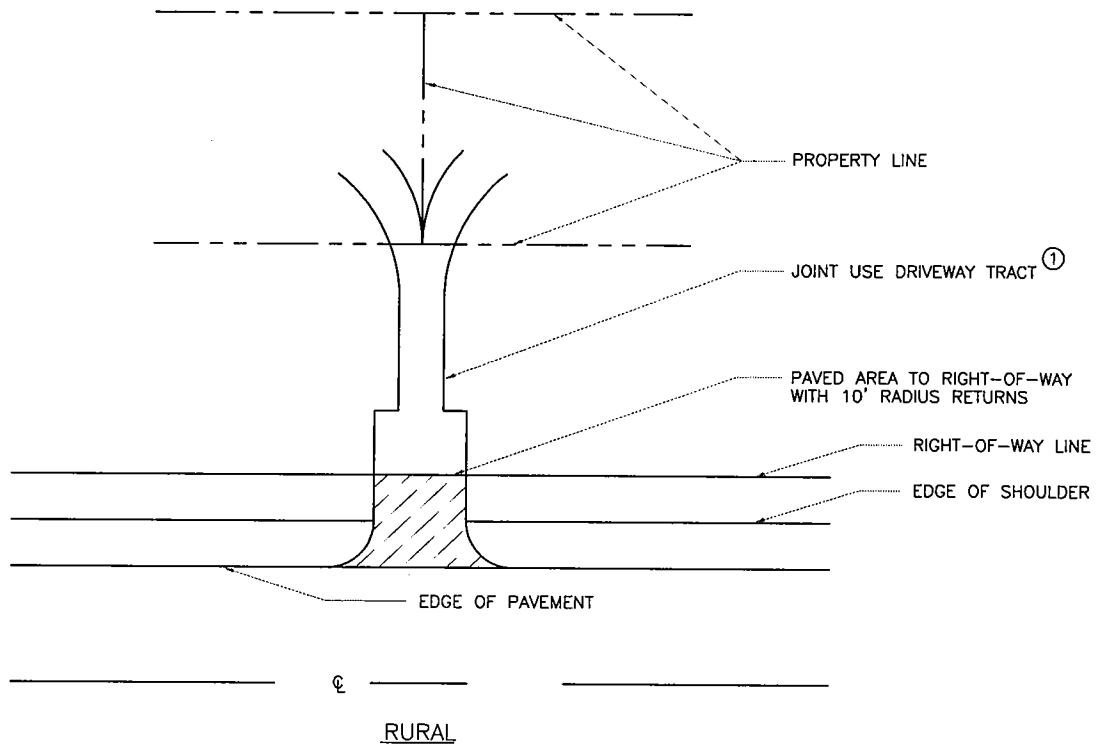
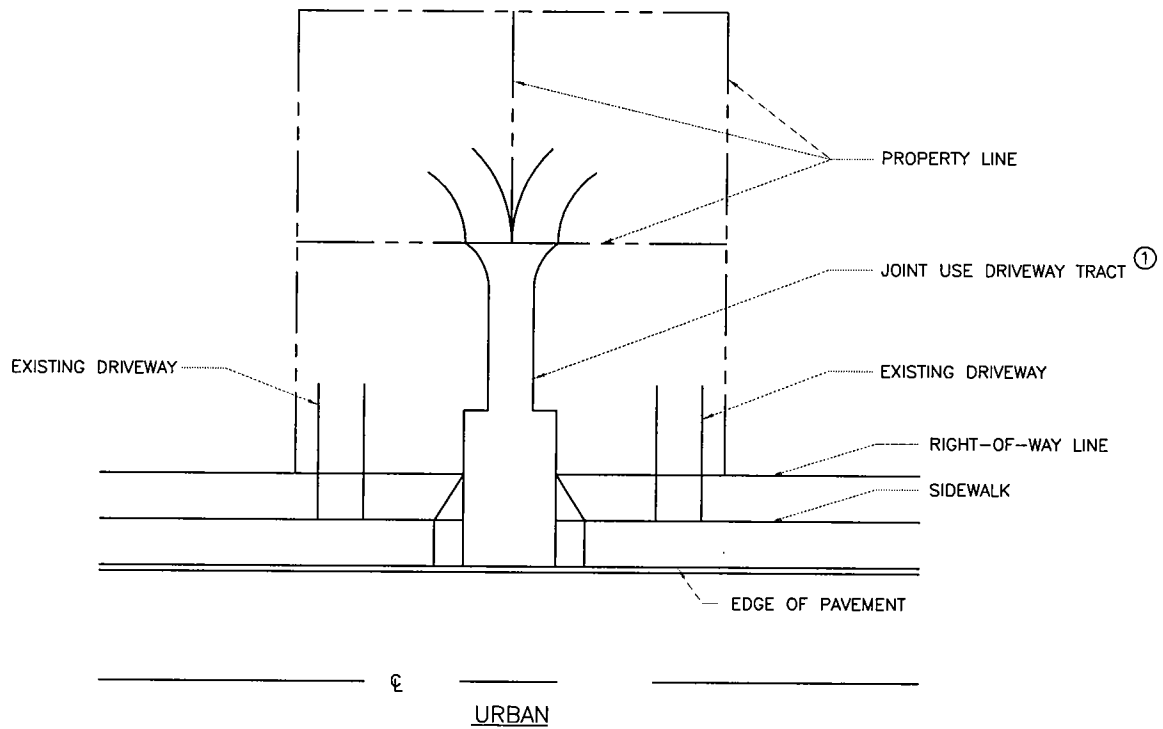

NOTE:

- ① SEE SEC. 3.01 FOR TRACT WIDTH AND PAVING REQUIREMENTS.
- 2 SEE FIGS. 3-012, 3-013, AND 3-014 FOR DESIGN REQUIREMENTS.

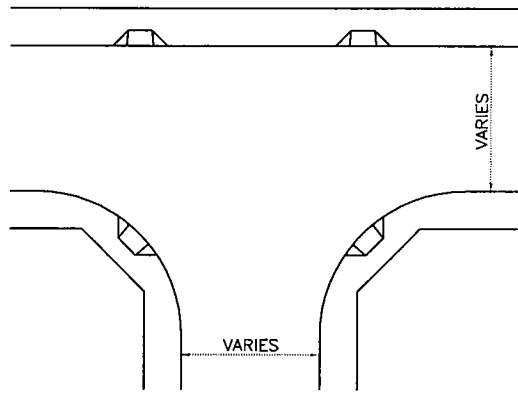

ACCEPTABLE
RAMP LOCATIONS
FOR RETROFIT OR ALTERATION

NON ARTERIAL RAMP LOCATIONS

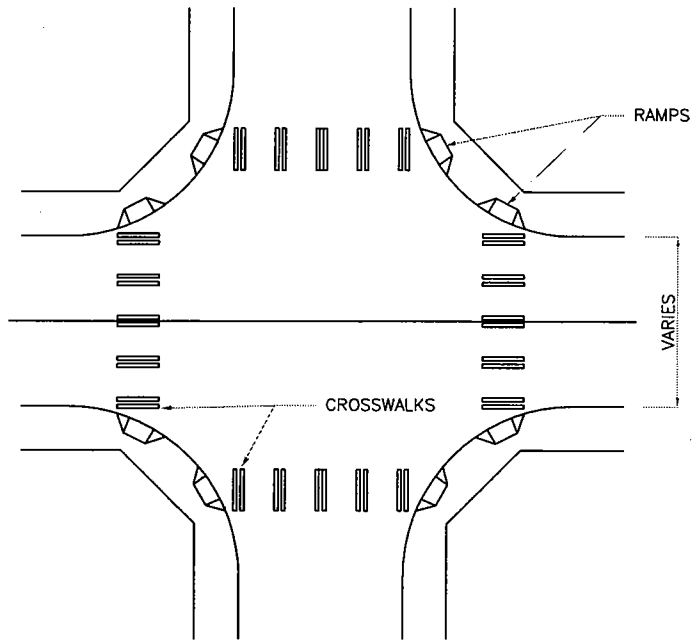

ARTERIAL RAMP LOCATIONS

FOR NEW CONSTRUCTION
OR STANDARD RECONSTRUCTION

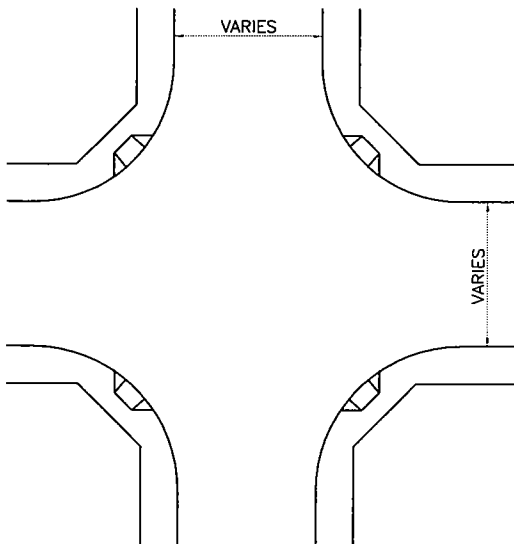

NOTES:

1. CATCH BASIN AND INLETS SHALL BE OUTSIDE THE CURB RAMP (32 IN. MIN. CLEARANCE FROM RAMP). SEE SEC. 7.05 FOR CROSSWALK RESTRICTIONS.
2. CARE SHALL BE TAKEN TO KEEP THE RAMP FROM CONFLICTING WITH HYDRANTS, POLES, INLETS, AND OTHER UTILITIES.
3. CONSTRUCT RAMP IN ACCORDANCE WITH FIGS. 3-007, 3-008 AND 3-009.
4. CROSSWALKS ARE NOT ALWAYS MARKED.
5. WHEN RAMPS ARE CONSTRUCTED ON ONE SIDE OF STREET, RAMPS SHALL BE ALIGNED WITH COMPANION CROSSINGS ON OPPOSITE SIDE OF STREET.

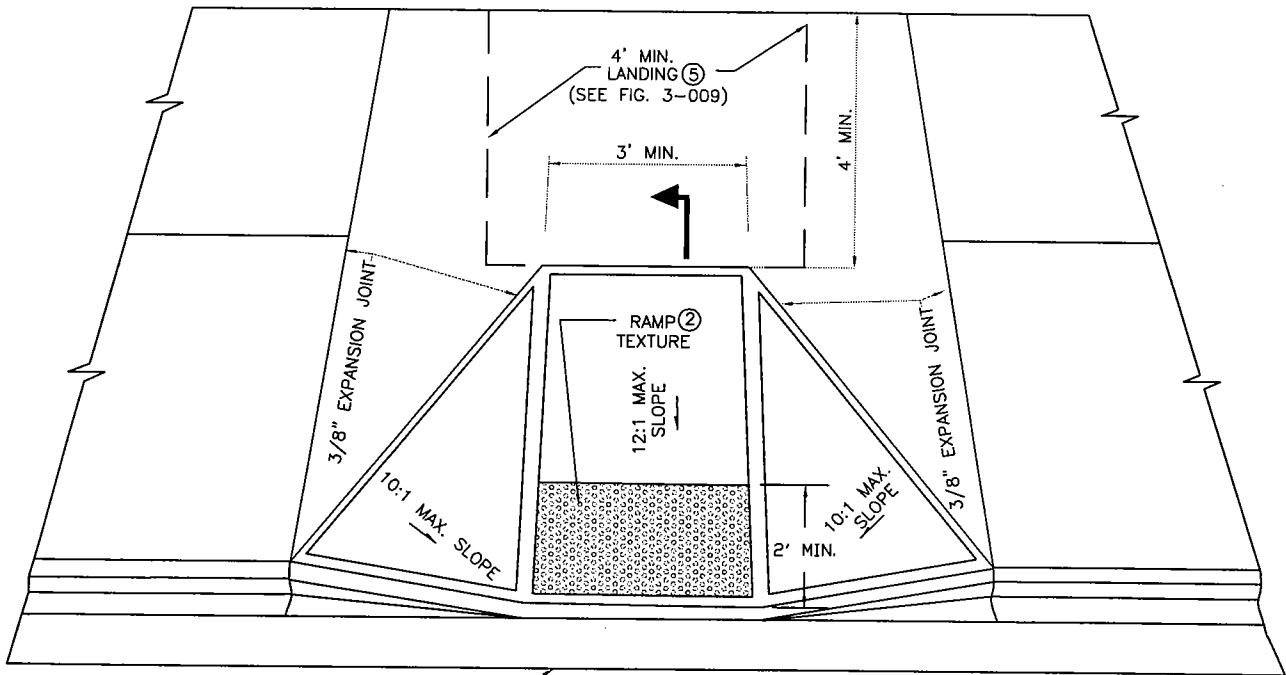

NOTES:

1. RAMP AND APPROACHES HAVE MINIMUM 32 IN. CLEARANCE FROM OBSTACLES INCL. HYDRANTS, POLES, AND INLETS.
- ② RAMP SHALL BE TEXTURED USING TRUNCATED DOME PATTERN. (SEE DETAIL BELOW.)
3. RAMP CENTER LINE SHALL BE PERPENDICULAR TO OR RADIAL TO CURB RETURNS UNLESS OTHERWISE APPROVED BY THE COUNTY ROAD ENGINEER.
4. RAMPS SHALL BE CONSTRUCTED AT CORRESPONDING SIDEWALK LOCATIONS ON OPPOSITE SIDE OF STREETS WHEN RAMPS ARE CONSTRUCTED ON ONE SIDE OF STREET. SEE FIG. 3-006.
- ⑤ LANDING SHALL BE MINIMUM 4 X 4'. (REFER TO FIG. 3-008.)
6. RAMPS SHALL BE CONTRASTING COLOR OF LIGHT TO DARK OR DARK TO LIGHT AND COLORING MUST BE AN INTEGRATED PART OF THE RAMP.

FLUSH

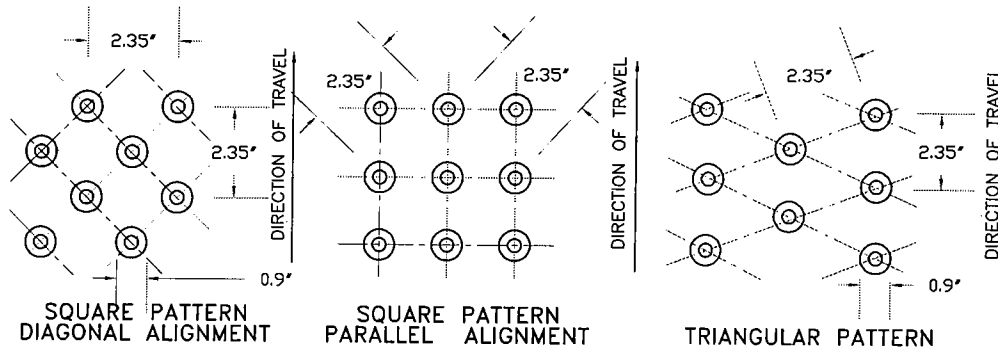
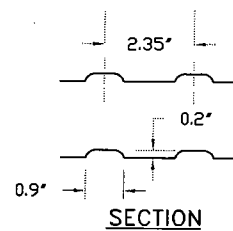
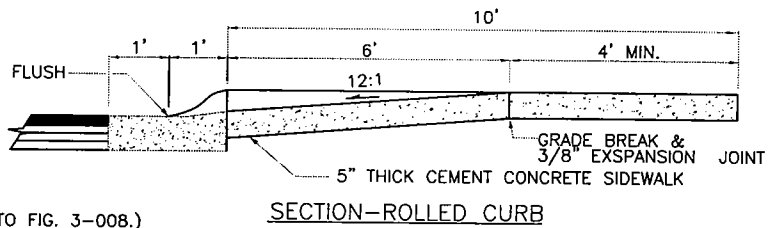
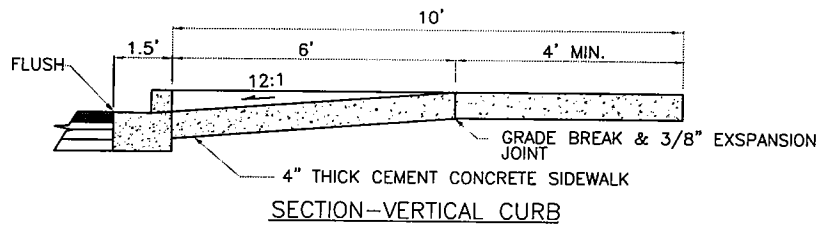

PLAN TRUNCATED DOMES

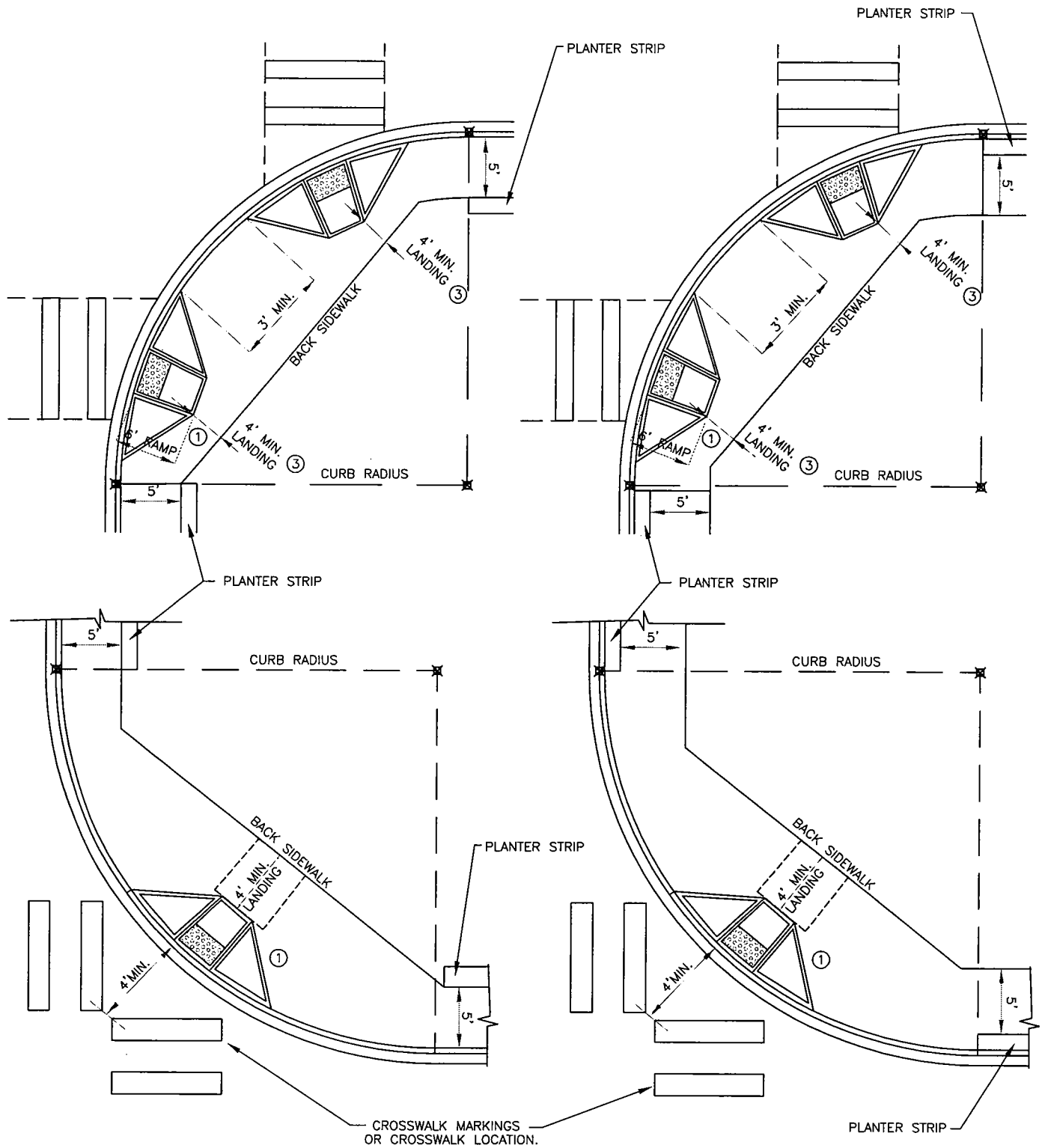

NOTE:

- ① RAMPS SHALL BE CONTRASTING COLOR OF LIGHT TO DARK OR DARK TO LIGHT AND COLORING MUST BE AN INTEGRATED PART OF THE RAMP.
2. CONSTRUCT RAMPS IN ACCORDANCE WITH FIG. 3-007.
- ③ LANDING SHALL BE A MINIMUM 4' X 4'.

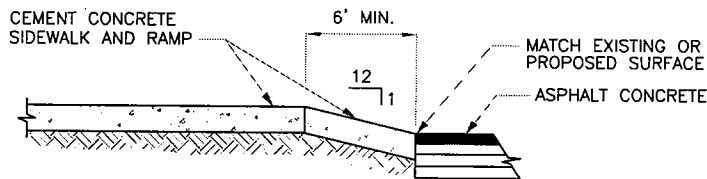
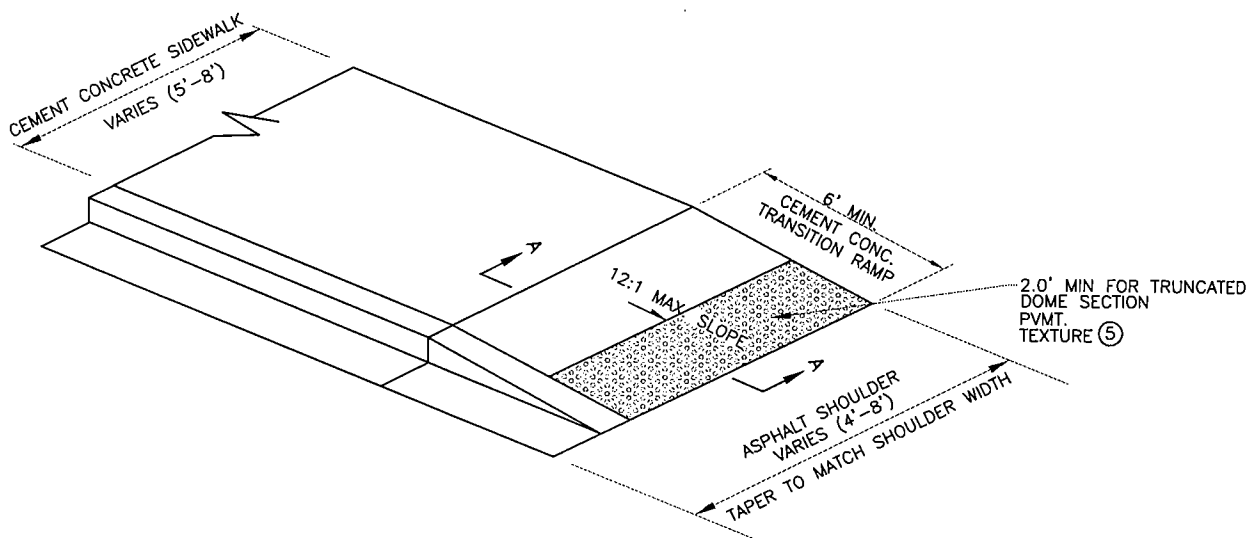

SECTION A-A

NOTES:

1. SEE SEC. 3.02 FOR SIDEWALK WIDTHS.
2. SEE SECS. 2.02 AND 2.03 FOR PAVEMENT AND SHOULDER WIDTHS.
3. SHOULDER SHALL BE SURFACED AS REQUIRED BY SECS. 3.07 AND 4.01. PAVED SHOULDER SLOPE SHALL MATCH CROWN SLOPE OR 0.02 FT./FT.
4. SEE FIG. 3-001 FOR CURB AND SIDEWALK JOINTS.
- ⑤ RAMP SHALL BE TEXTURED USING TRUNCATED DOME PATTERN. (SEE FIG. 3-007.)
6. THIS DETAIL APPLIES TO ROLLED AND VERTICAL CURB ROADWAYS.

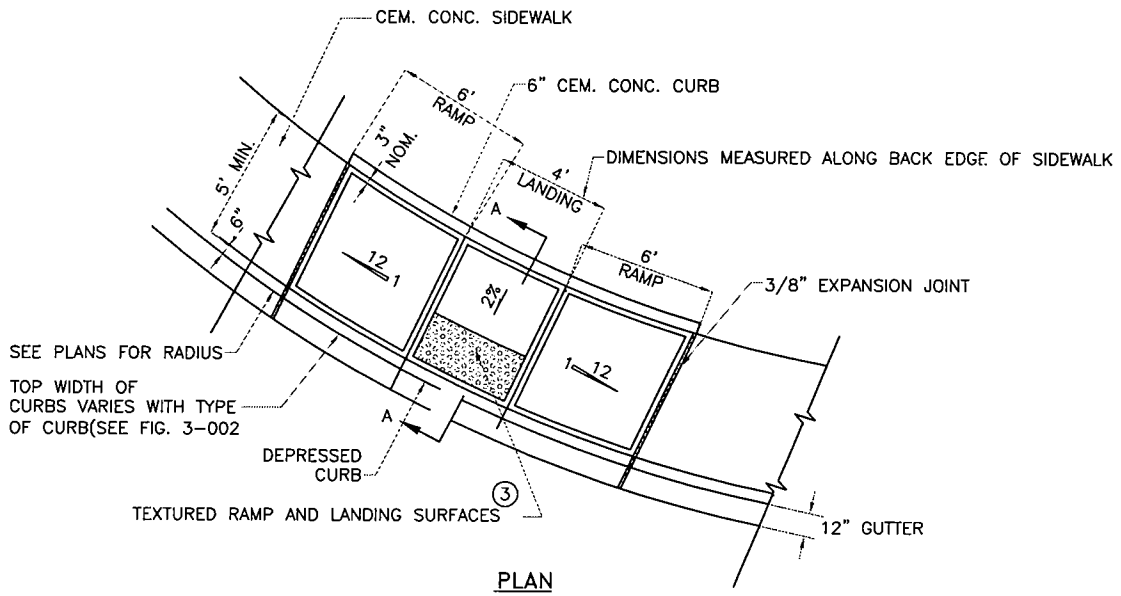
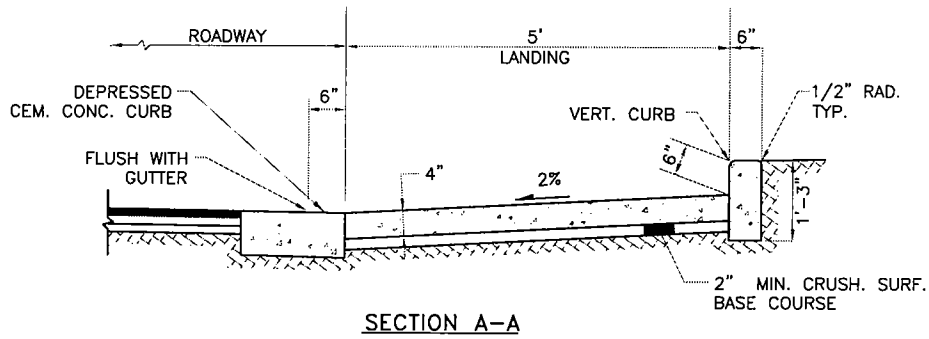
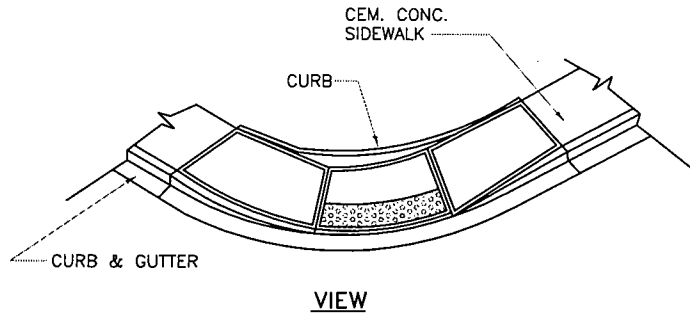

- NOTES:
1. THIS DESIGN WILL ONLY BE UTILIZED WHEN OTHER OPTIONS TO MEETING ADA STANDARDS FOR SIDEWALK RAMPS HAVE BEEN EXHAUSTED. REFER TO FIG. 3-009.
 2. THIS OPTION IS ONLY ALLOWED WITH PERMISSION OF THE KING COUNTY ROAD ENGINEER.
 - ③ RAMP SHALL BE TEXTURED USING TRUNCATED DOME PATTERN. (SEE FIG. 3-007.)

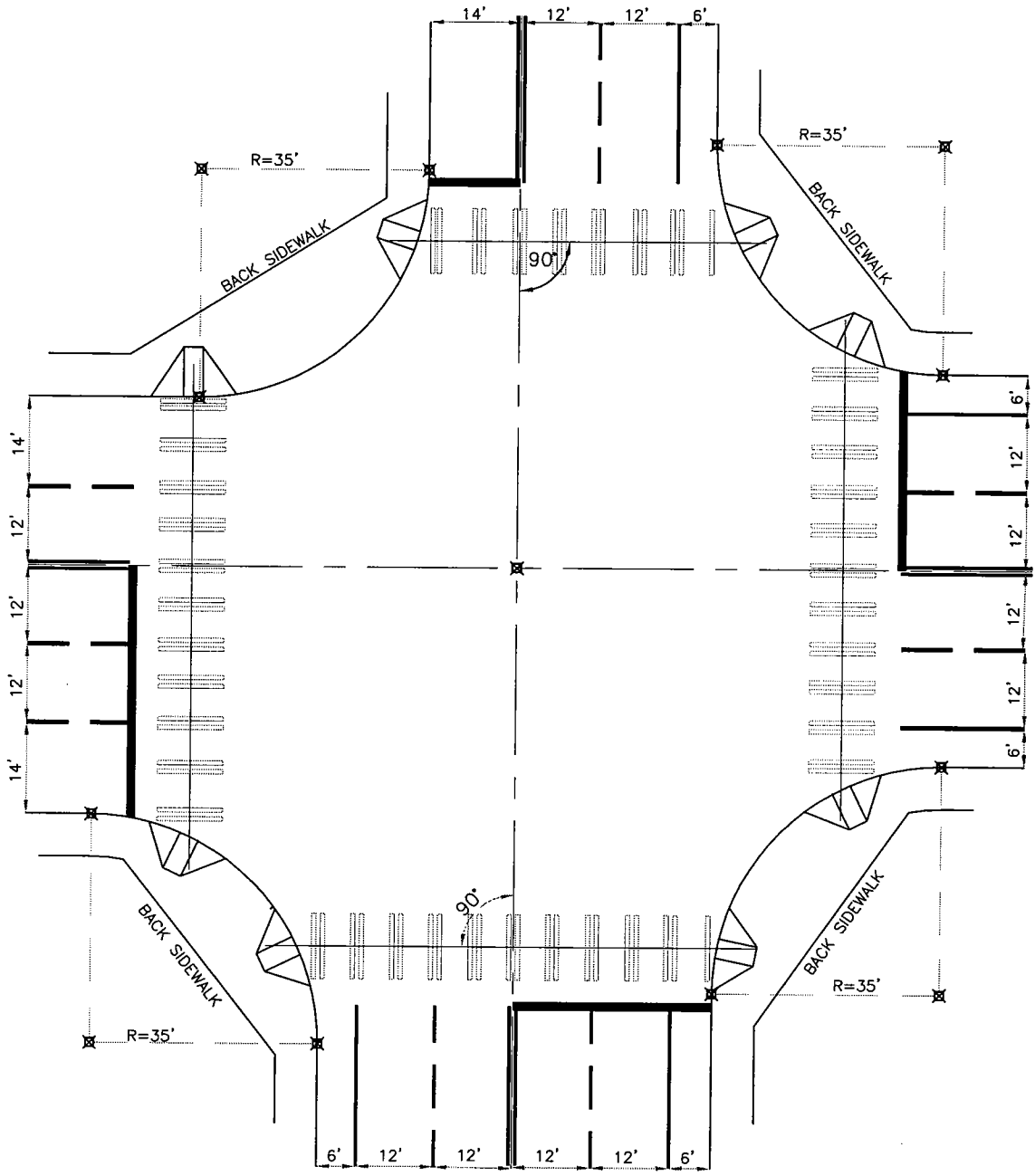

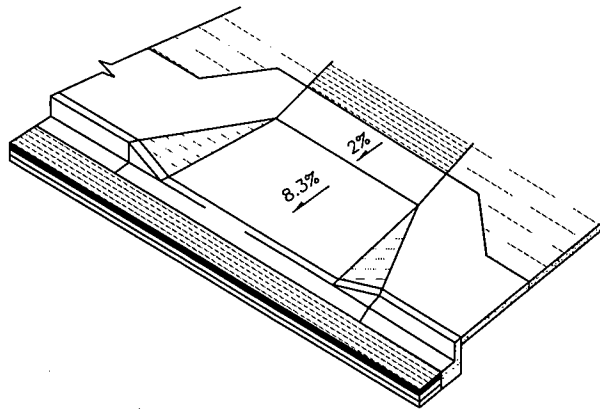

VIEW

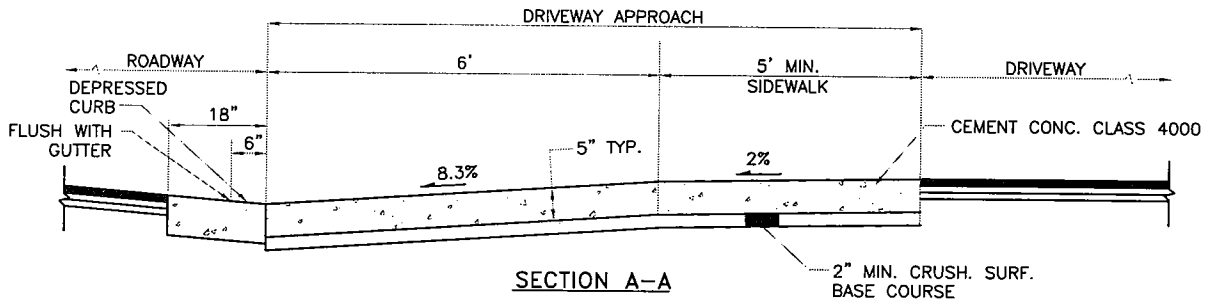

SECTION A-A

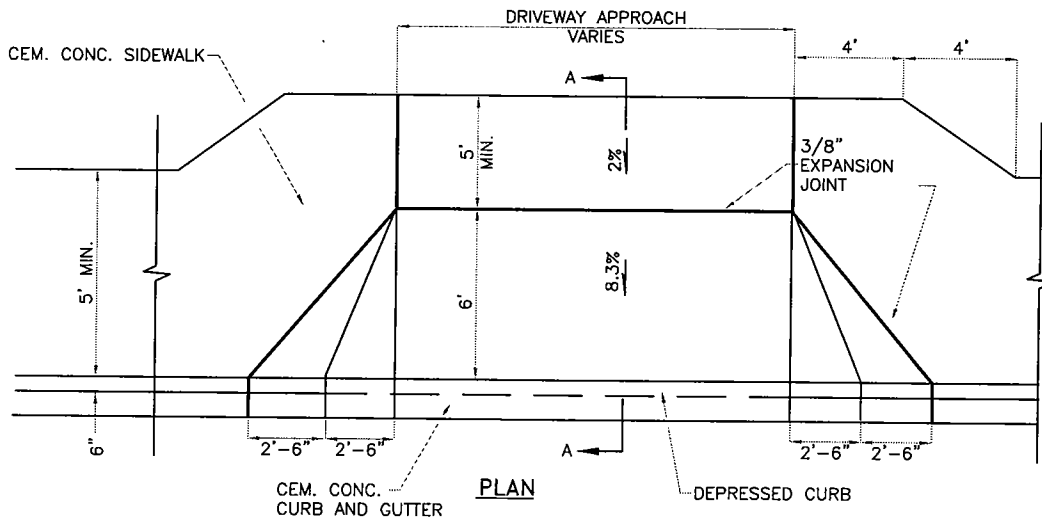

PLAN

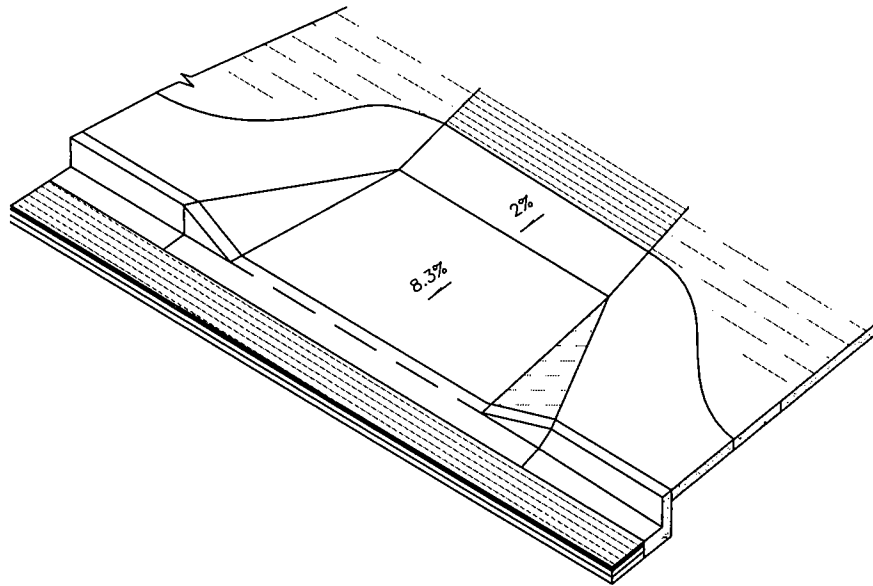

VIEW

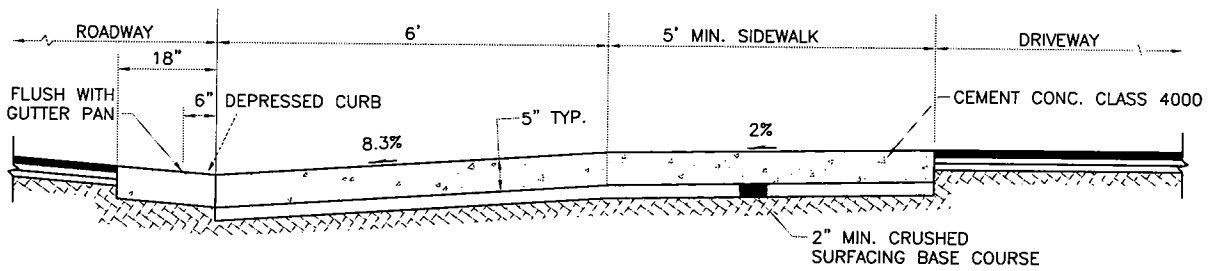

SECTION A-A

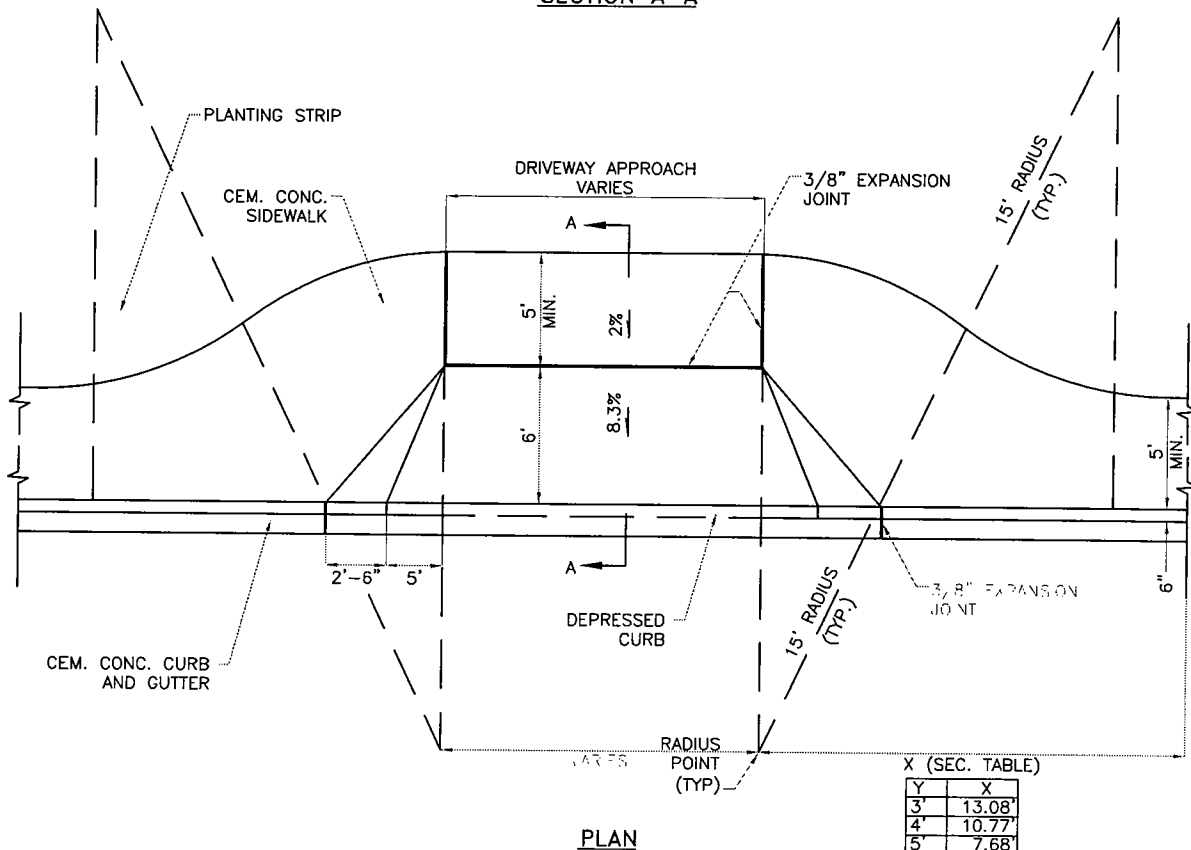

PLAN

Y	X
3'	13.08'
4'	10.77'
5'	7.68'

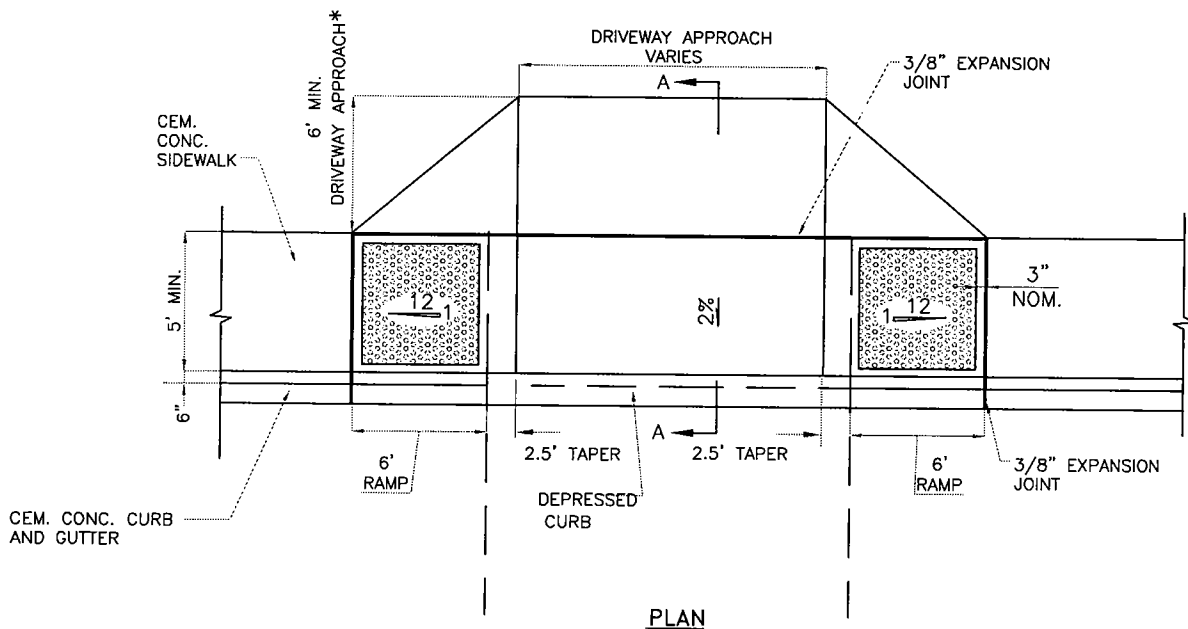
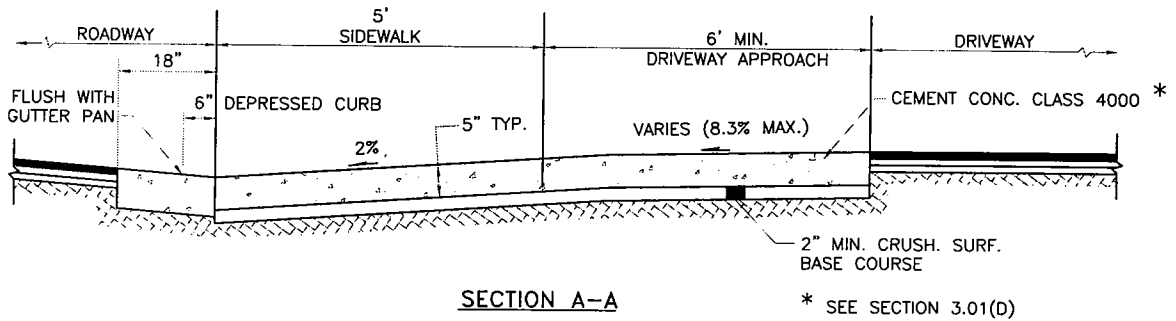
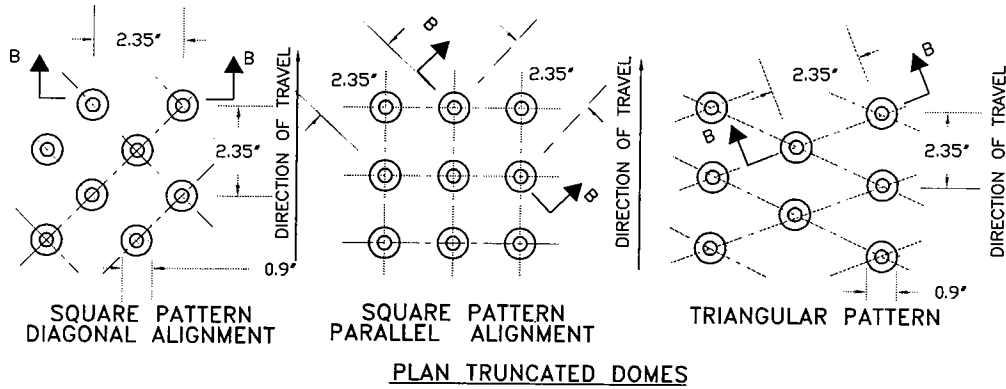
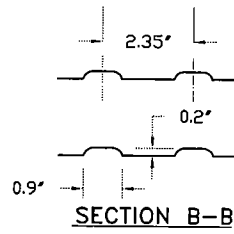
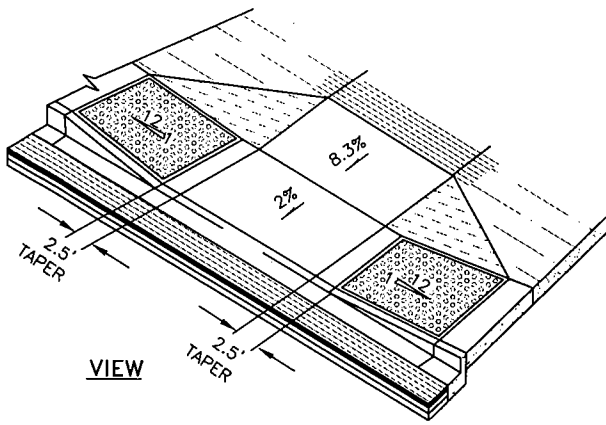

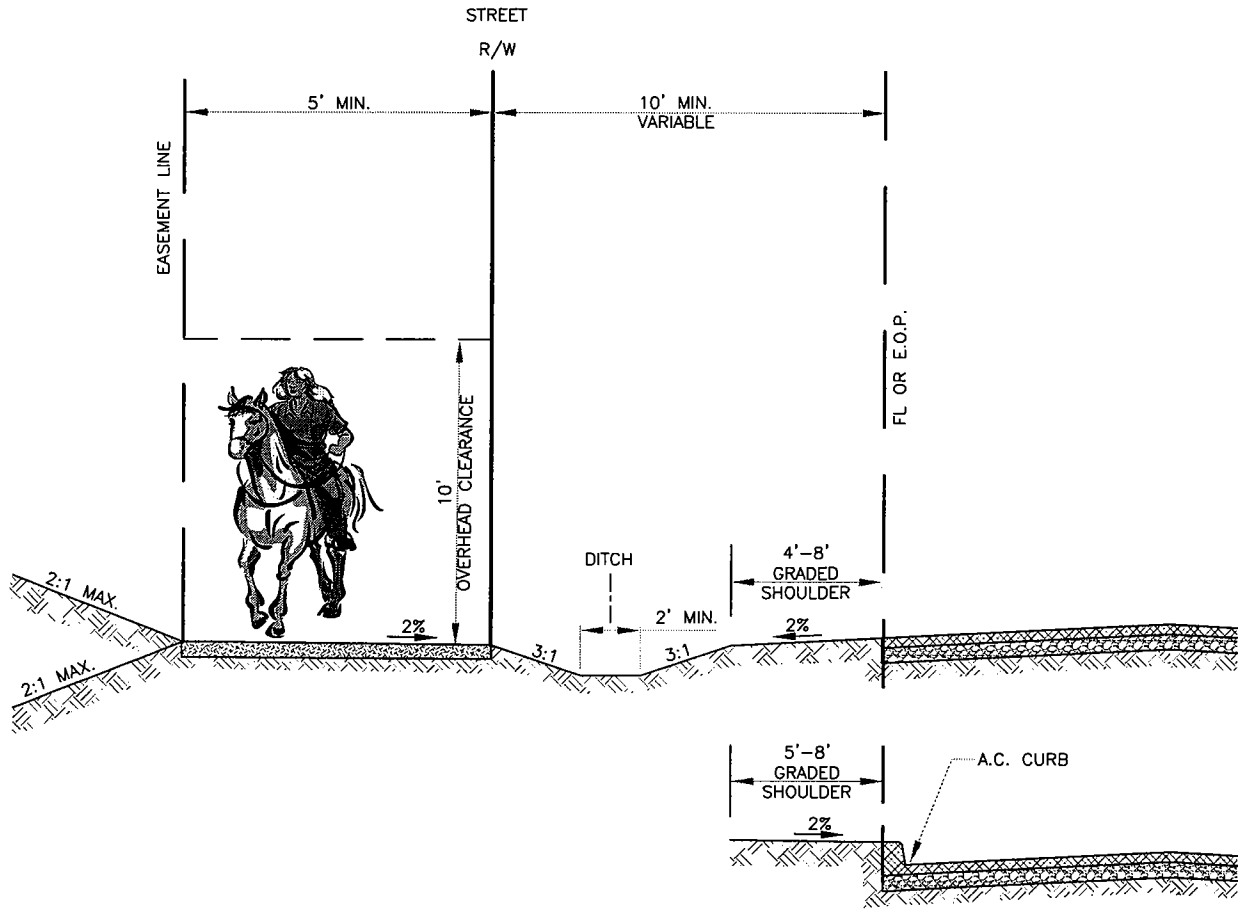

NOTES:

1. DITCH SECTION AS REQUIRED BY ROAD CLASSIFICATION.
2. PAVED SHOULDER IF ARTERIAL OR NEIGHBORHOOD COLLECTOR

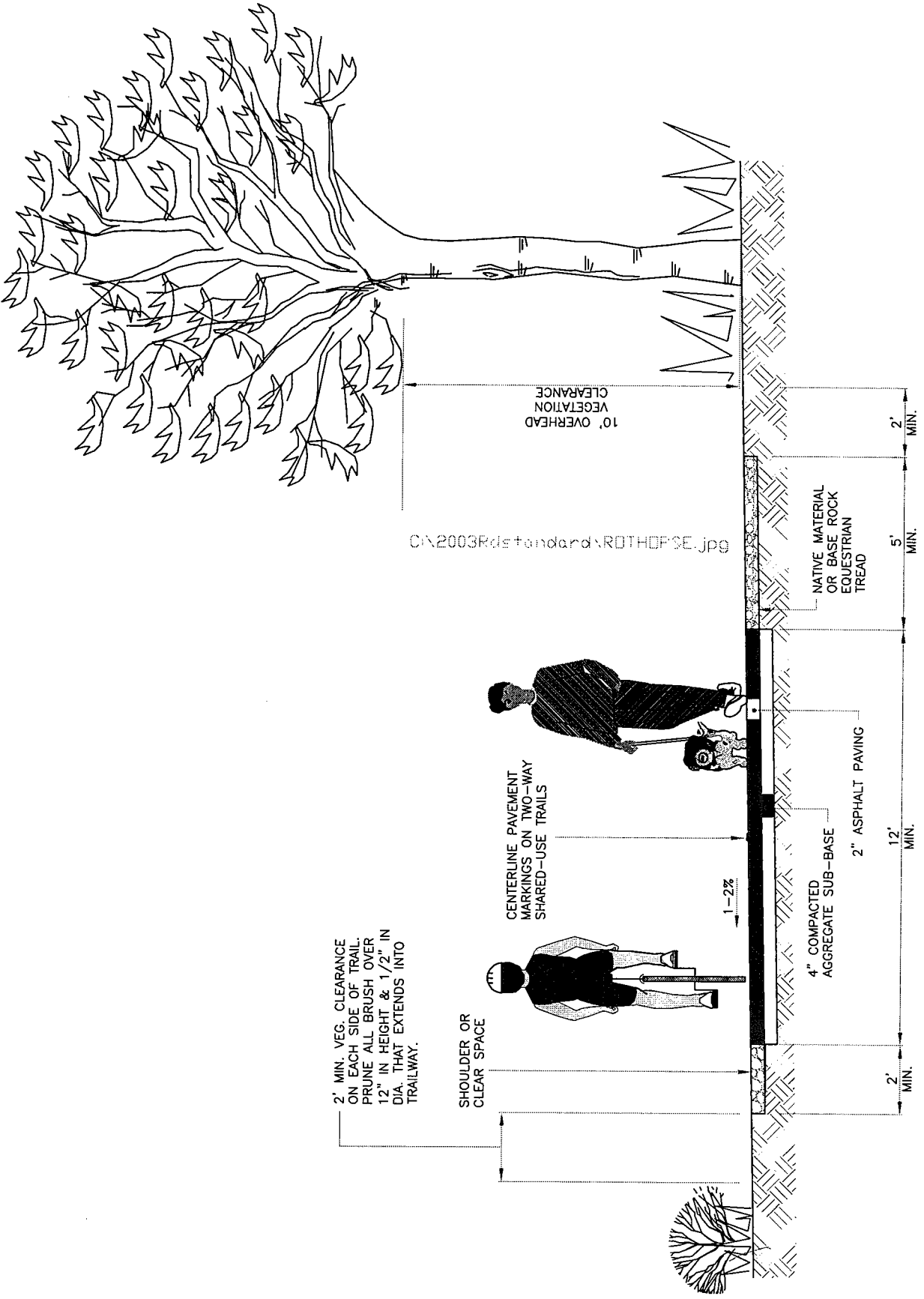

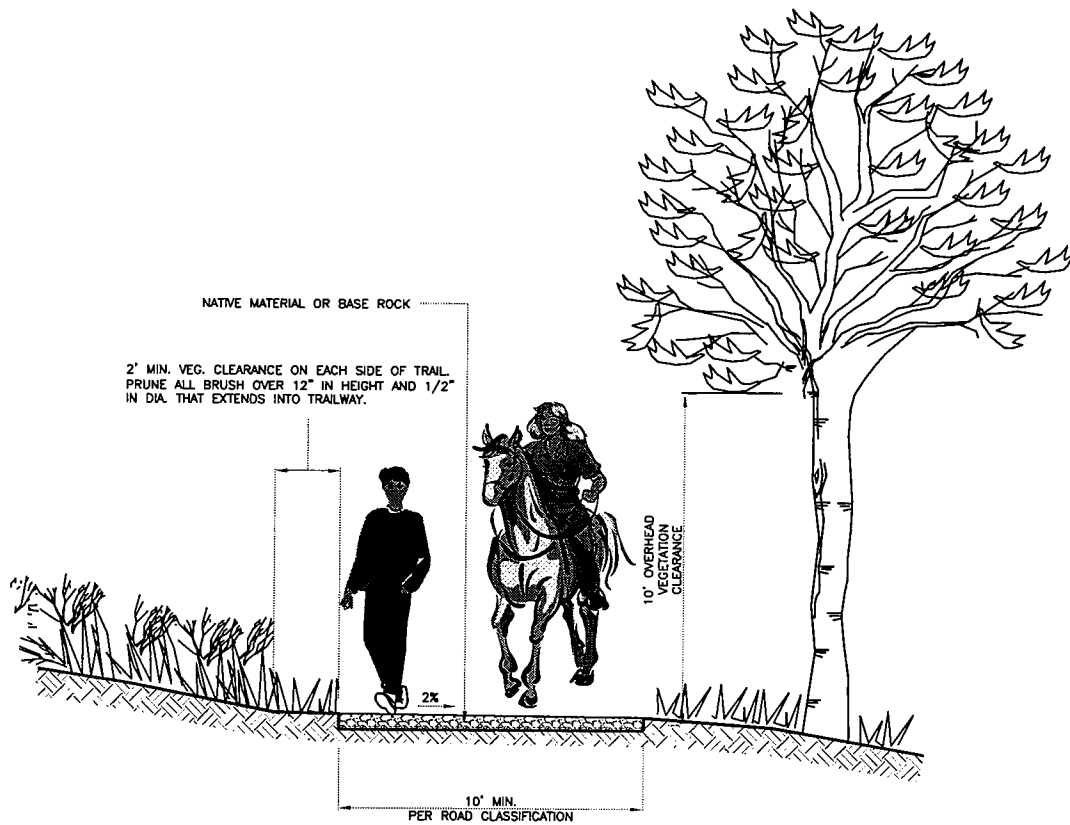

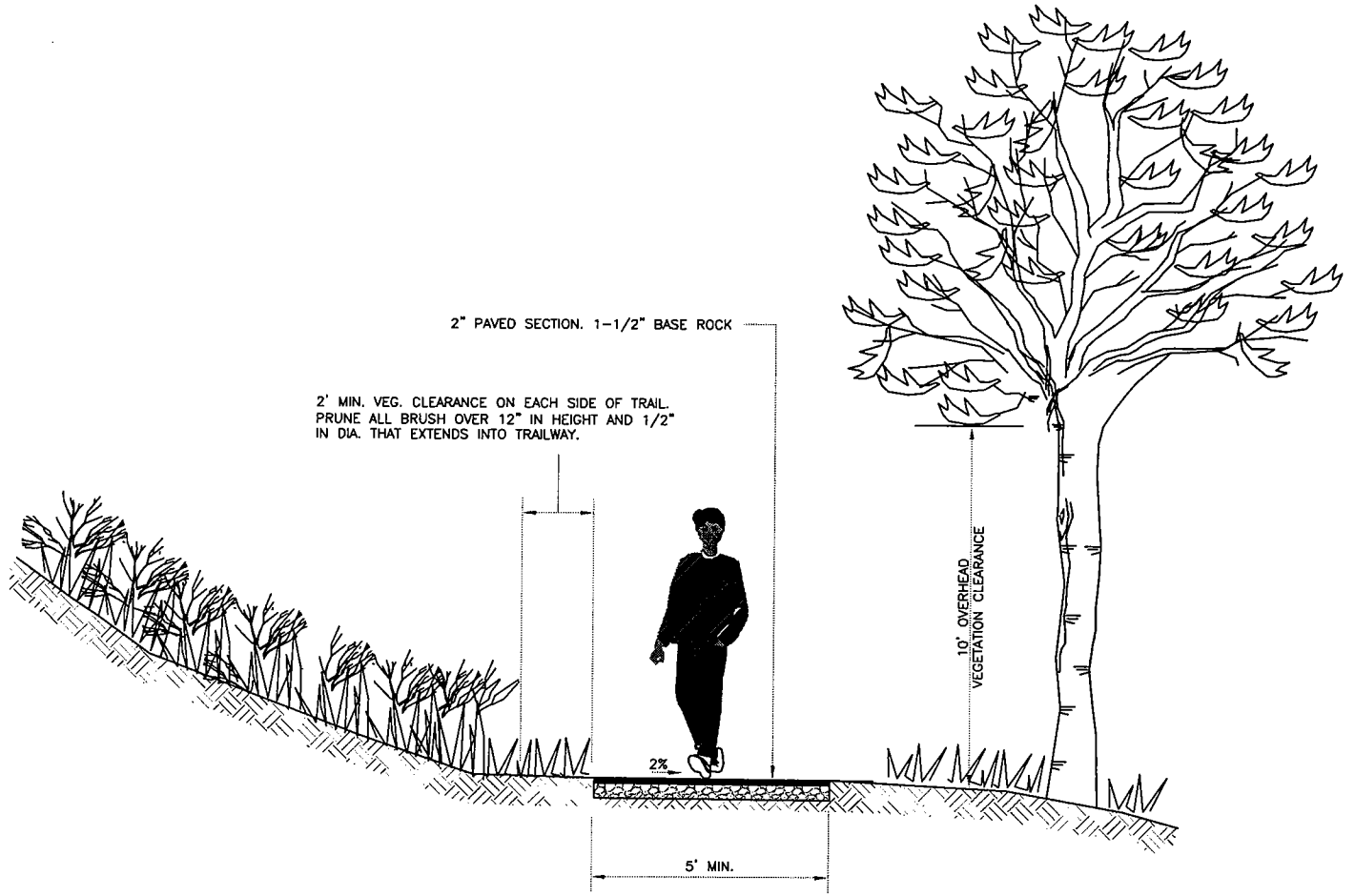

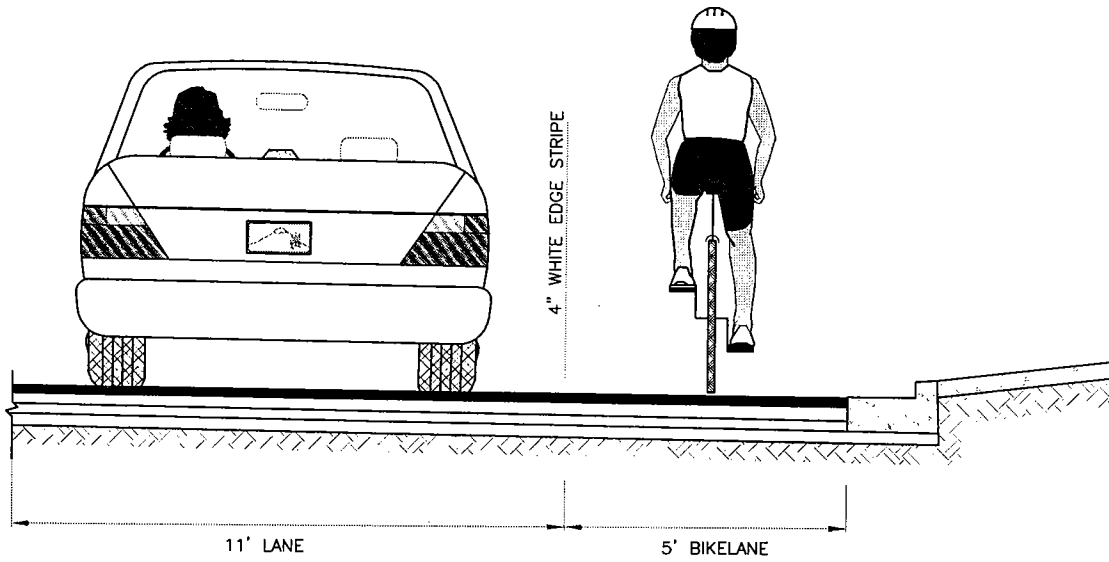

DELINEATED BIKELANE

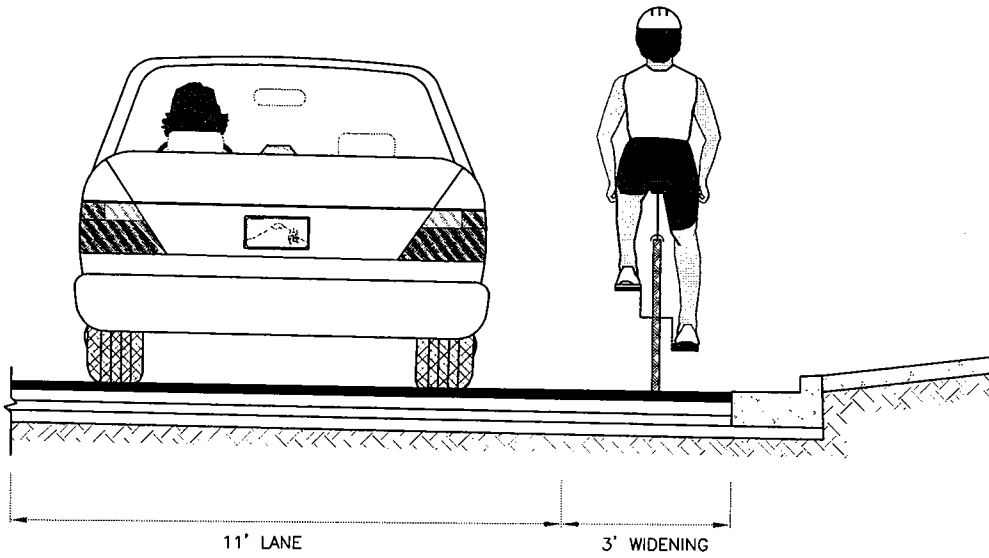

SHARED ROADWAY

CHAPTER 4. SURFACING

4.01 Residential Streets, Sidewalks, Walkways, and Bikeways

The minimum paved section, with alternative combinations of materials, for new and reconstructed residential streets, lanes, shoulders, sidewalks and bikeways shall be as indicated in Table 4-1. These sections are acceptable only on stable compacted subgrade constructed with suitable materials. Any proposed exception to these materials will be subject to soils strength testing and traffic loading analysis, and subject to review and approval by the County Road Engineer as outlined in Section 4.04 below. At any time during construction, should a question on the suitability or placement of native soil or import materials exist, the inspector may require a geotechnical evaluation to address soil conditions. When required, the report shall be prepared, stamped, and signed by a licensed civil engineer registered in the State of Washington and include an assessment of the site conditions and recommendations for corrective actions. A copy of maximum density curves and all associated compaction test reports shall be included with the report. All materials shall meet the requirements of the WSDOT Standard Specifications unless otherwise approved.

**Table 4-1
Residential Streets, Walkways and Bikeways**

TYPE OF FACILITIES	HOT MIX ASPHALT (HMA) CLASS 1/2"	HMA CLASS 3/4" or 1"1	BITUMINOUS SURFACE TREATMENT	CRUSHED SURF. TOP COURSE	CRUSHED SURF. BASE COURSE	PORTLAND CEMENT CONCRETE
RESIDENTIAL STREETS						
Preferred Design Section	2"	4"				
Optional Design Section ²	3"			1½"	8"	
Rural Design Section for designated agricultural production districts and private rural minor access streets, on grades not steeper than 12 percent			Class A	1½"	2½"	

TYPE OF FACILITIES	HOT MIX ASPHALT (HMA) CLASS 1/2"	HMA CLASS 3/4" or 1"	BITUMINOUS SURFACE TREATMENT	CRUSHED SURF. TOP COURSE	CRUSHED SURF. BASE COURSE	PORTLAND CEMENT CONCRETE
Optional Rural Design Section for private rural minor access streets, on grades not steeper than 12 percent				1½"	2½"	
SHOULDERS						
Preferred Design Section	2"	4"				
Optional Design Section ² I	3"			1½"	8"	
Optional Design Section II (Subcollectors, Subaccess, Minor Access Roadways, and Equestrian Routes)				1½"	2½"	
SIDEWALKS						
Vertical Curb Design Section						4" Class 4000,
Rolled Curb Design Section						5" Class 4000,
WALKWAYS & BIKEWAYS ^{3*}						
Alternative I	2"			1½"	2½"	
Alternative II	3½"					
Alternative III						5" Class 4000, (20 MPa)

Notes:

1. Class ¾" or 1" is acceptable.
2. The optional roadway design section can be used when the following criteria is met:
 - a. The top two (2) feet of subgrade meets the requirements for Gravel Borrow in accordance with the WSDOT/APWA Standard Specifications, and
 - b. Paving only will take place between May 1st and September 30th, and
 - c. Paving shall begin within five (5) working days of a passing subgrade proof roll, provided the weather permits, and the subgrade is suitable.
3. When a walkway or bikeway is incorporated into a road shoulder, the required shoulder section, if higher strength shall govern. Subgrade compaction for bikeways and paved walkways shall meet a minimum of 95 percent maximum density.

4.02 Driveway Surfacing

Driveways may be surfaced as desired by the owner, except:

1. On curbed streets with sidewalks, driveway shall be paved with Portland cement concrete Class 4000 (28 MPa) from curb to back edge of sidewalk. See figures 3-012, 3-0013 and 3-014.
2. On shoulder and ditch section, driveway between edge of pavement and right-of-way line shall be HMA as required by figure 3-003.
3. On thickened edge roadways with underground utilities, Portland cement concrete may be used for driveways between the thickened edge and the right-of-way line provided that a construction joint is installed at the right-of-way line.

4.03 Street Widening

1. When an existing asphalt paved street is to be widened, the edge of the driving lane shall be saw cut to provide a clean, vertical edge for joining to the new asphalt. After placement of the new asphalt section, the joint shall be sealed and the street overlaid with a minimum of 1.5-inch HMA, Class 1/2", plus a prelevel course, full width throughout the widened area. All failures and cracking on road surfaces must be repaired prior to the overlay, see Section 4.06. The limits of the overlay will be based on the condition of existing pavement and the extent of required changes to the surfacing and channelization. When the County Road Engineer or Development Engineer determines that potential impacts from a development warrant subgrade repairs prior to the overlay, the applicant must provide a geotechnical report that includes recommendations for repairing the subgrade. The exception to this requirement must be through the road variance process.

2. If an existing shoulder is proposed to be incorporated into a future traveled way, a pavement evaluation shall be performed. This evaluation shall analyze the structural capacity and determine any need for improvement. Designs based on these evaluations are subject to review and approval by the County Road Engineer or Development Engineer. The responsibility for any shoulder material thickness improvement shall be considered part of the requirement for roadway widening. The shoulder shall be replaced in width as specified in Sections 2.02.
3. Any widening of an existing roadway, either to add traveled way, or paved shoulder, shall have the same surfacing material as the existing roadway.
4. Any widening or channelization will require a full-width overlay, see paragraph one of this section.

4.04 Requirements for Residential Streets on Poor Subgrade

The minimum material thickness indicated in Section 4.01 is not acceptable if there is any evidence of instability in the subgrade. This includes but is not limited to free water, swamp conditions, fine-grained or organic soil, slides or uneven settlement. If any of these characteristics are present, the soil shall be sampled, tested, and designed in accordance with Section 4.05. Both the soils test report and the resulting pavement design will be subject to review and approval by the County Road Engineer.

4.05 Arterials and Commercial Access Streets

Rigid pavement designs for arterial and commercial access streets shall be prepared by a licensed professional civil engineer registered in the State of Washington and in accordance with the current "AASHTO Guide for Design of Pavement Structures." Flexible pavements shall be designed using a layered design analysis in accordance with the "AASHTO Guide for Design of Pavement Structures," 1993 edition. The pavement design shall be based on soil parameters reflecting actual field or laboratory tests, and a traffic loading analysis. A subsurface investigation shall be performed in order to provide information on any materials that would cause settlement, stability, or drainage problems. Soil used for the design analysis shall be representative of the native subgrade conditions. The traffic loading analysis shall include traffic volume, percentage growth rate, and axle loadings. Materials shall meet WSDOT specifications. The following design inputs shall be used for calculation of the pavement:

1. Pavement Design Life = 20 years
2. Reliability (R) = 85%
3. Overall Standard Deviation (S_o) = 0.50
4. Design Serviceability Loss (ΔPSI) = 1.5
5. Drainage Coefficient (m) ≤ 1.0

Layer Coefficients

- a) Hot Mix Asphalt: ≤ 0.44
 - b) Crushed Surfacing: ≤ 0.14
7. Resilient Modulus (M_r)
- a) HMA: $M_r = 450,000$ psi
 - b) Crushed Surfacing Materials: $M_r = 28,000$ psi
 - c) Subgrade Soil: The M_r is based on actual field or laboratory tests. The M_r value used in the pavement design is not to exceed 15,000 psi.

Resilient modulus values for the subgrade soil shall be determined by Laboratory M_r tests or Falling Weight Deflectometer tests (FWD) performed in situ or default M_r values based on soil classification per the Unified Soil Classification System (USCS). The soil classification shall be based on laboratory testing of representative samples of subgrade soil.

USCS soil types shall be determined per ASTM D 2487. Default M_r values based on the USCS are as follows:

Class	M_r (psi)	USCS Soil Type
A	15,000	GW, GP, GW-GM, GP-GM
B	12,500	GM, SW, SP
C	10,000	SW-SM, SP-SM, SM ¹ ML ¹
D	7,500	GW-GC, GP-GC, SW-SC, SP-SC, SM ² ML ²
E	2,500	GC, GC-GM, SC, SC-SM, CL, CL-ML
F	Special Design ³	MH, CH, OL, OH, Peat

⁽¹⁾ Nonplastic

⁽²⁾ Plastic

⁽³⁾ Class F soils require a special design required to stabilize the subgrade and will be subject to review and approval by the County Road Engineer.

Notes:

1. Pavement design sections shall not be less than those required for residential streets.
2. The roadway section for a multi-family residential development can be design and constructed to meet the requirements of a residential roadway section.

4.06 Materials and Lay-Down Procedures:

Materials and lay-down procedures shall be in accordance with WSDOT/APWA Standard Specifications and the following requirements:

- A. Prior to placement of the curb, gutter, and pavement section, a proof roll shall be performed to confirm the subgrade is firm and unyielding. A single or dual axle dump truck, loaded to a minimum 90 percent maximum gross weight

capacity, shall be used to perform the proof roll. The subgrade must comply with the requirements of Section 8.03 and 9.04 of these Standards.

- B. During surfacing activities utility covers in roadway shall be adjusted in accordance with Section 8.05.
- C. Asphalt pavers shall be self contained, power-propelled units. Truck mounted pavers are not considered self-propelled. Truck mounted pavers shall only be used for paving of irregularly shaped or minor areas as approved by the County Road Engineer, or as follows:
 - a) Pavement widths less than 8 feet; and
 - b) Pavement lengths less than 150 feet
- D. Hot mix asphalt (HMA) for wearing course shall not be placed on any traveled way between October 1 of any year and April 1 of the following year without written approval from the Inspector. Asphalt for prime coat shall not be applied when the ground temperature is lower than fifty degrees Fahrenheit without written approval from the Inspector. When discharged the temperature of the HMA shall not exceed the maximum temperature recommended by the asphalt binder manufacturer. For surface temperature limitations, see Section 5-04.3(16) of the WSDOT/APWA Standard Specifications. Each truckload shall be covered with a suitable tarpaulin while in transit to prevent unnecessary heat loss.
- E. Unfavorable Weather

Asphalt shall not be applied to wet material. Asphalt shall not be applied during rainfall or before any imminent storms that might damage the construction. The Inspector will have the discretion as to whether the surface and materials are dry enough to proceed with construction.

4.07 Asphalt Surfacing Repairs:

When repairing shallow holes and gouges in asphalt, the surface must be thoroughly cleaned. The bottom and edges of the hole/gouge shall be swabbed with asphalt tack. Premixed hot material shall then be placed and thoroughly tamped or rolled. The edges shall then be sealed in accordance with Section 5-04.3(19) of the WSDOT/APWA Standard Specifications.

For failures or holes/gouges exceeding 1" in depth, the minimum repair area shall be three feet beyond the perimeter. The existing pavement shall be sawcut or removed by a pavement grinder. Asphalt for tack coat shall be applied to all surfaces of existing pavement in the repair area. Placement of HMA shall be placed in lifts of not greater than 0.35- foot compacted depth and shall be thoroughly compacted by mechanical tamper or roller. Edges shall be sealed in accordance with Section 5-04.3(19) of the WSDOT/APWA Standard Specifications.

4.08 Pavement Markings, Markers, and Pavement Tapers

Pavement markings and raised pavement markers shall be used to delineate channelization, transit lanes, bus zones, lane endings, crosswalks and longitudinal lines to control or guide all users of the roadway system and shall conform to figures 4-001 through 4-009. When removal of existing pavement markings are required a full-width overlay must be performed to remove any reflections of the old markings. Channelization plans and crosswalk locations shall be approved by the Traffic Engineer. Channelization plans of intersections shall be provided at a 1"= 20' scale. Channelization plans of connecting roadways may be 1"= 40' scale.

Channelization shall be required when through traffic is diverted around a lane or obstacle; when connecting full-width streets with different cross sections; and when extending an existing street with a new cross section different than the existing one. The channelization shall provide shift tapers equal in length to the posted speed limit times the distance in feet of diversion from the road centerline or the original alignment of travel, or the offset distance, as applicable. Channelization shall also be required to redirect traffic back to its original alignment.

Pavement markings for channelization shall be reflectorized hot or cold applied plastic. Extruded or sprayed markings shall be dressed with glass beads for initial reflectance. All materials shall have beads throughout to maintain reflectance as the material wears.

Where pavement widening less than 300 feet in length is abruptly ended and edge lines do not direct traffic to through lanes, Type 2 lane markers shall be installed at 10-foot centers near the end of the paved area at a 10:1 taper.

Crosswalks shall be installed at all intersections controlled by traffic signals and other areas approved by the Traffic Engineer. Crosswalks shall consist of pairs of longitudinal lines 8 inches wide by 10 feet long and with an eight-inch separation. A pair of these lines shall be installed in line with each lane line and at the midpoint of each lane.

All pavement markings shall be laid out with spray paint and approved by the County Traffic Engineer before they are installed. Approval shall require advance notice of three working days to have field layout approved by the County Traffic Engineer or to make arrangements to meet the County Traffic Engineer or his designee on site during the installation.

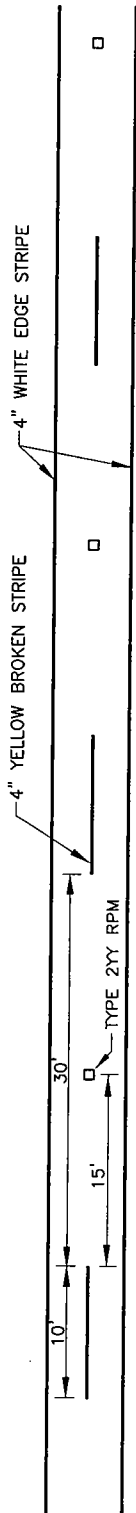

SINGLE LANE TWO-WAY TRAFFIC

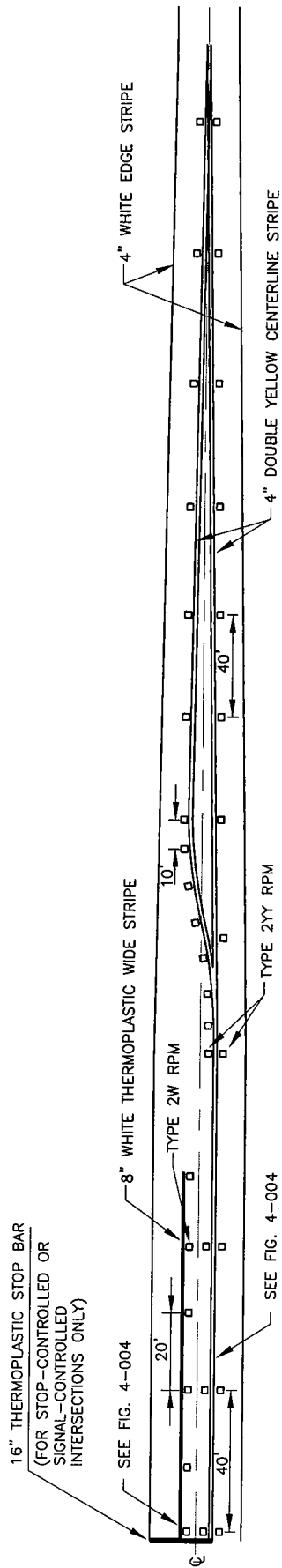

LEFT TURN POCKET AND MEDIAN

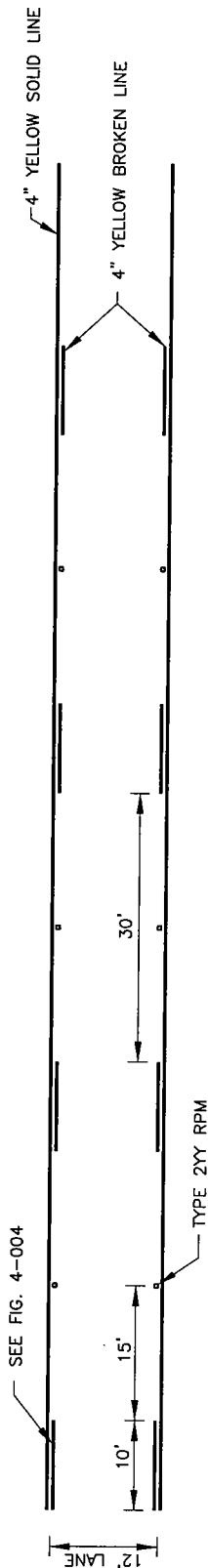

TWO-WAY LEFT TURN LANE

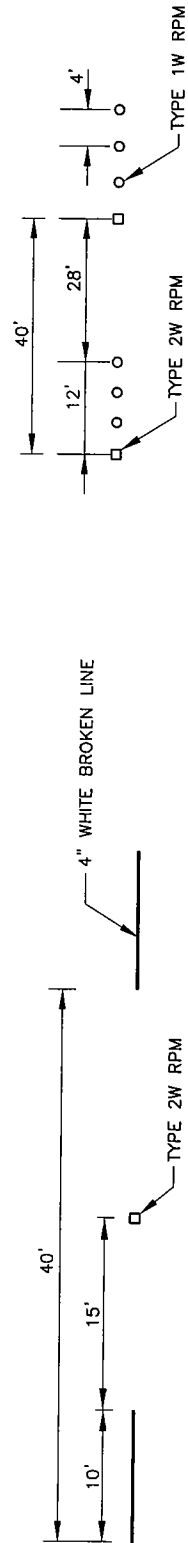

**TRAVEL DIRECTION
ALTERNATE LANE MARKINGS**

LANE SEPARATION

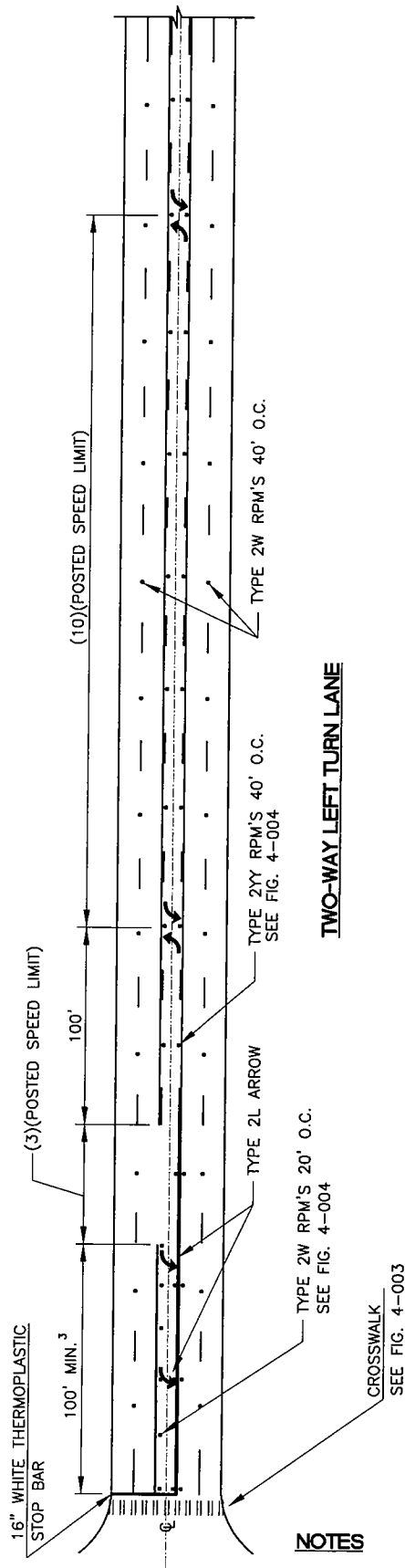
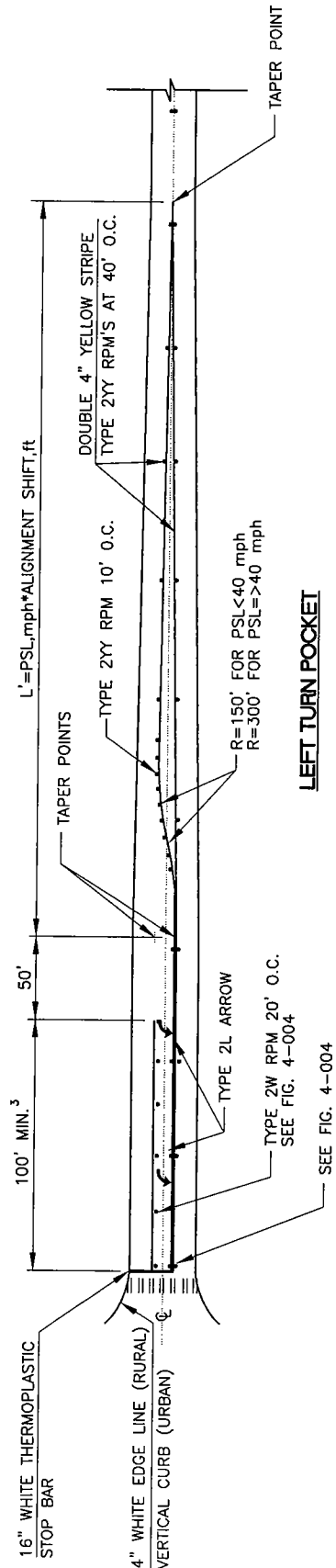

NOTES

1. QUEUE LENGTHS SHOULD BE SUPPORTED BY TRAFFIC ANALYSIS.
 2. MAXIMUM 15 FT. AT SIGNALIZED INTERSECTIONS.
 3. RAISED ISLANDS AND CROSSWALKS ARE OPTIONAL.
- PSL = POSTED SPEED LIMIT

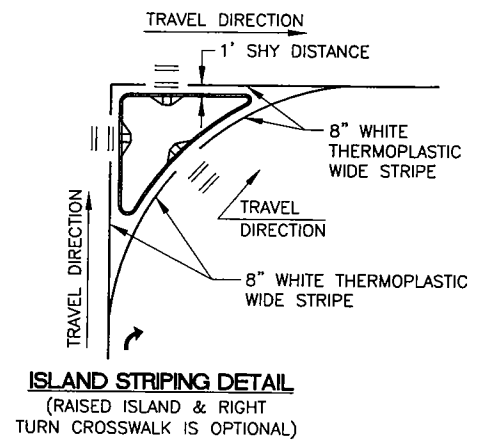
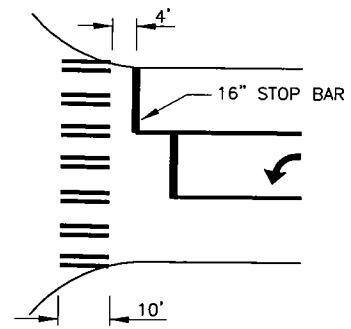

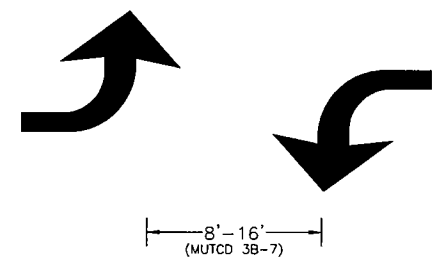
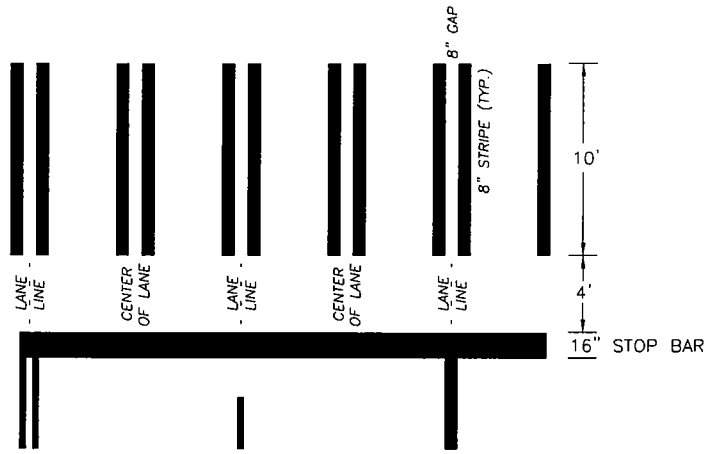
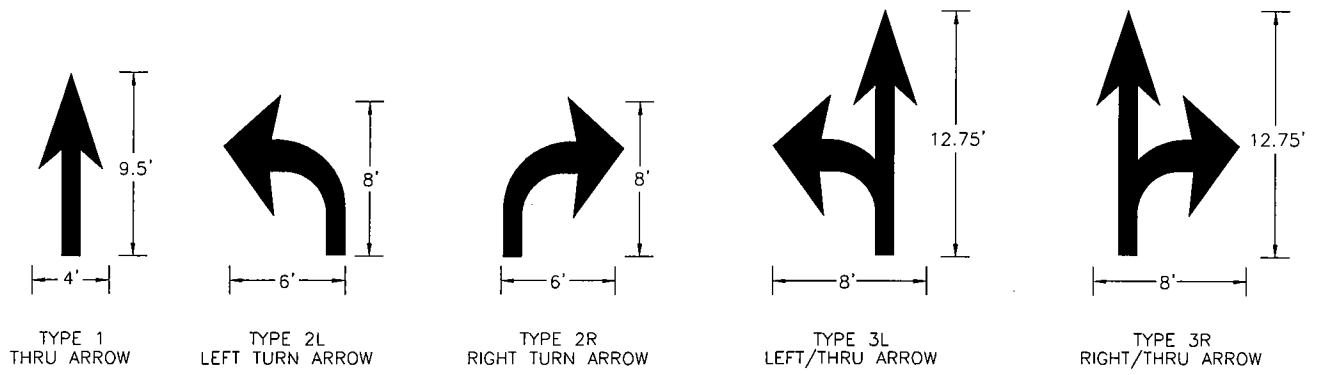

THERMOPLASTIC

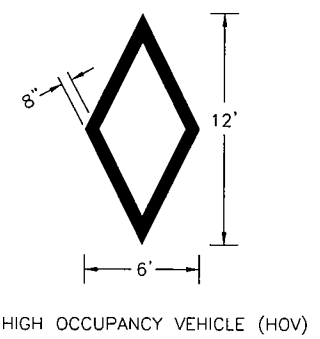
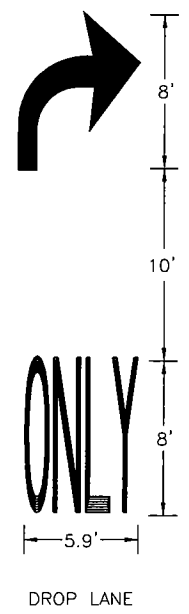
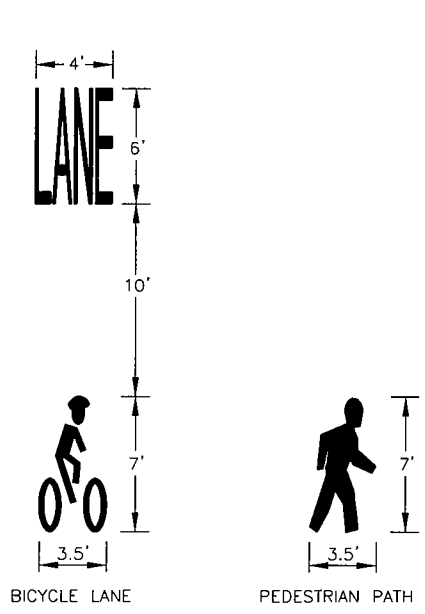

PAINTED

THERMOPLASTIC

PAVEMENT SYMBOLS

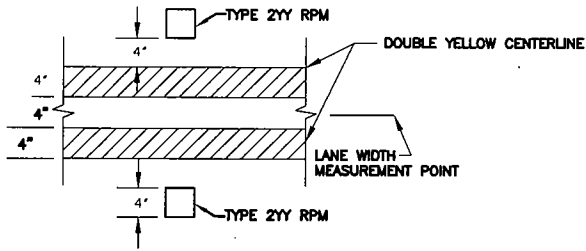

CENTERLINE

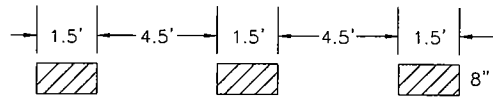

LANE EXTENSION STRIPE

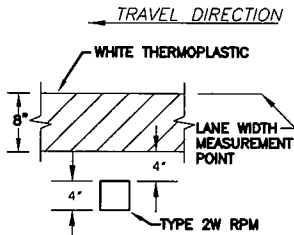

WIDE STRIPE

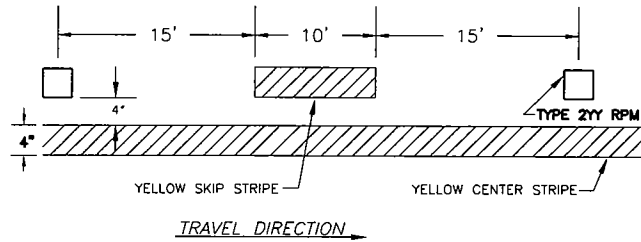

TWO-WAY LEFT TURN LANE

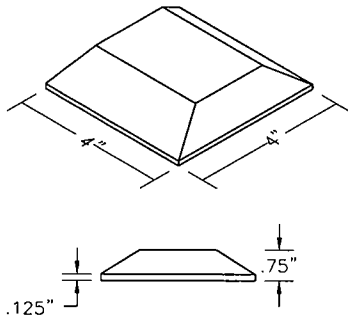

TYPE 2 RPM

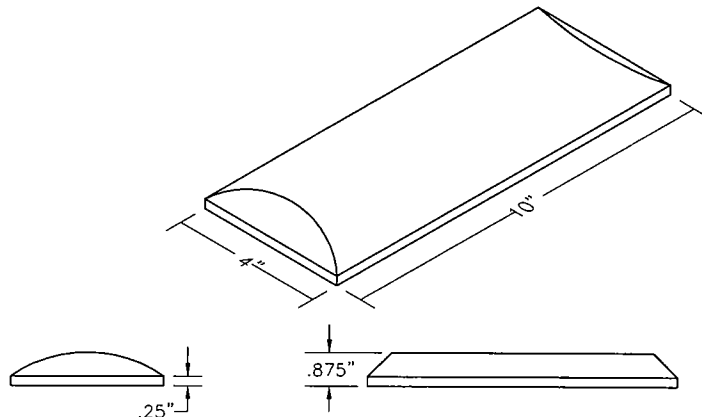

TYPE 3 RPM

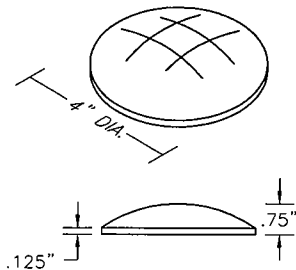

TYPE 1 RPM

RAISED PAVEMENT MARKER COLORS	
TYPE 1W	NONREFLECTORIZED WHITE
TYPE 1Y	NONREFLECTORIZED YELLOW
TYPE 2W	REFLECTORIZED WHITE - ONE SIDE ONLY
TYPE 2Y	REFLECTORIZED YELLOW - ONE SIDE ONLY
TYPE 2YY	REFLECTORIZED YELLOW - BOTH SIDES

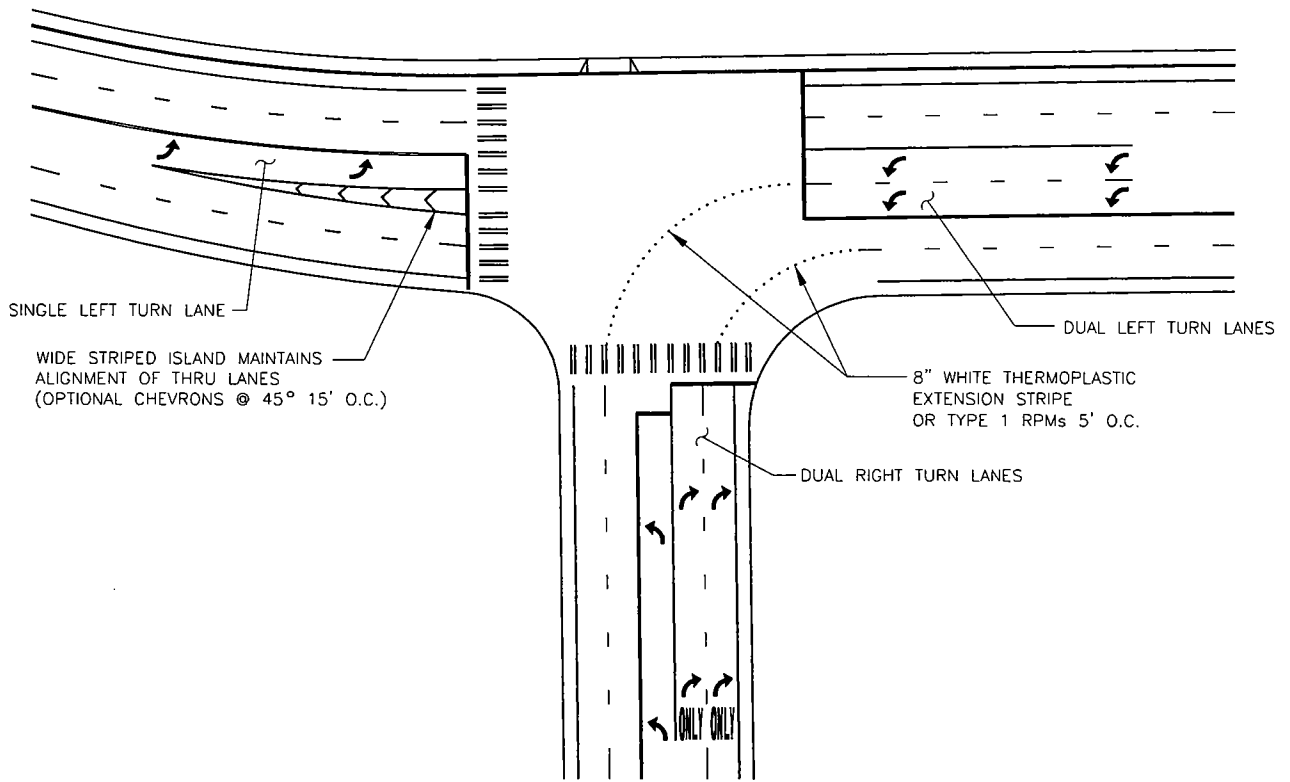

CROSS STREET INTERSECTION

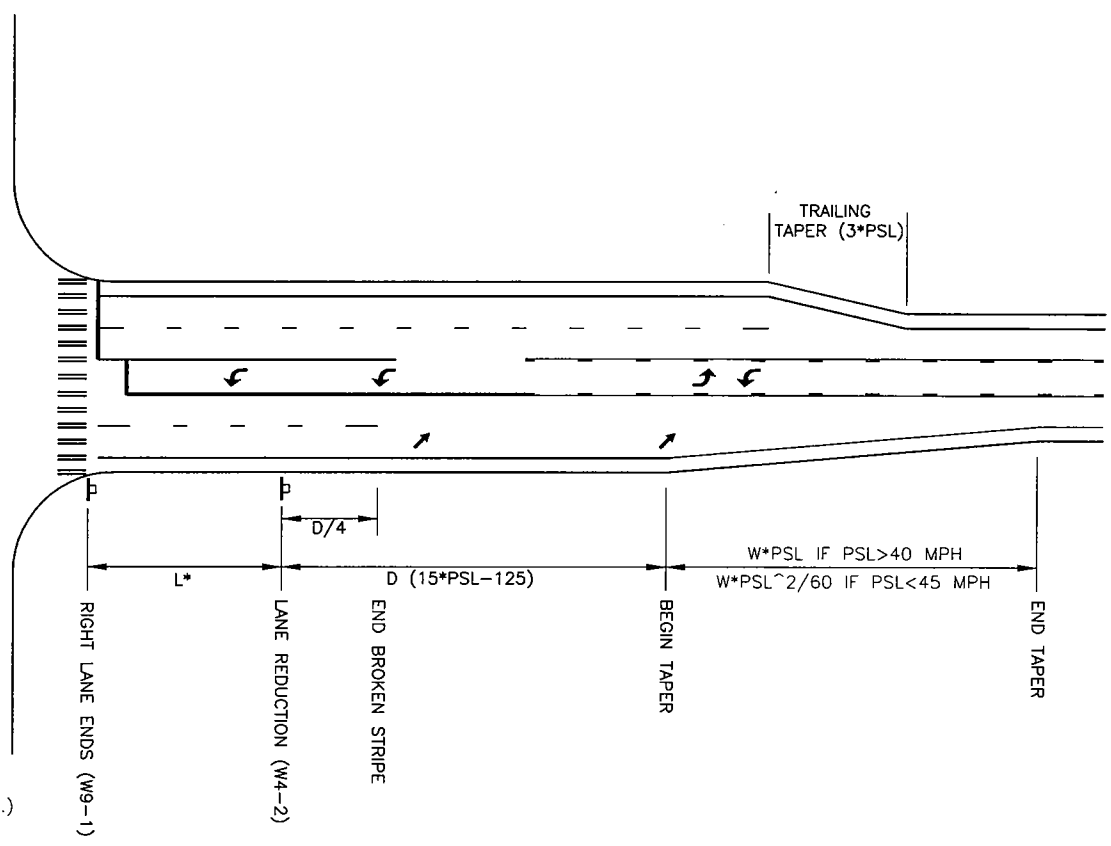

**SIGN SPACING*

L, ft	PSL, MPH
175'	35 MPH (Min.)
250'	40 MPH
300'	45 MPH
400'	50 MPH

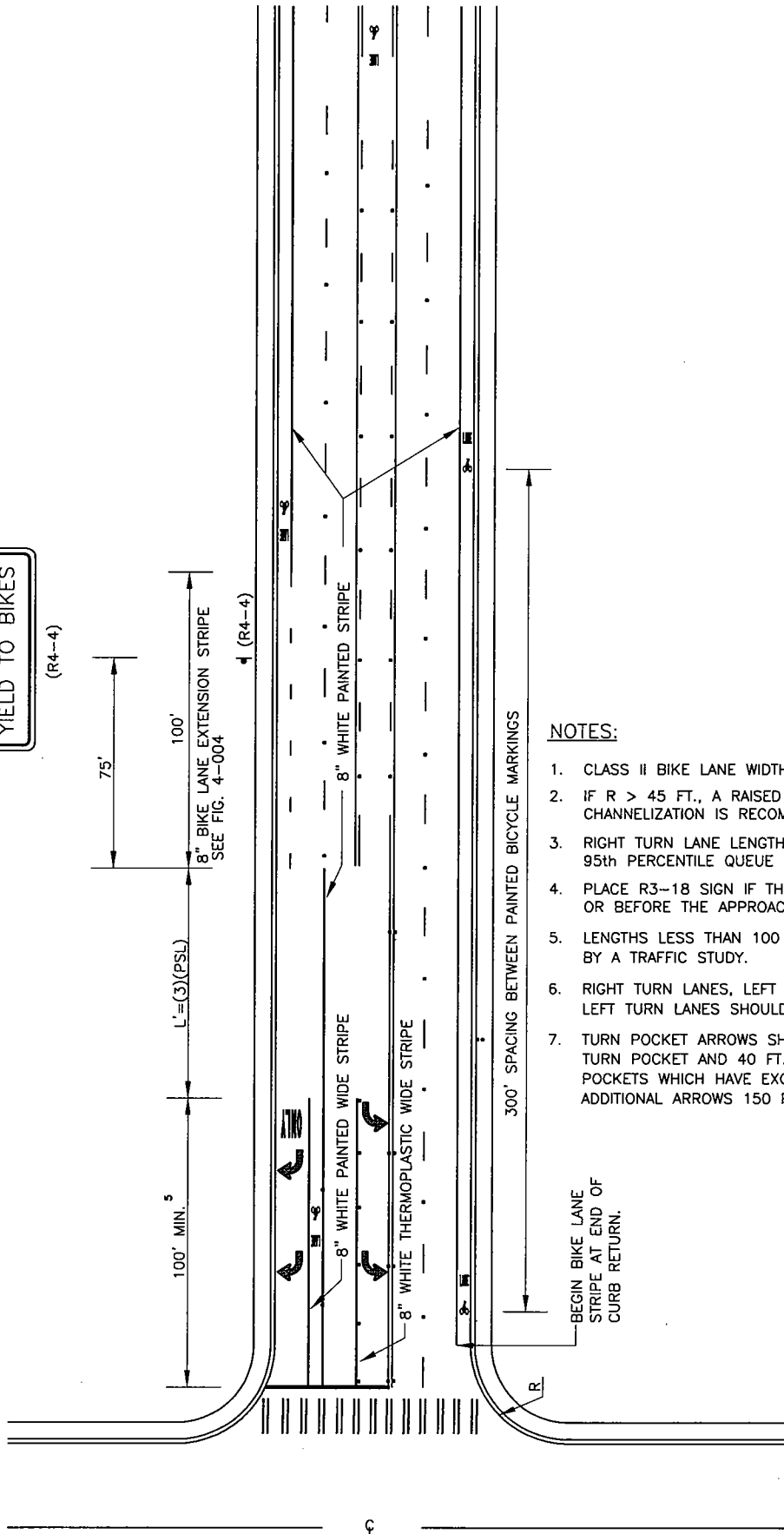
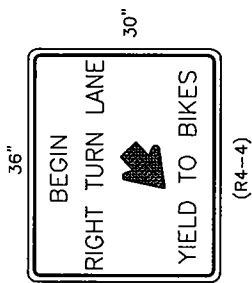

NOTES:

1. CLASS II BIKE LANE WIDTH MUST BE 5 FT.
2. IF $R > 45$ FT., A RAISED ISLAND FOR RIGHT TURN CHANNELIZATION IS RECOMMENDED.
3. RIGHT TURN LANE LENGTH DETERMINED BY 95th PERCENTILE QUEUE LENGTH VALUE.
4. PLACE R3-18 SIGN IF THE BIKE LANE TERMINATES AT OR BEFORE THE APPROACHING INTERSECTION.
5. LENGTHS LESS THAN 100 FT. MAY BE JUSTIFIED BY A TRAFFIC STUDY.
6. RIGHT TURN LANES, LEFT TURN LANES, AND TWO-WAY LEFT TURN LANES SHOULD BE 12 FT. IN WIDTH.
7. TURN POCKET ARROWS SHALL BEGIN AT THE START OF THE TURN POCKET AND 40 FT. BEHIND THE STOP BAR IF NEEDED, POCKETS WHICH HAVE EXCESSIVE LENGTHS MAY REQUIRE ADDITIONAL ARROWS 150 FT. APART.

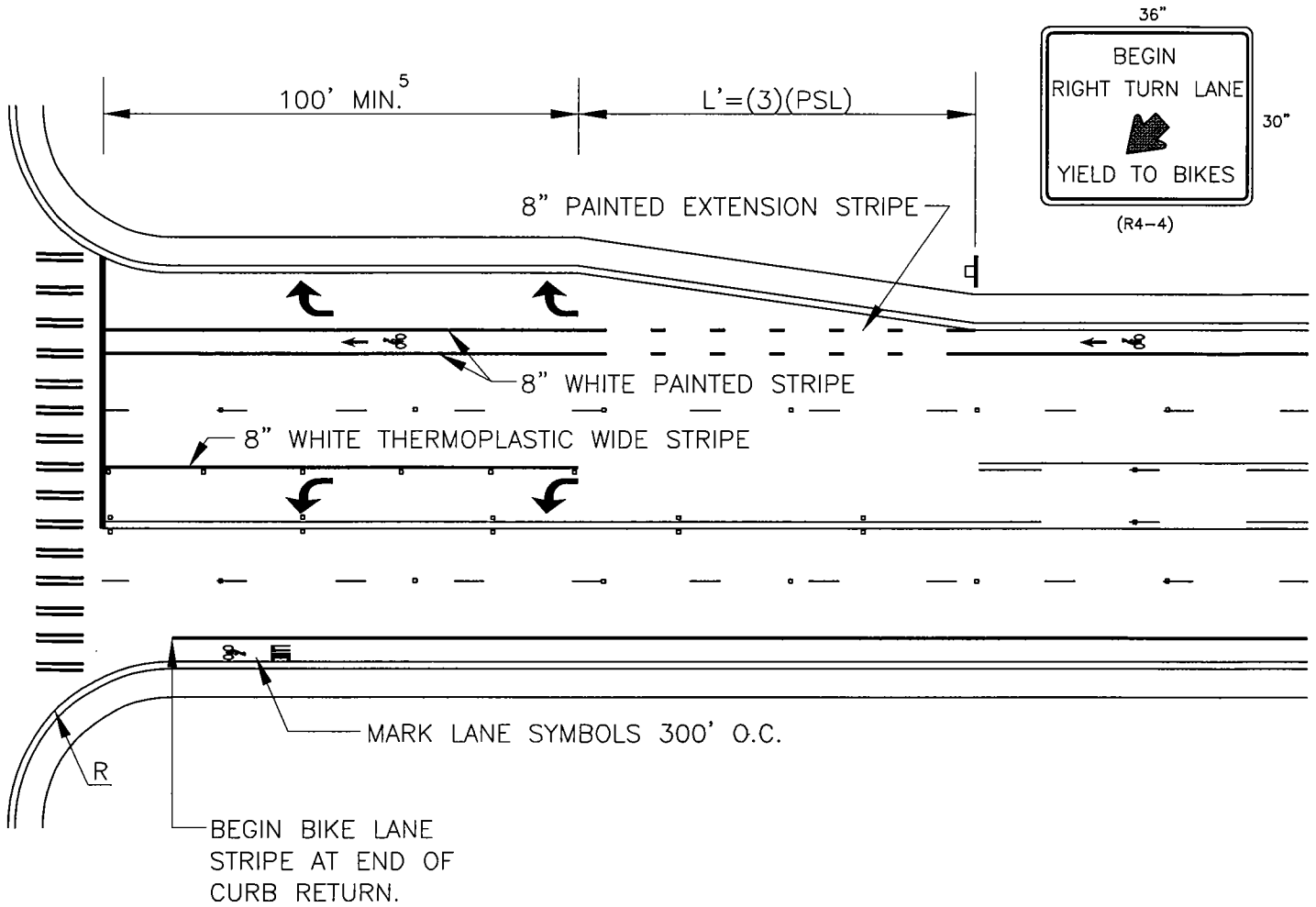

NOTES:

1. CLASS II BIKE LANE WIDTH IS 5 FT.
2. IF $R > 45$ FT., A RAISED ISLAND FOR RIGHT TURN CHANNELIZATION IS RECOMMENDED.
3. RIGHT TURN QUEUE LENGTH DETERMINED BY 95TH PERCENTILE VALUE.
4. PLACE R3-18 SIGN IF THE BIKE LANE TERMINATES AT OR BEFORE THE APPROACHING INTERSECTION.
5. LENGTHS SHORTER THAN 100 FT. MAY BE JUSTIFIED WITH TRAFFIC STUDIES.
6. RIGHT TURN LANES, LEFT TURN LANES, AND TWO-WAY LEFT TURN LANES SHOULD ALL BE 12 FT. IN WIDTH.

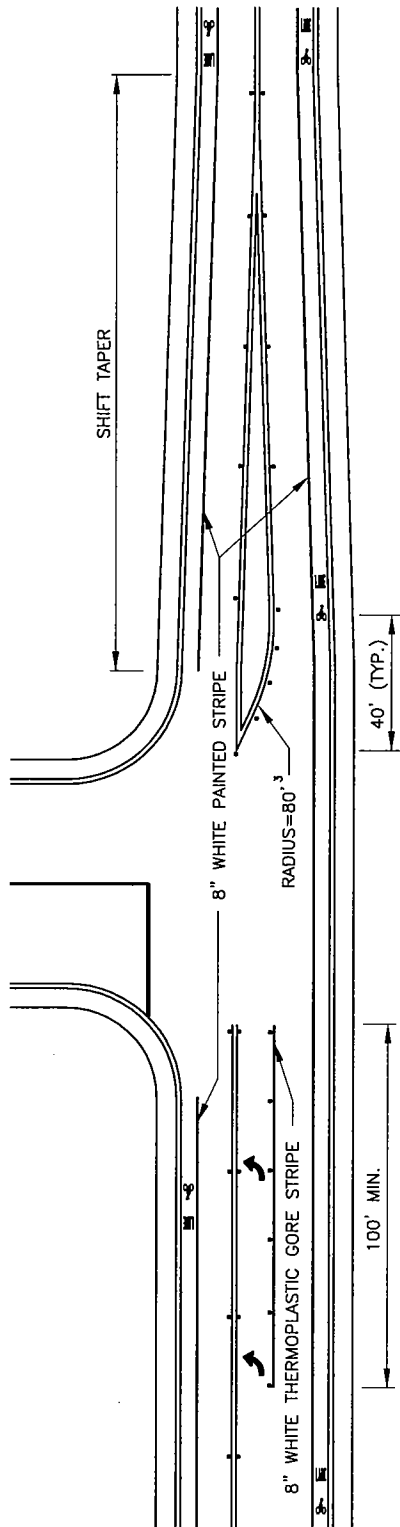

LEFT TURN WITH MEDIAN ISLAND

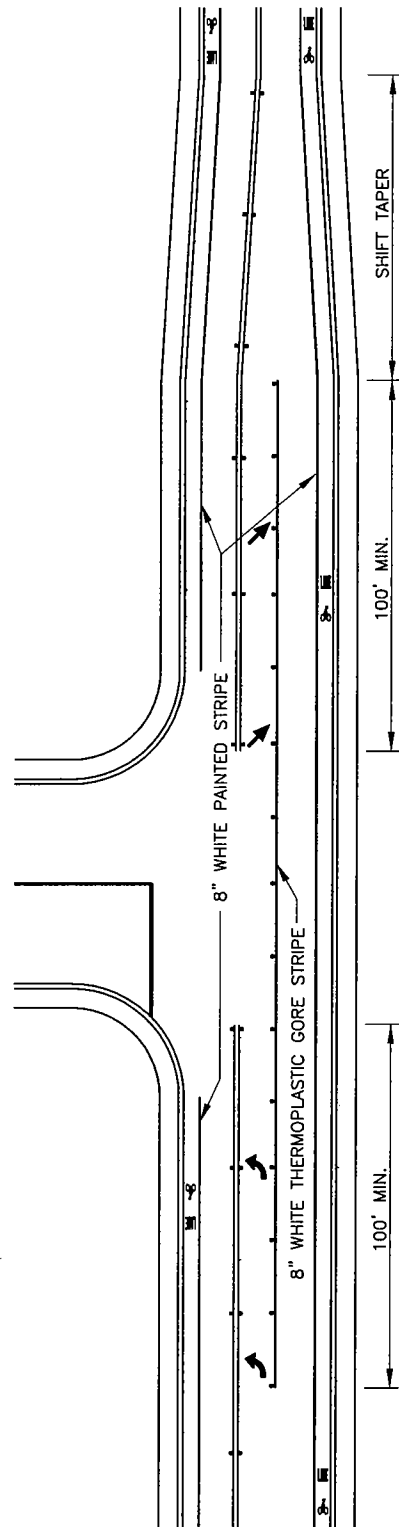

LEFT TURN REFUGE LANE

NOTES:

1. TYPE 2L ARROW SPACING: BEGINNING OF THE TURN POCKET AND 40 FT. FROM THE END OF THE POCKET.
2. TYPE 1 ARROW SPACING: END OF THE REFUGE LANE AND 40 FT. FROM THE BEGINNING OF THE REFUGE LANE.
3. RADIUS SHOULD ACCOMMODATE LEFT TURNING VEHICLES.

FOR USE ON 3 OR 5-LANE ROADWAYS

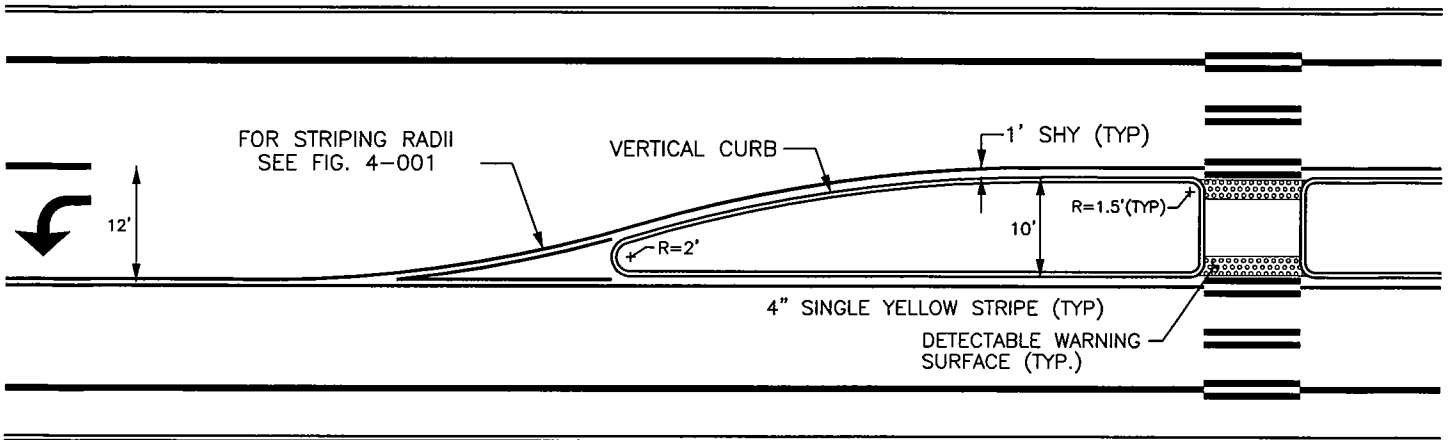

LEADING END

PEDESTRIAN REFUGE
AT MIDBLOCK

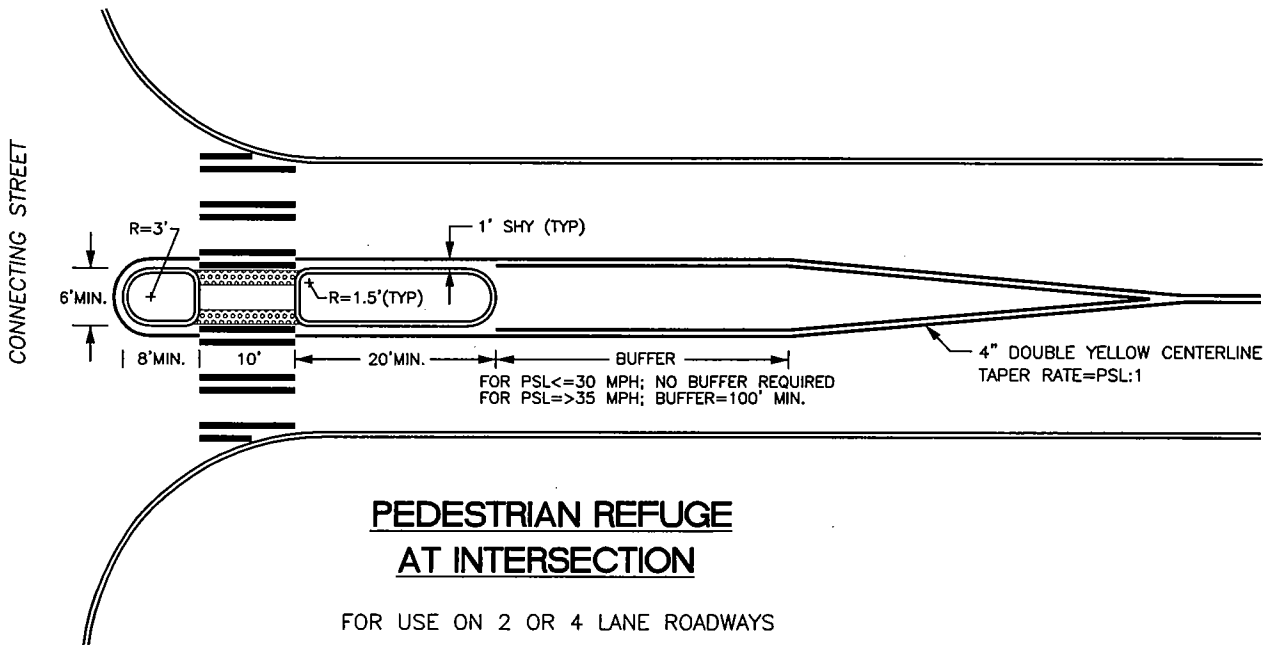

PEDESTRIAN REFUGE
AT INTERSECTION

FOR USE ON 2 OR 4 LANE ROADWAYS

NOTES:

1. RAISED MEDIAN ISLANDS SHALL BE FULLY ILLUMINATED.
2. LANDSCAPING FOR ISLANDS SHALL MAINTAIN SIGHTLINES FOR ALL VEHICLE MOVEMENTS.
3. NOSE OF ISLAND AT INTERSECTION SHOULD ALLOW FOR TRUCK TURNING.
4. CROSSWALK MARKINGS ARE REQUIRED IF NEAR EDGE OF CROSSWALK IS FURTHER THAN 10 FT. FROM EDGE OF CONNECTING STREET.

CHAPTER 5. ROADSIDE FEATURES

5.01 Rock Facings

A. Rock facings may be used for the erosion protection of cut or fill embankments up to a maximum height of 8 feet above the keyway in stable soil conditions, which will result in no significant foundation settlement or outward thrust upon the walls. See figures 5-003 through 5-006. For heights over 8 feet above the keyway or when soil is unstable, a structural wall of acceptable design stamped by a licensed structural engineer is required. As an exception, rock-facing heights may exceed 8 feet to a limited extent based on favorable soils analyses and a design by a geotechnical engineer or other professional engineer qualified in rock wall design, subject to approval by the County Road Engineer. Terracing of rockeries subject to approval by the County Road Engineer. Terracing shall not surcharge lower rockeries.

B. Materials

1. Size categories shall include:

Two-man rock	200 to 700 lb.	18 to 28in.
Three-man rock	701 to 2,000 lb.	28 to 36 in.
Four-man rock	2,001 to 4,000 lb.	36 to 48 in.

Four-man rocks shall be used for bottom course rock in all rock facings over 6 feet in height.

2. The rock material shall be as nearly rectangular as possible. No stone shall be used which does not extend through the wall. The quarried trap rock shall be hard, sound, durable and free from weathered portions, seams, cracks and other defects. Rock quality shall meet all the test requirements of Section 9-13, "Riprap, Quarry Spalls, and Slope Protection" of the current Washington State Department of Transportation (WSDOT) Standard Specifications."

C. Keyway

A keyway consisting of a shallow trench of minimum 12-inch depth shall be constructed the full rockery length, and slightly inclined towards the face being protected. It shall be excavated the full rockery width including the rock filter layer. The keyway subgrade shall be firm and acceptable to the County Road Engineer. See figures 5-003 through 5-006.

D. Underdrains

1. A minimum 6inch diameter perforated or slotted drainpipe shall be placed in a shallow excavated trench located along the inside edge of the keyway. The pipe shall be bedded on "Gravel Backfill for Drains" (WSDOT/APWA 9-

03.12(4)). The pipe shall be completely surrounded and covered with the gravel backfill to a minimum height of 18 inches from the bottom of the trench. Geotextile for underground shall surround the gravel backfill and shall have a minimum one-foot overlap along the top surface of the gravel. This requirement for geotextile may be waived by the County Road Engineer or Development Engineer, if shown that soils and water conditions make it unnecessary. See figures 5-003 through 5-006.

2. The perforated pipe shall be connected to the storm drain system or to an acceptable outfall. Cleanouts must be provided at main angle points.

E. Rock Selection and Placement:

Rock selection and placement shall be such that there will be minimum voids and, in the exposed face, no open voids over 6 inches across in any direction. The final course shall have a continuous appearance and be placed to minimize erosion of the backfill material. The larger rocks shall be placed at the base of the facing so that it will be stable and have a stable appearance. The rocks shall be placed in a manner such that the longitudinal axis of the rock shall be at right angles to the face. The rocks shall have all inclined faces sloping to the back of the facing. Each course of rocks shall be seated as tightly and evenly as possible on the course beneath. The rocks shall be placed so that there are no continuous joint planes either horizontally or vertically. After setting each course of rock, all voids between the rocks shall be chinked on the back with quarry rock to eliminate any void sufficient to pass a 2-inch square probe. See figures 5-003 through 5-006.

F. Rock Filter Layers:

The rock filter layer shall consist of quarry spalls with a maximum size of 4 inches and a minimum size of 2 inches. This material shall be placed to a 12 inch minimum thickness between the entire facing and the cut or fill material. The backfill material shall be placed in lifts to an elevation approximately 6 inches below the top of each course of rocks as they are placed, until the uppermost course is placed. Any backfill material on the bearing surface of one rock course shall be removed before setting the next course.

G. Fill Rockery Facing Supporting Roadway Embankment:

Embankment behind rockeries exceeding 4 feet in height above the keyway shall be reinforced with a geosynthetic fabric or geogrid specifically manufactured for soil reinforcement, designed on a project-specific basis by a qualified engineer. See figures 5-004 and 5-006.

H. Sidewalks Above Rockery Facings:

When a sidewalk is to be built over a rock facing, the top of the facing shall be sealed and leveled with a cap constructed of cement concrete Class 4000 in accordance with the applicable provisions of Section 6-02 of the WSDOT/APWA Standard Specifications, but with reduced water content resulting in slump of not over 2 inches. See figure 5-005.

I. Fences and Handrails:

A chain link fence or metal handrail shall be installed when rockery is 18 inches or greater in height or as required by the County Road Engineer or Development Engineer. See figures 5-003 through 5-005, 5-007 and 5-008.

5.02 Side Slopes

- A. Side slopes shall generally be constructed no steeper than 2:1 on both fill slopes and cut slopes. Steeper slopes may be approved by the County Road Engineer upon showing that the steeper slopes, based on soil analyses, will be stable. Side slopes on projects funded by federal grants shall be constructed in conformance with Local Agency Guidelines.
- B. Side slopes shall be stabilized by grass sod or seeding or by other planting or surfacing materials acceptable to the County Road Engineer.

5.03 Street Trees and Landscaping

- A. Street trees and landscaping should be incorporated into the design of road improvements for all classifications of roads. Such landscaping in the right-of-way, by applicants/developers, shall be coordinated with off-street landscaping required on applicant' property under the provisions of King County Code Title 21A.
- B. The preservation of existing trees and vegetation is strongly encouraged, where feasible. Placement of new trees and landscaping shall be compatible with road features and natural elements of the environment. In particular, mature tree heights and spacing shall not conflict unduly with overhead utilities or impact line of sight. Natural root growth shall not impact sidewalks, curbs and underground utilities. Street tree planting shall conform reasonably to the standards in the drawings contained herein.
- C. The preference in approving the planting of trees within the public right-of-way shall be for planting at back of walk. Planting strips shall be approved by the County Road Engineer only as part of a landscape plan in which the standards have duly been considered, including but not limited to compatibility with above and below ground utilities, size and growth habit, traffic safety, and a lifetime maintenance commitment for the caring of and the repairing of associated damages to sidewalks, curbs & gutters, drainage, etc.
- D. When the County Road Engineer allows planting strips to be located adjacent to the curb they shall meet the following requirements:
1. The minimum width from back of curb to sidewalk shall be 4 feet on residential streets and 5 feet on arterials.
 2. Minimum distance from the center of any tree to the face of curb shall be 3 feet.

3. Only deciduous trees and shrubs that mature less than 24 inches in height, such as ground covers or grasses shall be planted in the planting strips.
 4. All trees shall be staked so as to be parallel to the walk and curbs. All tree planting shall include the installation of an approved root barrier adjacent to walks and curbs for each tree, unless otherwise approved by the County Road Engineer.
 5. Location of trees shall take into consideration fixed objects so as not to obstruct sight distance, bus shelters, street signs, luminaries, mailboxes, utility boxes and other fixtures.
 6. The top 12 inches of soil within the entire planting strip shall be removed prior to planting and replaced with appropriate topsoil conducive to good plant growth. Provision for drainage and watering shall be considered required relative to the plant species approved. Permanent irrigation systems are not allowed in the right-of-way. The applicant/developer shall ensure that temporary irrigation systems are either removed or properly disconnected to prevent water leakage prior to final roadway acceptance by the County.
 7. The County Road Engineer may restrict the use of plant materials in the right-of-way where sight distance, traffic safety, pedestrian conflicts and maintenance issues are of concern.
- E. Minimum setback of trees in right-of way from fixed objects shall meet the following criteria, as shown in figure 5-009:
1. 50 feet from intersection vertical curb line
 2. 20 feet from luminaries and utility poles
 3. 20 feet from signs
 4. 15 feet from bus shelters,
 5. 10 feet from driveways
 6. 10 feet from utility vaults/boxes
 7. 10 feet back of sidewalk for all evergreen trees
 8. 5 feet from hydrants
 9. 2 feet from back of sidewalk for all deciduous trees
 10. Outside identified sight distance restricted areas
- F. All trees adjacent to walkways shall have a 7-foot minimum branching height at time of planting. This may be reduced if trees are more than 5 feet back of sidewalk. Minimum height clearance of existing trees adjacent to new road shall be 15 feet above the finished roadway grade.
- G. Commercial root barriers shall be required for all trees planted back of sidewalks and curbs. See figure 5-011.

- H. The use of tree blockouts, figure 5-010, shall meet ADA standards for minimum sidewalk clearance of 36 inches. Tree grates that meet ADA standards may be considered for meeting the minimum sidewalk width.
- I. Trees planted within the King County clear zone shall have a breakaway mature trunk diameter of four inches or less. Trees with mature trunk diameters of greater than 4 inches shall be located outside the clear zone. King County clear zone setbacks for larger diameter trees shall meet the requirements of Section 5.11. See figure 5-010.
- J. Traffic islands and circles may be paved or planted with low shrubs (24" mature height or less) and ground covers, if long-term maintenance is provided and they have no traffic or pedestrian safety issues. These planter islands shall be at least 9 feet wide from curb face to face. The first 20 feet of these islands may be planted with low shrubs and ground covers. Deciduous trees may be used if set back a minimum of 20 feet from the front of the island and evergreens at a minimum of 30 feet.
- K. When rockeries or retaining walls are proposed adjacent to sidewalks, they shall generally be placed as close to the right-of-way line as practicable and a minimum of 10 feet from the edge of the traveled way or edge line and in accordance with figure 5-001.
- L. Planting of street trees within the right-of-way shall generally be in accordance with the list herein. Alternative tree plantings, not on this list, may be used subject to review and approval by the County Road Engineer.
- M. Deciduous trees identified as not acceptable in planting strips less than fifteen feet wide include, but not limited to; london plane, sycamore, sweetgum, soft maple, alder, boxelder, black locust willow species, oak, elm, mountain ash, cherry, cottonwood, lombardy poplar, yellow or tulip poplar, walnut, catalpa, paulownia, honeylocust, hawthorne, big leaf maple, madrona, fruit bearing trees or any other tree the department determines has potential to disrupt utilities or impact roadway improvements. See Water & Sewer Systems King County Code, Title 13.04.230.
- N. This tree list is a guide for selecting street trees for planting within the right-of-way and no preference is given by their order of listing. There may be other tree species and varieties not on this list that may be acceptable to the County Road Engineer. As a general rule of thumb, no trees that: bear fruit, have poisonous features or thorns, host disease, require special maintenance, cause damage to infrastructure or pose any health or safety risk to the general public will be approved for use as street trees. The approved street trees are as follows:

SMALL / MEDIUM TREES:

Small/medium trees are acceptable for use in planting strips 4 feet or wider. Use of a root barrier required. (Maintenance of some species listed is required to maintain clearance under lower power lines).

Acer campestre / Hedge Maple
 Acer campestre 'Evelyn' / Queen Elizabeth Maple
 Acer ginnala / Amur Maple
 Acer glabrum / Rocky Mountain Maple
 Amelanchier x grandiflora 'Autumn Brilliance' / Serviceberry
 Cercis canadensis / Eastern Redbud
 Cornus kousa / Chinese or Korean Dogwood
 Cornus nuttallii / Pacific Dogwood
 Fraxinus pennsylvanica 'Johnson' / Leprechaun Ash
 Malus 'Golden Raindrops' / Flowering Crabapple (little to non-fruiting)
 Malus 'Spring Snow' / Flowering Crabapple (non-fruiting)
 Malus tschonoskii / Flowering Crabapple (sparse to non-fruiting)
 Pyrus calleryana 'Aristocrat' / Aristocrat Flowering Pear
 Pyrus calleryana 'Autumn Blaze' / Flowering Pear
 Pyrus calleryana 'Capital' / Capital Flowering Pear
 Pyrus calleryana 'Chanticleer' / Flowering Pear
 Pyrus calleryana 'Cleveland Select' / Cleveland Flowering Pear
 Pyrus calleryana 'Redspire' / Redspire Flowering Pear
 Oxydendron arboreum / Sourwood
 Stewartia koreana / Korean Stewartia
 Stewartia mondelpha / Tall Stewartia

MEDIUM / LARGE TREES:

Acceptable for use in planting strips 6 feet or wider. Use of a root barrier required. (Not for use under power line locations).

Acer rubrum 'Armstrong' / Armstrong Maple
 Acer rubrum 'Autumn Flame' / Autumn Flame Maple
 Acer rubrum 'Bowhall' / Bowhall Maple
 Acer rubrum 'October Glory' / October Glory Maple
 Acer rubrum 'Scarsen' / Scarlet Maple
 Acer rubrum 'Red Sunset' / Red Sunset Maple
 Betulus jacquemontii, / Jacquemonti Birch
 Carpinus betulus 'Fastigiata' / European Hornbeam
 Fraxinus oxycarpa 'Raywood' / Raywood Ash
 Fraxinus latifolia / Oregon Ash
 Fraxinus pennsylvanica 'Patmore' / Patmore Ash
 Fraxinus pennsylvanica 'Summit' / Summit Ash
 Fraxinus pennsylvanica 'Urbanite' / Urbanite Ash
 Ginkgo biloba 'Autumn Gold' / Autumn Gold Ginko (males only)
 Ginkgo biloba 'Princeton Sentry' / Princeton Sentry Ginko (males only)
 Halesia monticola 'Silverbell' / Mountain Silverbell
 Robinia x ambigua 'Idahoensis' / Pink Idaho Locust

Tilia cordata / Little Leaf Linden
 Tilia cordata 'Greenspire' / Greenspire Linden
 Zelkova serrata 'Green Vase' / Green Vase Zelkova
 Zelkova serrata 'Village Green' / Village Green Zelkova

LARGER TREES:

Acceptable for use in planting strips that are 15 feet minimum, or when planted 10 feet back of sidewalk. Use of a root barrier is required unless waived by KCDOT. (Not for use under power line locations).

Acer saccharum 'Bonfire' / Bonfire Maple
 Acer saccharum 'Green Mountain' / Green Mountain Maple
 Acer saccharum 'Commemoration' / Commemoration Maple
 Betula 'Crimson Frost' / Crimson Frost Birch
 Betula nigra / River Birch
 Betula Papyrifera / Paper Birch
 Cercidiphyllum japonicum / Katsura
 Fagus sylvatica / Green Beech
 Fagus sylvatica 'Fastigiata' / Columnar Beech
 Fraxinus pennsylvanica 'Marshall' / Marshall Ash
 Prunus serrulata 'Kwanzan' / Kwanzan Cherry
 Prunus x yedoensis / Yoshino Cherry
 Prunus sargentii / Sargents Cherry
 Quercus coccinea / Scarlet Oak
 Quercus garryana / Oregon Post Oak
 Quercus kelloggii / California Black Oak
 Quercus robur / English Oak
 Quercus robur 'Fastigiata' / Skyrocket Oak
 Quercus robur 'Pyramied' / Skymaster Oak
 Umbellaria californica / California Bay Laurel

- O. All street tree plans shall duly consider the natural form, size, habits, (including trunk diameter growth), impact on current and future sight distance, disease resistance, hardiness, level of maintenance, etc. in selecting the appropriate tree(s).
- P. The preparation and planting of street trees is required to follow the general details, specifications and corresponding text contained within the adopted Standards. Alternative planting practices and emerging technologies that achieve the same intent of these requirements will be considered and may be approved during the review process.

5.04 Mail Boxes

- A. The responsibilities for location support structures, and installation of mailboxes in connection with the construction or reconstruction of County roads are as follows:

1. The County Road Engineer or Development Engineer will:
 - a. Require road improvement plans, whether for construction by the Department of Transportation or by a private builder, to show clearly the designated location or relocation of mailboxes, whether single or in clusters.
 - b. Require with this information any necessary widening or reconfiguration of sidewalks with suitable knockouts or open strips for mailbox posts or pedestal.
 - c. Require these plans to include a statement on the first sheet that mailbox locations as shown on these plans have been coordinated with the serving post office at (City/Community), Washington. This will be a prerequisite to plan approval.
 - d. Require construction of mailbox locations in accordance with these plans, through usual inspection and enforcement procedures.
2. The Postmaster or designated serving post office will:
 - a. Designate location and manner of grouping of mailboxes when so requested by the design agency. Note on the plans the type of mailbox delivery: NDCBU (Neighborhood Delivery and Collection Box Unit), or Rural type box. Authenticate by stamp or signature when these data have been correctly incorporated into the plans.
 - b. Do all necessary coordination with owners or residents involved to secure agreement as to mailbox location and to instruct them regarding mailbox installation. Actually install or relocate NDCBUs if these are the types of box to be used in the neighborhood.
3. Owners or residents served by mailboxes, at time of original installation, will:
 - a. If using individual mailboxes, clustered or separate, install and thereafter maintain their own mailboxes as instructed by the post office.
 - b. If NDCBU delivery, rely on Post Office to provide and maintain NDCBUs.
4. Builders or their contractors shall:
 - a. Where there are existing mailboxes and no plans to replace them with NDCBUs:

When it becomes necessary to remove or otherwise disturb existing mailboxes within the limits of any project, install the boxes temporarily in such a position that their function will not be impaired. After construction work has been completed, reinstall boxes at original locations or at new approved locations as indicated on the plans or as directed by the County Road Engineer or Development Engineer. Use only existing posts or materials except that any damage caused by the builder or his/her contractor is to be repaired at the expense of the builder.

- b. Where there are existing NDCBUs or plans to install NDCBUs:
Call on the Postmaster or designated serving post office to locate or relocate NDCBUs and make the necessary installation.

B. Installation methods are as follows:

1. Mailboxes, in the general case, shall be set in accordance with figures 5-014, 5-015, 5-016, or 5-017. Boxes shall be clustered together when practical and when reasonably convenient to the houses served.
2. NDCBUs will be installed by the Postal Service generally in accordance with figure 5-017.
3. Non-yielding and non-breakaway mailbox structures will not be allowed within the clear zone. See Section 5.10 of these Standards. The use of concrete filled metal pipe for any mailboxes, or the use of horizontally mounted wooded members to support multiple mailboxes is expressly prohibited.

5.05 Street Illumination

Street illumination shall be provided on all urban and rural arterial roadways where there are three or more lanes of travel. Illumination will also be required as identifiers when a local road intersects an arterial. Illumination of roadways with turn channleziation will include all lane tapers.

The illumination system within the urban growth boundary shall be designed to provide a minimum of 1.2 foot-candles with an average-to-minimum uniformity ratio of 3:1, except at intersection where the system shall be designed to provide a minimum of 1.5 foot-candles with an average-to-minimum uniformity ratio of 3:1.

The illumination system outside the urban growth boundary shall be designed or provide a minimum of 1.0 foot-candles with an average-to-minimum uniformity ratio of 3:1, except at intersections where the system shall be designed to provide a minimum 1.5 foot-candles with an average-to-minimum uniformity ratio of 3:1.

When illumination is required for sag vertical curves the system shall be designed to provide a minimum of 0.4 foot-candles within the limits of the sag curve with a maximum average foot-candle value of 1.0. If an intersection is adjacent to the sag vertical curve, the illumination must include the intersection.

Steel poles shall be used for the street illumination system unless otherwise approved.

5.06 Survey Monuments

- A. Monuments shall be placed at all street intersections, boundary angle points, points of curves in streets and at such intermediate points as may be required by the County Road Engineer or Development Engineer.
- B. All existing monuments, which are disturbed, lost, or destroyed during construction or surveying, shall be replaced by a land surveyor registered in the State of Washington at the expense of the responsible applicant, contractor, builder, developer, or utility per RCW 58.09.130 and 58.04.015.

- C. Plat monumentation shall comply with these standards and in conformance with figure 5-019 and 5-020 on developments such as subdivisions, residential, commercial, binding site plans, or any other construction that establish new roadways or reconstruct existing roadways. Monuments shall be set along the center of the right of way at the PC's and PT'S of curves. When the PI of the curve falls within the paved area of the road, a PI monument may be set in lieu of setting the PC and PT.
- D. All lot and block corners shall be set with an iron pipe or steel reinforcing bar at least 24 inches in length within 90 days after recording of the plat. All lot corners shall be identified with the land surveyor's registration number.
- E. The monument case will be installed after the final course of surfacing has been placed on the road.

5.07 Roadway Barricades

Temporary and permanent barricades shall conform to the standards described in Section 6C-8 of the Manual on Uniform Traffic Control Devices (MUTCD) and figure 5-002.

- A. Type Type II or I barricades may be used when traffic is maintained through the area being constructed/reconstructed.
- B. Type III barricades shall be used when roadways and/or proposed future roadways are closed to traffic. Type III barricades shall extend completely across a roadway (as a fence) or from curb to curb. Where provision must be made for access of equipment and authorized vehicles, the Type III barricades may be provided with movable sections that can be closed when work is not in progress, or with indirect openings that will discourage public entry. Where job site access is provided through the Type III barricades, the applicant/contractor shall assure proper closure at the end of each working day.
- C. In the general case, Type III permanent barricades shall be installed to close arterials or other through streets hazardous to traffic. They shall also be used to close off lanes where tapers are not sufficiently delineated.
- D. Type III barricades shall be used at the end of a local access street terminating abruptly without a cul-de-sac bulb or on temporarily stubbed off streets. Each such barricade shall be used together with an end-of-road marker.

5.08 Bollards

When necessary to deny motor vehicle access to an easement, tract, or trail, except for maintenance or emergency vehicles, the point of access shall be closed by a line of bollards. These shall include one or more fixed bollards on each side of the traveled way and removable, locking bollards across the traveled way. Spacing shall provide one bollard on centerline of trail and other bollards spaced at a minimum of 50 inches on center on trails 10 feet wide or less. Spacing shall be 60 inches on center on trails wider than 10 feet. Bollard design shall be in accordance with figure 5-018 or other design acceptable to the County Road Engineer or Development

Engineer. No fire apparatus access roads shall be blocked in this manner without the concurrence of the Fire Marshal. Bollards shall be located outside the designated clear zone.

5.09 Guardrail/Embankment Heights

New roadways shall be designed with due regard to safety for the traveling public. To ensure a safe roadway configuration, the following features shall be included in the roadway design in order of preference:

1. Provide 4:1 or flatter fill slopes adjacent to the roadway where vertical drops to existing grade are greater than 6'.
2. Provide 3:1 or flatter fill slopes where 4:1 slopes cannot be provided and vertical drops to existing grade exceed 6'.
3. Design location of stormwater runoff ponds where they are not accessible from errant vehicles.
4. Evaluate need for barrier systems and provide design in conformance with WSDOT/APWA Standard Plans, Standard Specifications, and the WSDOT Design Manual

5.10 Roadside Obstacles

Non-yielding or non-breakaway structures exceeding 6 inches in height, including rockeries, retaining walls and any other objects, which may be potential hazards to the traveling public shall be placed with due regard to safety. On shoulder or mountable curb roads, such as rolled curb, extruded curb, or thickened edge, hazardous objects that are essential to the roadway network shall be placed as close to the right-of-way line as practicable and a minimum of 10 feet measured from the edge of the traveled way or edge line and in accordance with figure 5-001.

Non-essential items, (e.g., decorative items) shall not be placed within the right-of-way unless otherwise approved by the County Road Engineer through the road variance process. Additionally, no open water facilities, with the exception of ditches and bio-swailes shall be located within the road right-of-way, unless the County Road Engineer grants a road variance. Landscaping placed within the right-of-way shall meet the minimum requirements specified in Section 5.03 of these Standards.

On urban vertical curb roadways with speed limits less than 40 miles per hour, hazardous objects shall be placed as far from the edge of the traveled way or edge line as practical. Such an object shall not be placed in a sidewalk or with the object edge nearest the roadway less than 8.5-feet from the face of curb in commercial/business areas and 5.5-feet from face of curb in residential areas. On urban roads with speed limits of 40 miles per hour or greater, hazardous objects shall be placed as close to the right-of-way line as practicable and a minimum of 10 feet from the edge of the traveled way or edge line and in accordance with figure 5-001. When sidewalks are constructed or will be constructed in the future, structures shall be placed a minimum

distance of two (2) feet behind the sidewalk. The County Road Engineer or Development Engineer must approve the placement of roadside obstacles within a planter strip, provided the minimum roadside obstacle requirements are met. Placement of utility structures shall be in accordance with requirements of Chapter 8 and figure 5-001 to include constraints on placement of poles on the outside of curves. The applicant or his engineer may apply for the setback variance for the obstacle or utility structure when justified by a traffic safety evaluation. The applicable utility company shall be contacted for the opportunity to submit a written recommendation.

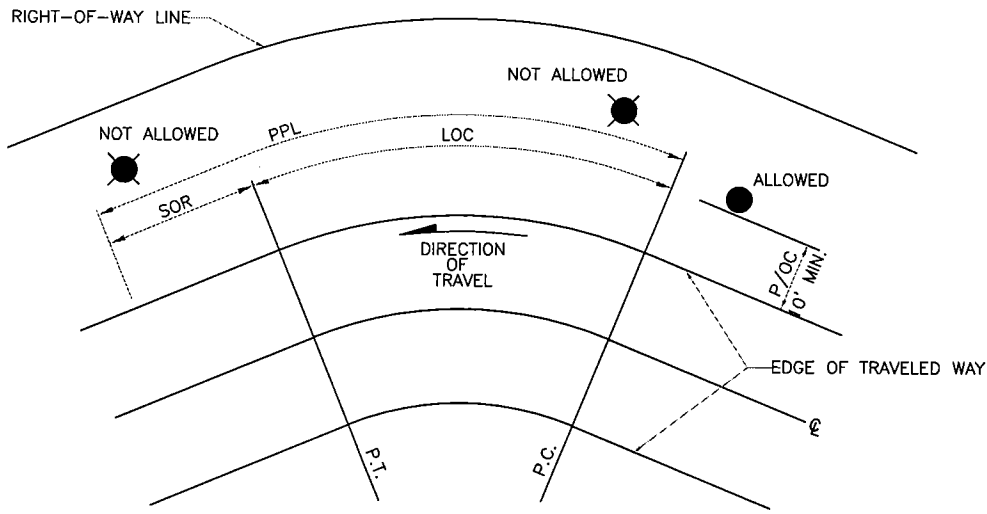

**OUTSIDE OF CURVE
POSTED 40 MPH & OVER**

LOC: LENGTH OF CURVE (FEET) AT EDGE OF TRAVELED WAY FROM P.C. TO P.T.
 SOR: SAFETY OVERRUN (FEET) BEYOND P.T.
 PPL: PROHIBITED POLE LOCATION (PPL)- FEET-FEET (LOC + SOR) WHERE POLES OR OBSTACLES MUST BE REMOVED OR BARRICADED.

PPL (FEET) ON OUTSIDE OF CURVES WITH POSTED SPEED LIMIT OF 40 MPH & OVER		
40 MPH	LOC + 220	(SOR)
45	LOC + 255	
50	LOC + 290	
55	LOC + 325	

APPLIES TO ROADWAY WITH SHOULDER OR MOUNTABLE CURB ON OUTSIDE OF CURVE, WITH:
 -RADIUS LESS THAN 2500 FT., AND
 -POSTED SPEED GREATER THAN OR EQUAL TO 40 M.P.H.

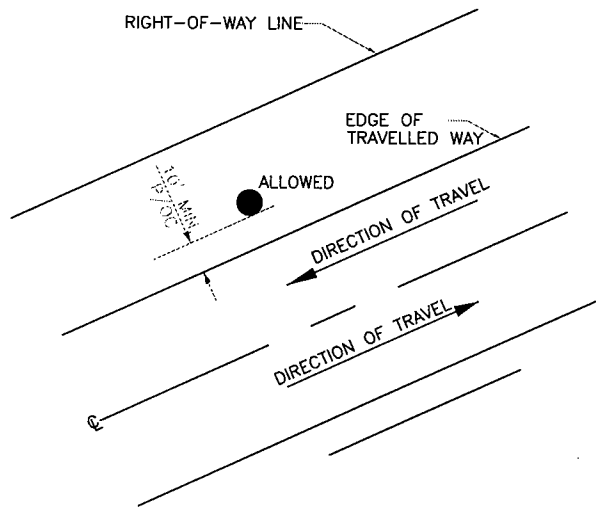

GENERAL CASE

P/O.C: POLE/OBSTACLE CLEARANCE TO NEAREST FACE OF POLE/OBSTACLE.

APPLIES: TO ROADWAY WITH SHOULDER OR MOUNTABLE CURB ON:

1. TANGENT, OR
2. INSIDE OF CURVE, OR
3. OUTSIDE OF CURVE, EITHER WITH
 - POSTED SPEED LESS THAN 40 MPH OR
 - RADIUS GREATER THAN 3500 FT. ON ROADWAY MEETING ALL CURRENT DESIGN STANDARDS.

NOTES:

1. THE STANDARDS SHALL APPLY TO EVERY NEW PLACEMENT AND EVERY PLANNED, NON-EMERGENCY REPLACEMENT OF EXISTING POLES AND OTHER UTILITY STRUCTURES WITHIN KING COUNTY RIGHT-OF-WAY.
2. NO POLES MAY BE REPLACED ON THE OUTSIDE OF A CURVE WITH A POSTED SPEED LIMIT OF 40 MPH OR OVER UNLESS APPROVED THROUGH A VARIANCE REQUEST.
3. SEE SECS. 5.11 & 8.02(G).

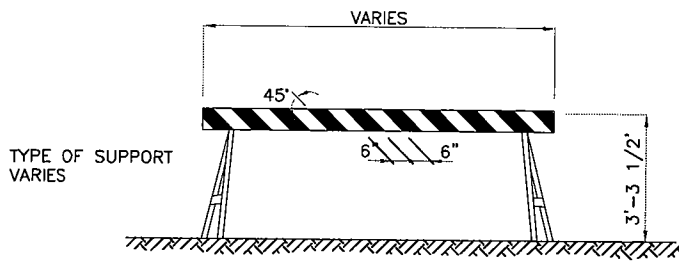

TYPE I BARRICADE

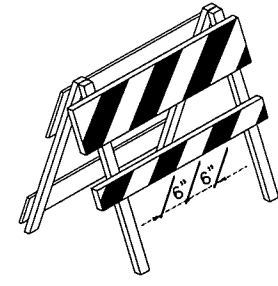

TYPE II BARRICADE



MOVABLE (TEMPORARY)
TYPE III BARRICADE

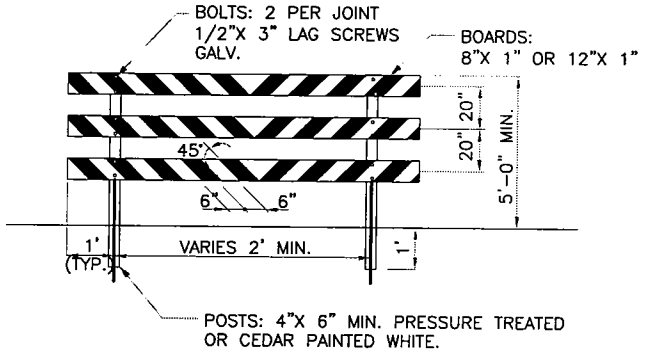

FIXED (PERMANENT)
TYPE III BARRICADE

STRIPE NOTES:

ORANGE & WHITE IF TEMPORARY.
 RED & WHITE IF PERMANENT.
 REFLECTORIZED
 SLANT DOWNWARD, RIGHT OR LEFT,
 IN DIRECTION TRAFFIC WILL PASS.
 SLANT BOTH DIRECTIONS FROM MIDDLE
 IF TRAFFIC PASSES BOTH ENDS.
 WIDTH 6 IN. EXCEPT 4 IN. IF RAILS ARE
 LESS THAN 3 FT. LONG.
 SLANT DOWNWARD TO MIDDLE AT END
 OF DEAD-END OR CLOSED ROAD.
 SEE SEC. 5.07 AND MUTCD SEC.6C-8.

NOTE:

FOR DIMENSIONS NOT SHOWN, SEE TABLE

BARRICADE NOTES:			
TYPE	I	II	III
WIDTH OF RAIL	8" MIN. 12" MAX.	8" MIN. 12" MAX.	8" MIN. 12" MAX.
LENGTH OF RAIL	2' MIN.	2' MIN.	4' MIN.
HEIGHT	3' MIN.	3' MIN.	5' MIN.
TYPE OF FRAME	DEMOUNTABLE, OR HEAVY "A"	LIGHT "A" FRAME	POST OR SKIDS
FLEXIBILITY	ESSENTIALLY MOVABLE	PORTABLE	ESSENTIALLY PERMANENT

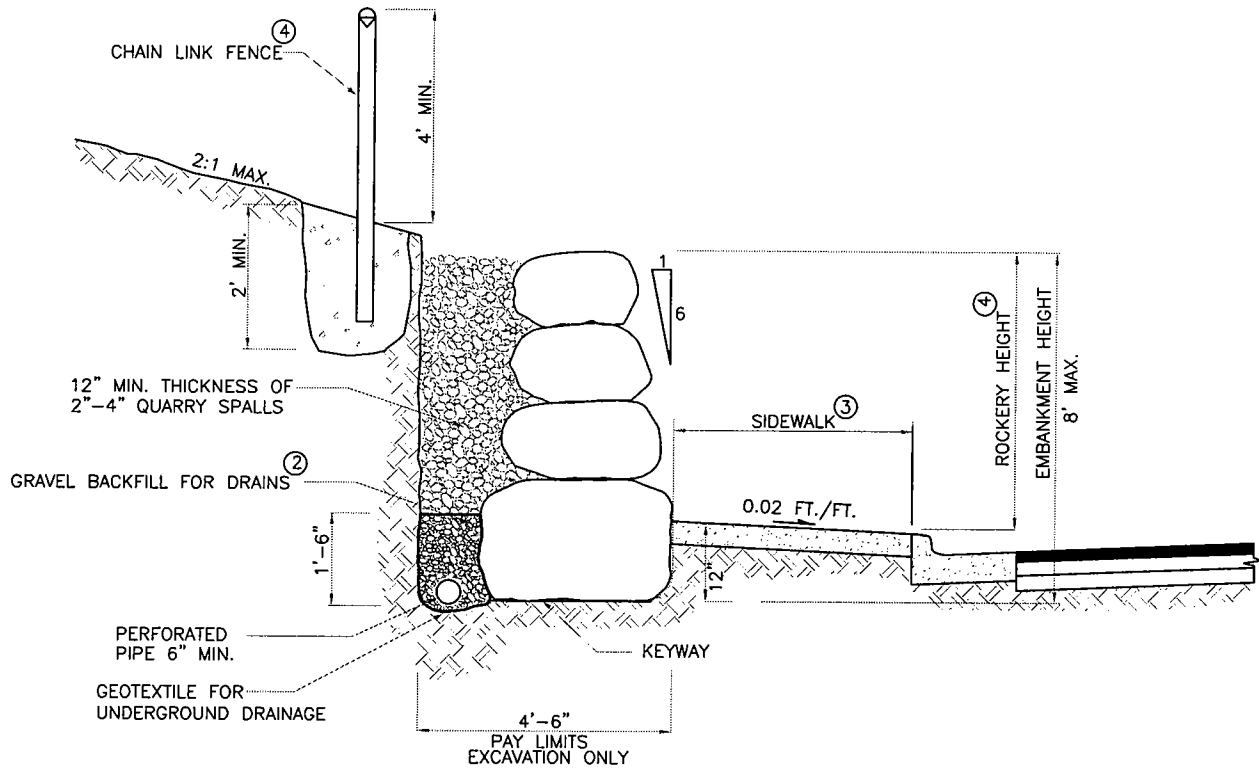

NOTES:

1. SEE SEC. 5.01.
- ② WSDOT/APWA 9-03.12[4]
- ③ FACE OF ROCKERY OR RETAINING WALL MUST BE A MIN. OF 10 FT. FROM TRAVELED WAY IF ROCKERY OR RETAINING WALL IS BEHIND ROLLED CURB OR ON A RURAL SECTION.
- ④ CHAIN LINK FENCE, TYPE NO. 4 OR 6 (WSDOT/APWA STANDARD), REQUIRED WHEN ROCKERY HEIGHT IS 18 IN. OR GREATER.

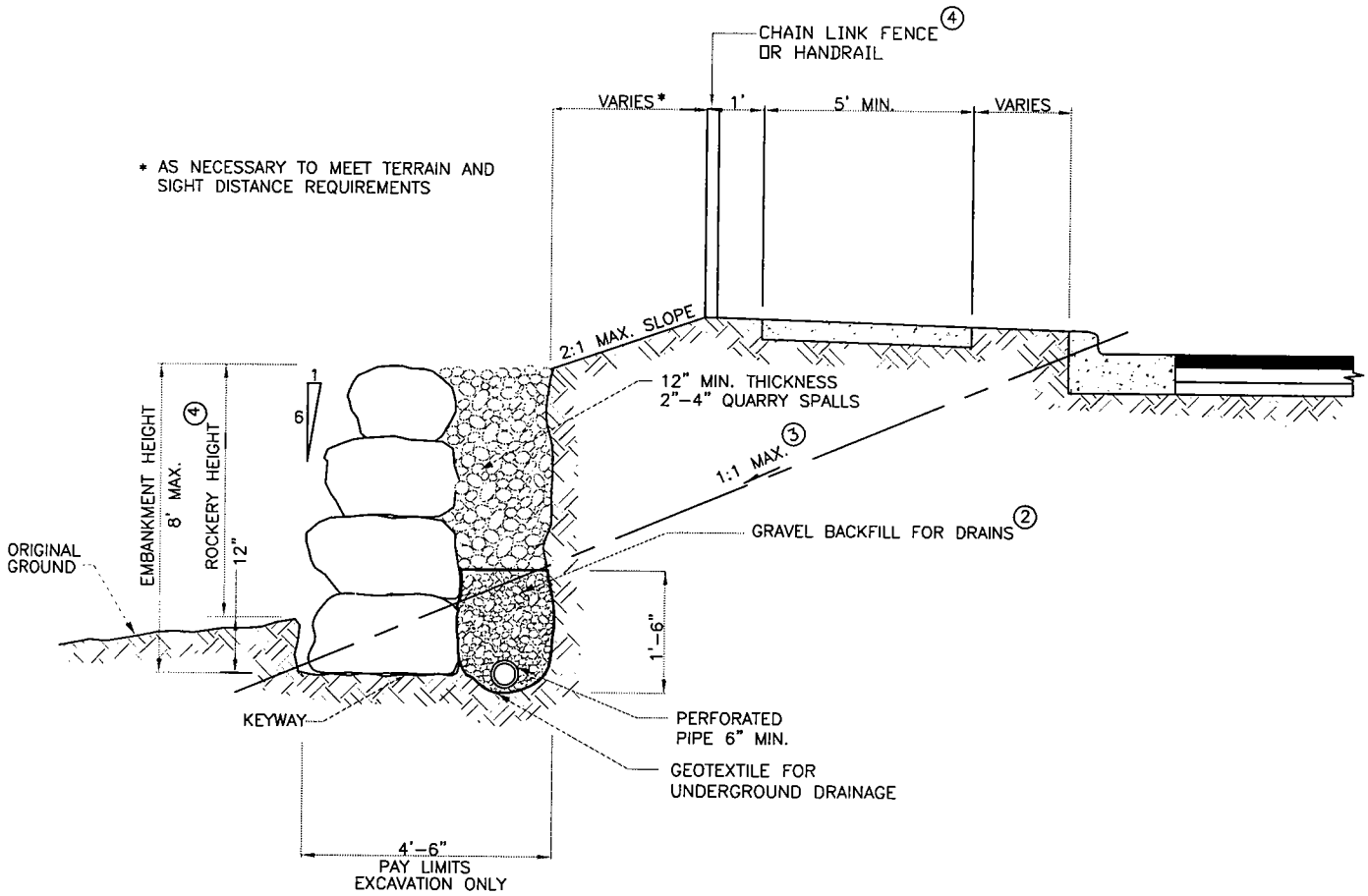

NOTES:

1. SEE SEC. 5.01.
- ② WSDOT/APWA 9-03.12[4].
- ③ FLATTER SLOPE MAY BE REQUIRED IN LESS STABLE SOIL.
- ④ CHAIN LINK FENCE, TYPE NO. 4 (WSDOT/APWA STANDARD) OR HANDRAIL REQUIRED WHEN ROCKERY HEIGHT IS 18 IN. OR GREATER. SEE FIG. 5-008, NOTE 8.
5. FOR ROCKERY HEIGHTS EXCEEDING 4 FT., SEE FIG. 5-006.
6. TRAFFIC BARRIERS MAY BE REQUIRED ON ROADS WITH SPEED LIMITS OF 40 MPH OR GREATER, WHERE ROCKERY HEIGHTS EXCEED 6 FT. SEE CHAPTER 7 OF THE WSDOT DESIGN MANUAL.

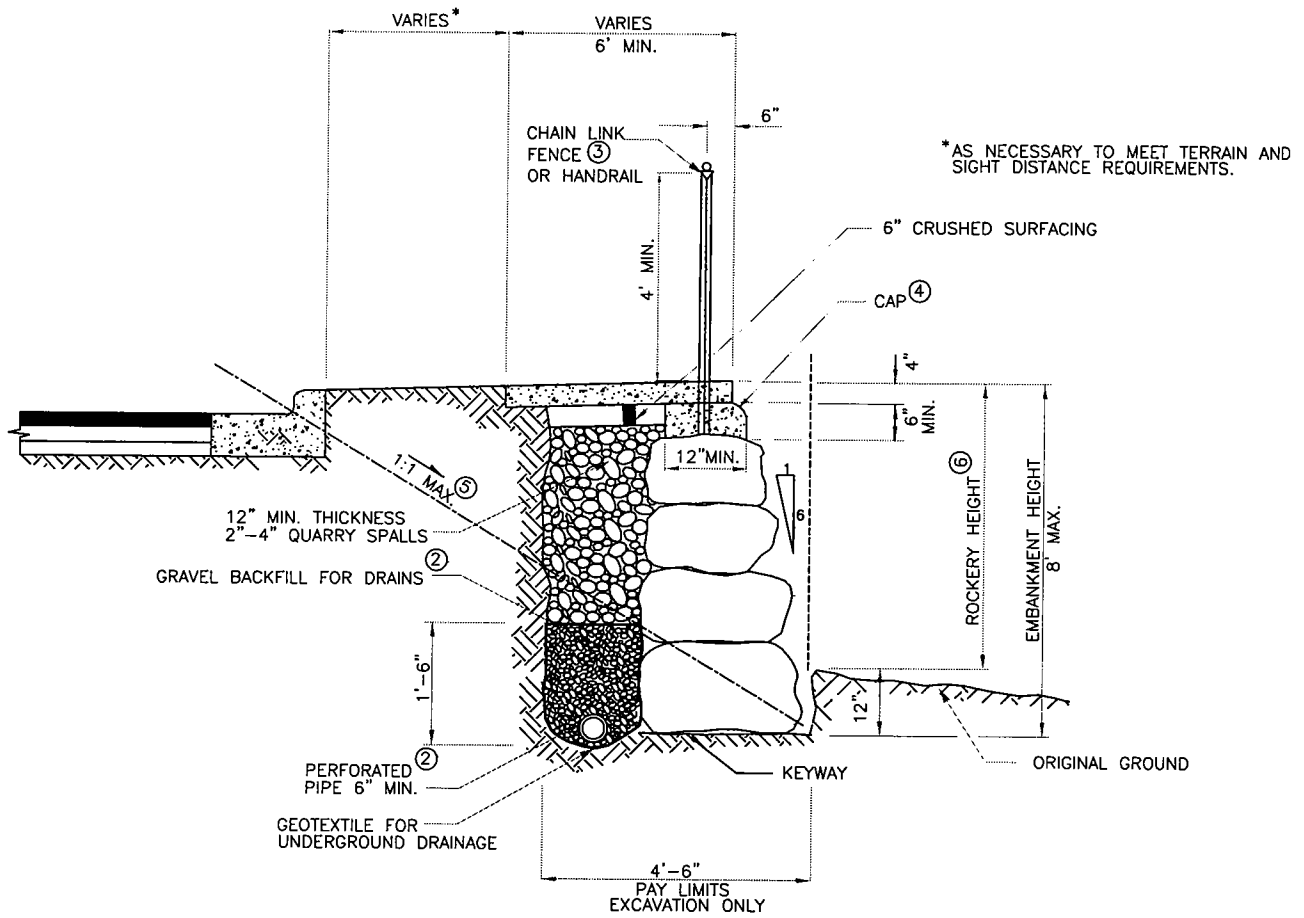

NOTES:

1. SEE SEC 5.01.
- ② WSDOT/APWA 9-03.12[4].
- ③ CHAIN LINK FENCE, TYPE NO. 4 (WSDOT/APWA STANDARD) OR HANDRAIL REQUIRED WHEN ROCKERY HEIGHT IS 18 IN. OR GREATER. SEE FIG. NO. 5-008, NOTE 8.
- ④ CAP SHALL BE CONCRETE CLASS 4000. (SEE SEC. 5.01 (H))
5. FLATTER SLOPE MAY BE REQUIRED IN LESS STABLE SOILS.
- ⑥ FOR ROCKERY HEIGHTS EXCEEDING 4 FT., SEE FIG. 5-006.
7. TRAFFIC BARRIERS MAY BE REQUIRED ON ROADS WITH SPEED LIMITS OF 40 MPH OR GREATER, WHERE HEIGHTS EXCEED 6 FT. SEE CHAPTER 7 OF THE WSDOT DESIGN MANUAL.

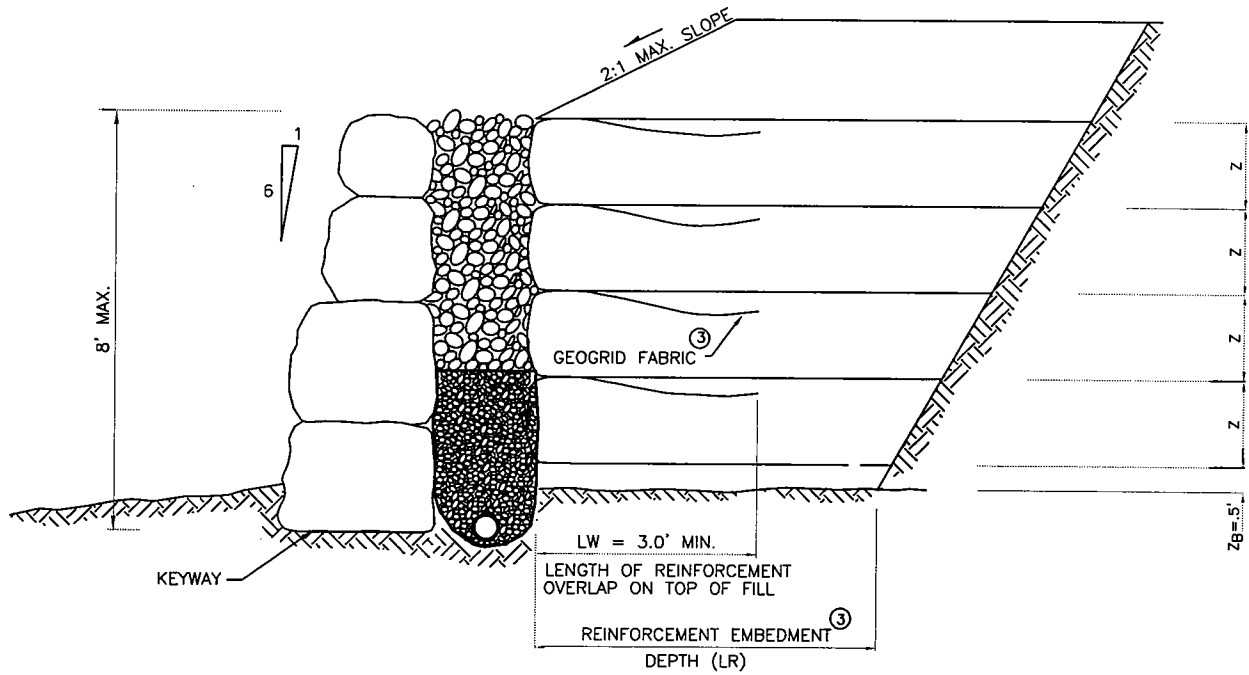

NOTES:

1. ROCKERY FACINGS ARE TO BE CONSTRUCTED TO KING COUNTY ROAD STANDARDS. SEE SEC. 5.01 AND FIG. NO. 5-003 THROUGH 5-005.
2. THE WALL FOUNDATION IS TO BE CLEARED OF ORGANIC MATTER AND DEBRIS AND THE UNDERLYING MINERAL SOIL COMPACTED TO 95 PERCENT OF THE MAX. DRY DENSITY. THE EMBANKMENT MATERIAL IS TO BE GRAVEL BORROW MEETING THE REQUIREMENTS OF 9-03.14 OF THE WSDOT STANDARDS. THE BACKFILL IS TO BE PLACED IN THIN LIFTS, NOT EXCEEDING SIX INCHES IN THICKNESS AND COMPACTED TO 95 PERCENT OF THE MAX. DRY DENSITY.
- ③ GEOSYNTHETIC FABRIC OR GEOGRID REQUIREMENTS INCLUDING TYPE, VERTICAL SPACING (Z), AND EMBEDMENT (LR), WILL BE DETERMINED ON A ROCKERY BY ROCKERY BASIS BY A PROFESSIONAL ENGINEER.
4. Z_B IS HEIGHT OF FIRST LAYER OF REINFORCEMENT ABOVE COMPACTED SUBGRADE ELEVATION.
5. EMBANKMENTS BEHIND ROCKERIES EXCEEDING 4 FT. IN HEIGHT SHALL BE REINFORCED WITH GEOSYNTHETIC FABRIC OR GEOGRID.
6. CHAINLINK FENCE TYPE #4 OR 6 (WSDOT/APWA STANDARD) REQUIRED WHEN ROCKERY HEIGHT IS 18 IN. OR GREATER.

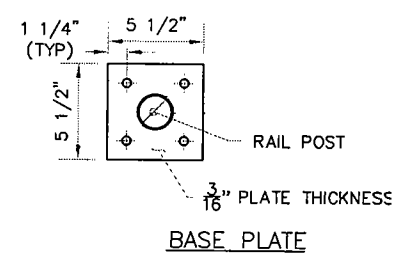
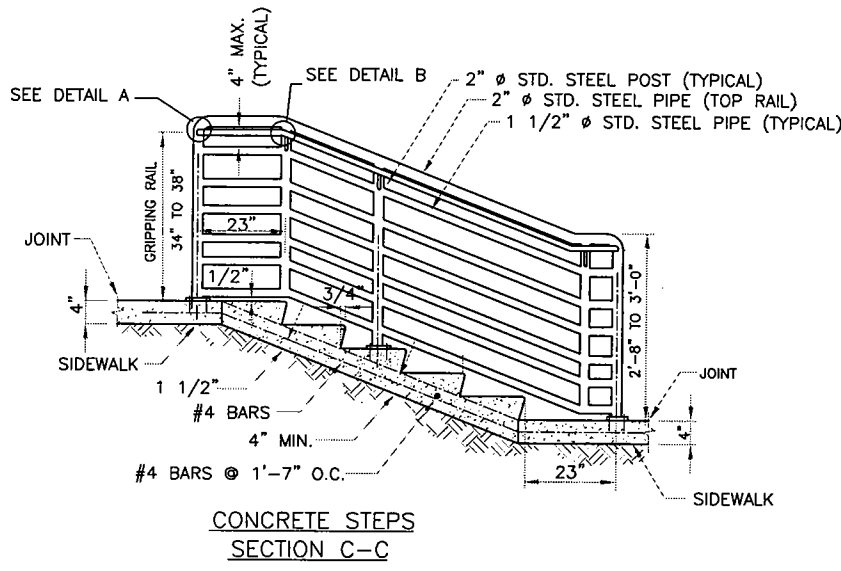
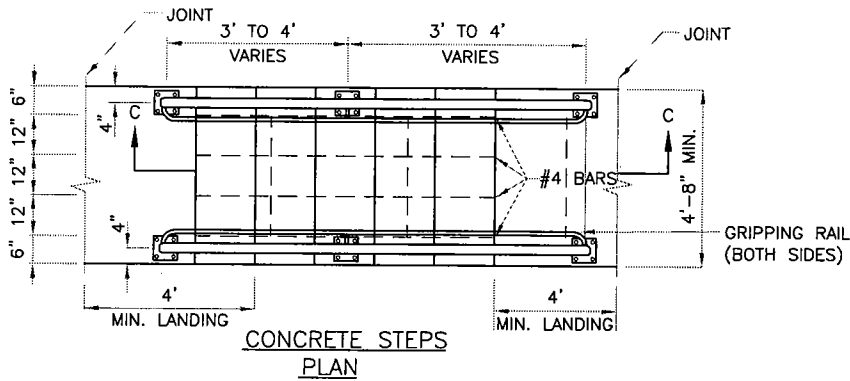

- NOTES**
1. A307, 1/2 BOLTS MIN.
 2. 2 1/2 INCH. CONCRETE EMBEDME
 3. PLATE MATERIAL MIN. A36

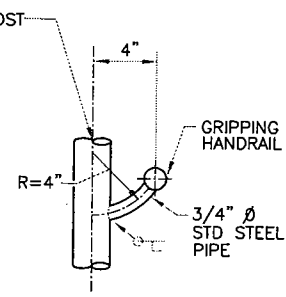
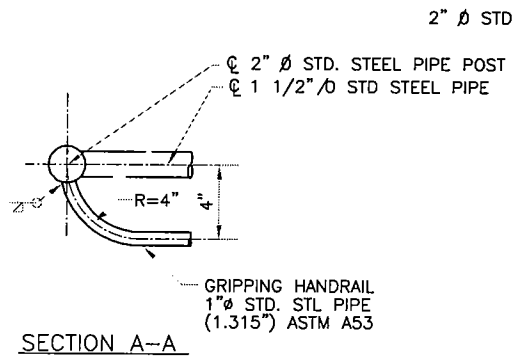
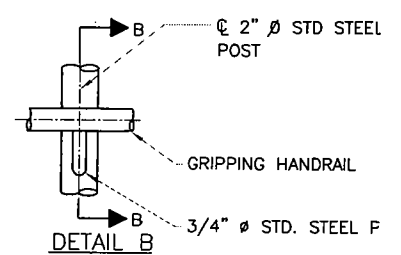
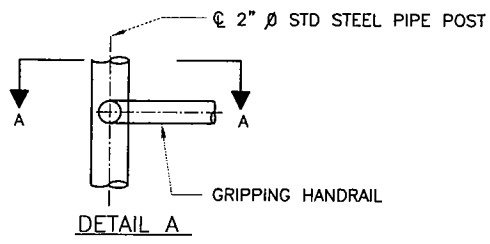

- NOTES :**
1. CONCRETE: CEMENT CONCRETE CLASS 3000.
 2. ALL STEPS: SAME DIMENSIONS, WITHIN 3/8 IN. MAX. DIFFERENCE.
 3. RISERS: 7 1/2 IN. MAX., 5 IN. MIN.
 4. TREADS: 12 IN. MAX., 11 IN. MIN., WITH TRANSVERSE 0.01 FT./FT. SLOPE.
 5. METAL HANDRAIL REQUIRED FOR 4 STEPS OR MORE SEE NOTES BELOW.
 6. REINFORCING BARS SHALL MEET THE REQUIREMENTS OF ASTM A-615, GRADE 60 AND ARE REQUIRED FOR 4 STEPS OR MORE.
 7. SEE SEC. 3.06.
 8. MAX. VERTICAL DISTANCE BETWEEN LANDINGS IS 12 FT.

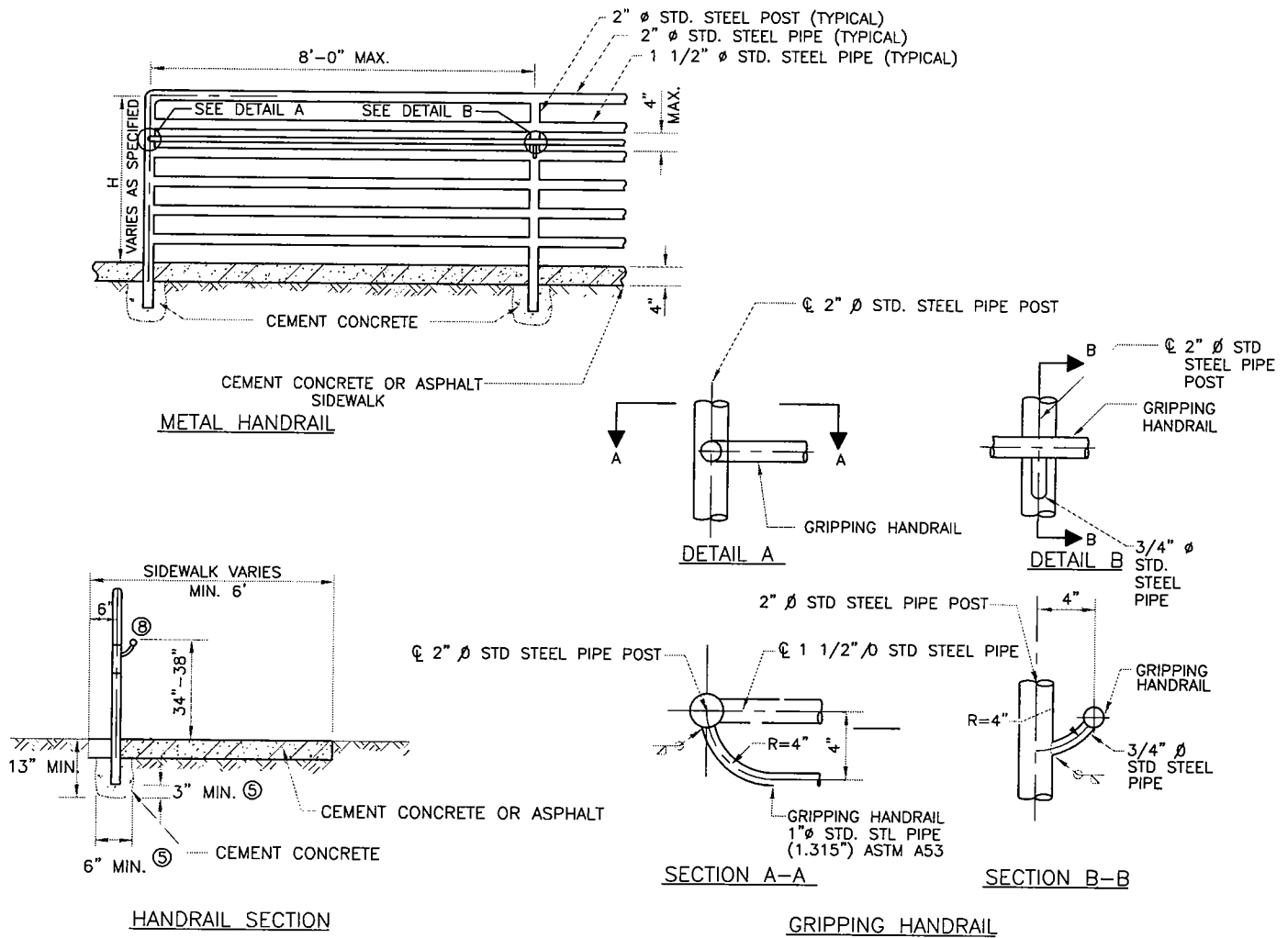

NOTES

1. RAILS TO BE MINIMUM A53 TYPE E, GRADE B, 2 IN. NOMINAL DIAMETER, MINIMUM SECTION MODULUS 0.561 IN 3 (GALV. STEEL OR ALUM?)
2. POSTS, HANDRAILS, CONNECTIONS, JOINTS AND HARDWARE SHALL HAVE A SMOOTH SURFACE.
3. ALL STEEL SHALL BE GALVANIZED. ANY WELDING OR REPAIR IN THE FIELD SHALL BE PAINTED IN ACCORDANCE WITH WSDOT STANDARD SPECIFICATION SECTION 6-07.3.
4. FOOTINGS TO BE MINIMUM CONCRETE CLASS 3000
- ⑤ POSTS SET DEPTH AND CONCRETE FOOTING DIMENSIONS SHALL BE REVIEWED AND DETERMINED BY ENGINEER BASED ON LOCAL SOIL AND SITE CONDITIONS.
6. SEE AASHTO 2.7.2 AND AASHTO 2.7.3. FOR RAIL VERTICAL SPACING REQUIREMENTS.
7. SEE SEC. 3.06.
- ⑧ GRIPPING HANDRAIL IS REQUIRED IF SIDEWALK IS 5% OR GREATER.
9. THE RAILING SHALL MEET THE REQUIREMENTS OF THE AASHTO STANDARDS SPECIFICATIONS FOR HIGHWAY AND BRIDGES.

SEE NOTES 2 AND 5 FOR APPROVAL CONDITIONS

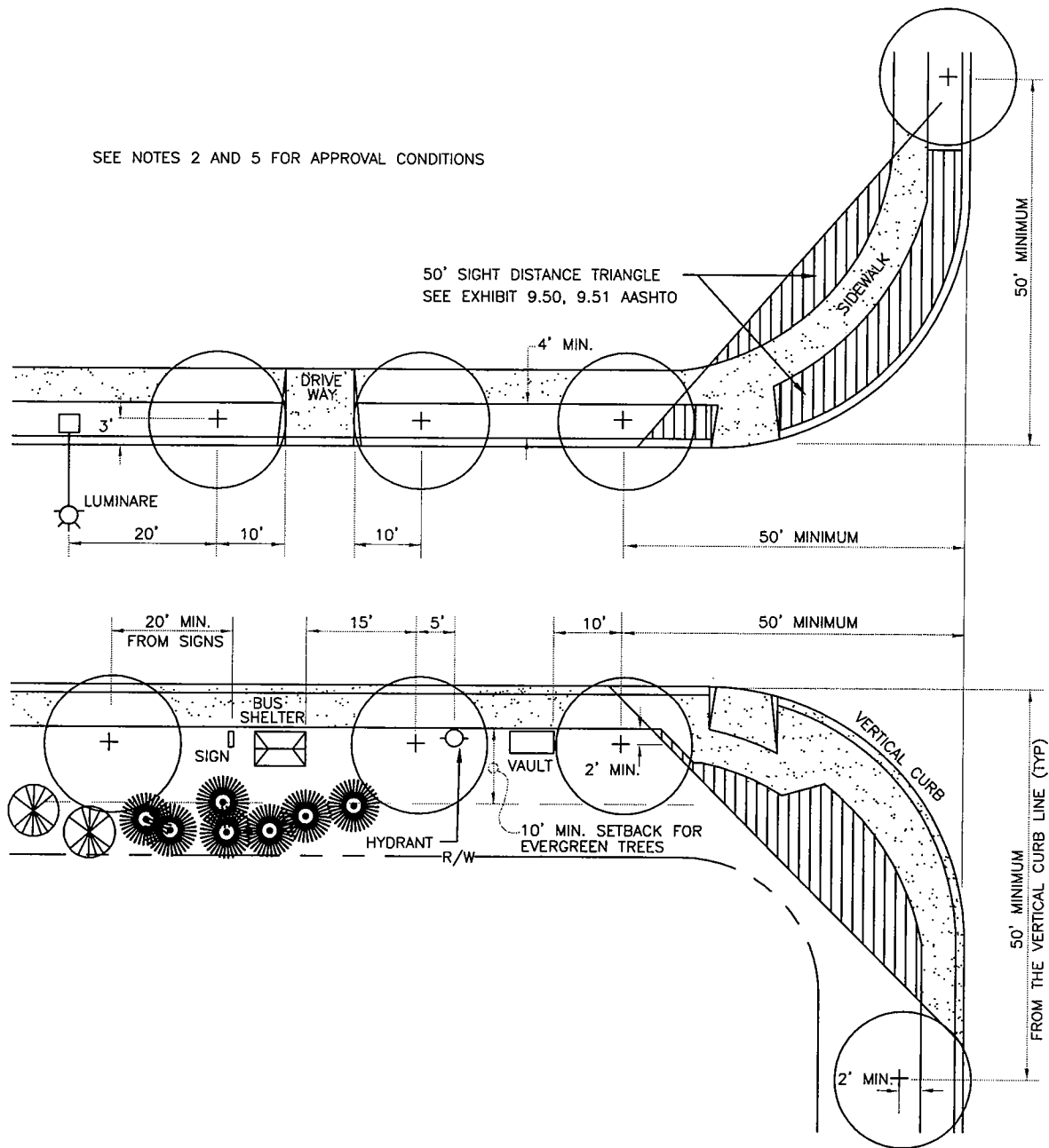

NOTES:

1. TREES SHALL GENERALLY BE PLANTED BACK OF THE SIDEWALK. PLANTING STRIPS WILL BE APPROVED ONLY AS PART OF A LANDSCAPING PLAN IN WHICH PLANT MAINTENANCE, COMPATIBILITY WITH UTILITIES, AND TRAFFIC SAFETY ARE DULY CONSIDERED.
2. IF PLANTING STRIPS ARE APPROVED:
 - A) MIN. DISTANCE FROM CENTER OF ANY TREE TO FACE OF VERTICAL CURB SHALL BE 3 FT.
 - B) TREES SHALL BE STAKED IN A MANNER NOT TO OBSTRUCT SIDEWALK TRAFFIC.
 - C) MINIMUM CLEAR SIDEWALK WIDTH SHALL BE 5 FT. IN RESIDENTIAL OR 8 FT. IN BUSINESS DISTRICTS WHERE BLOCK-OUTS OCCUR.
3. PLANS SHALL BE COORDINATED WITH METRO SERVICE PLANNING ON BUS ROUTES. PHONE 206-684-1622.
4. SEE SEC. 5.03.
5. NO TREES WITH MATURE TRUNKS GREATER THAN 4 IN. DIAMETER (AS MEASURED AT GRADE) SHALL BE PLANTED WITHIN THE KING COUNTY CLEAR ZONE. LARGER TREES MAY BE APPROVED FOR PLANTING OUTSIDE THE CLEAR ZONE AREA. NO TREES SHALL BE PLANTED WITHIN THE 50 FT. SIGHT DISTANCE TRIANGLE AT INTERSECTIONS. ALL PLANTINGS SHALL HAVE A MATURE HEIGHT LESS THAN 24 IN.

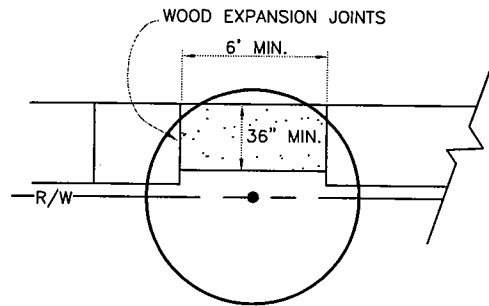
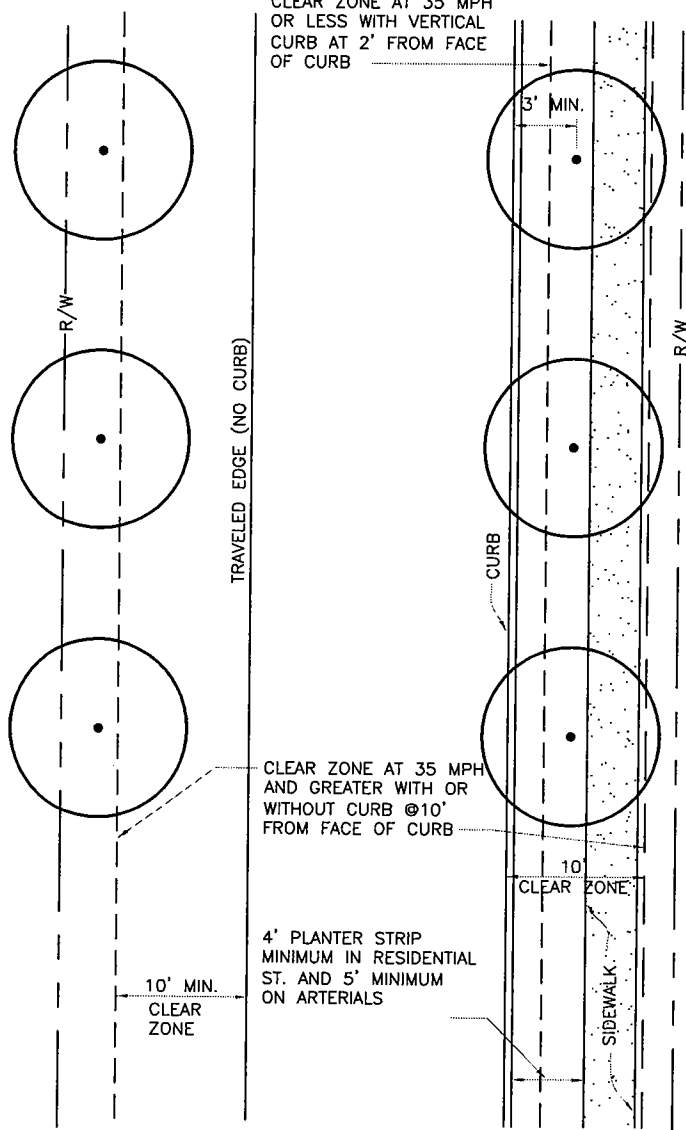

TREE BLOCKOUTS

1. ROOTBARRIERS REQUIRED FOR ALL TREES IN PLANTER STRIP (UNLESS WAIVED BY K.C.D.O.T.)
2. REFER TO FIG. NO. 5-009 FOR SPECIFIC SETBACKS.

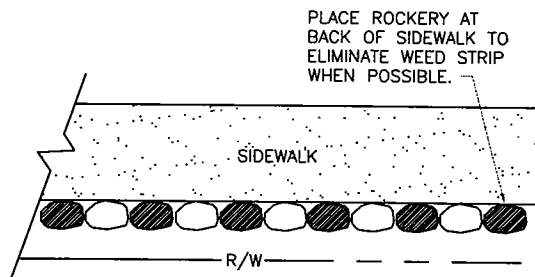

ROCKERIES @ SIDEWALK

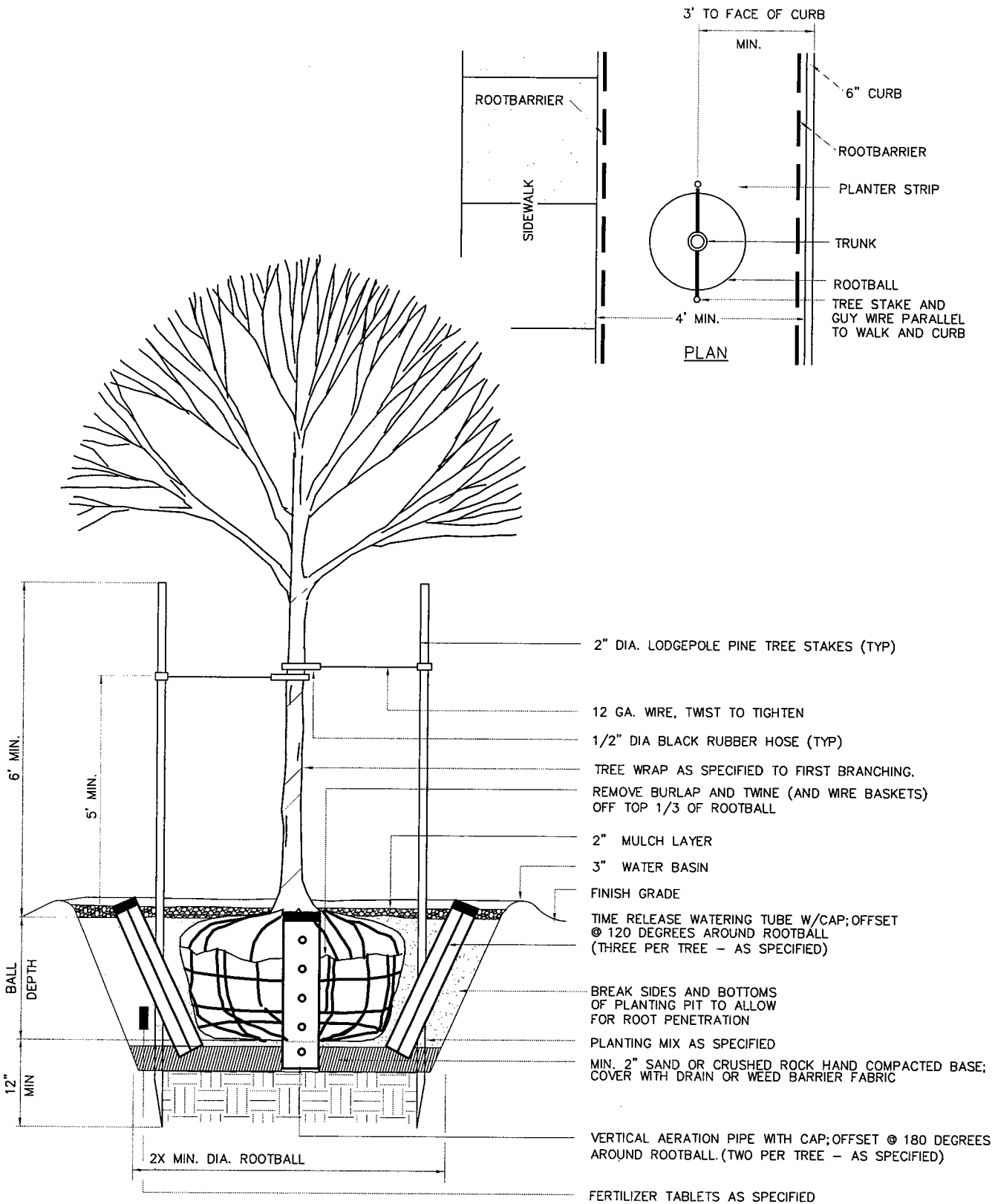

NOTE:

1. PLANT TREES 1 IN. HIGHER THAN DEPTH GROWN IN NURSERY. TREE PIT SHALL NOT BE LESS THAN (2) TIMES DIAMETER OF ROOTBALL.
2. ROOTBARRIER SHALL BE 12 IN. DEEP AND 8 L.F. ON EACH SIDE OF ROOTBALL ADJACENT TO CURBS AND PAVED SURFACES.
3. THERE SHALL BE A MINIMUM ROOTBALL DIAMETER OF 10 IN. PER TRUNK CALIPER INCH AS MEASURED 6 IN. ABOVE ROOTBALL.

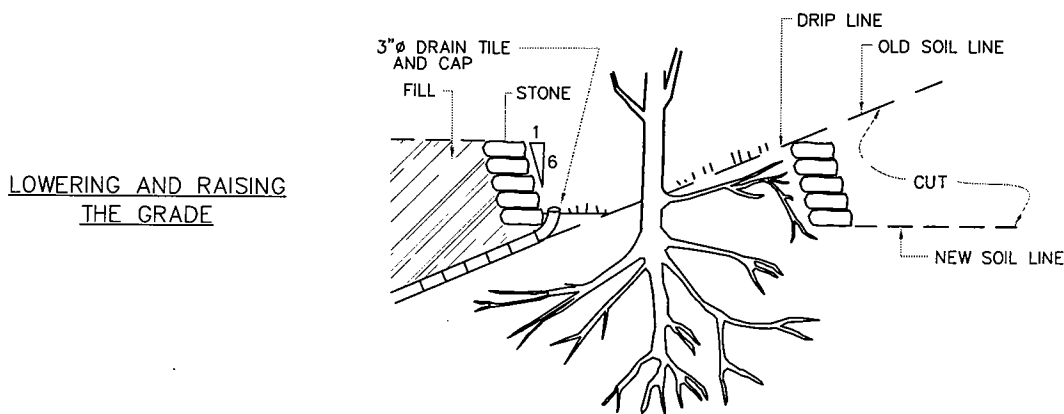
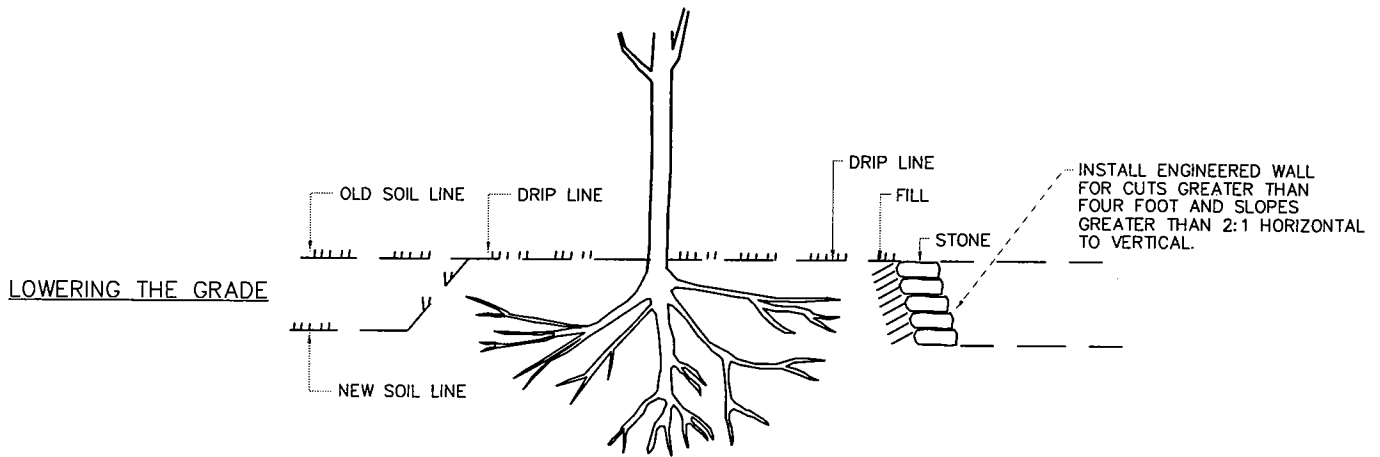
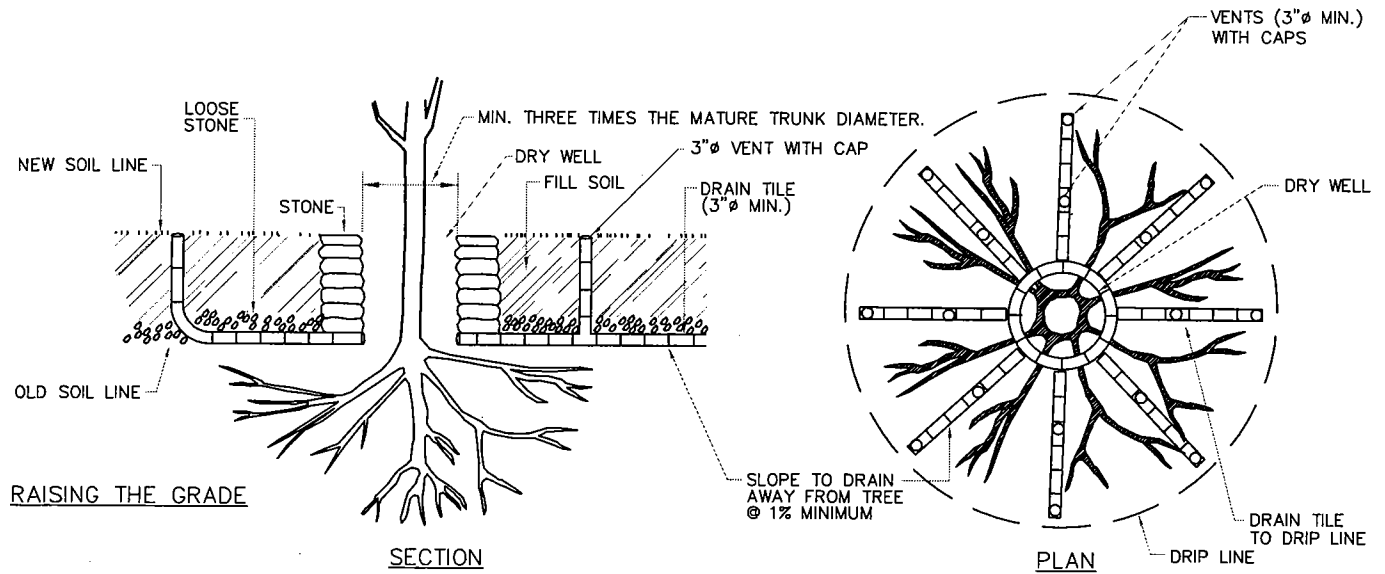

NOTE:

1. ALL DRAIN TILE SHALL BE PERFORATED AND WRAPPED IN PERMEABLE DRAIN FABRIC OR CLOTH SOCKS DESIGNED FOR PERFORATED PIPE.
2. MINIMUM BATTER ON DRY WELLS WALLS SHALL BE 1:6 HORIZONTAL TO VERTICAL.
3. ALL FILL SOIL SHALL BE COMPACTED BY HAND EQUIPMENT ONLY.

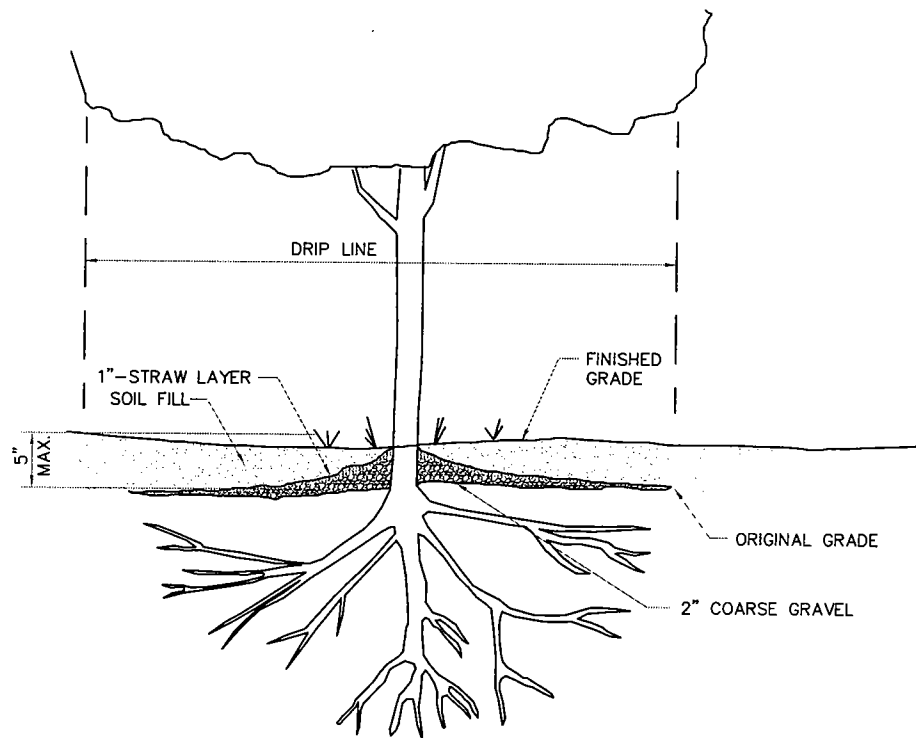

NOTE:

1. EXTEND GRAVEL AND STRAW OUT TO DRIPLINE OF TREE.
2. COMPACT SOIL BY HAND EQUIPMENT ONLY.

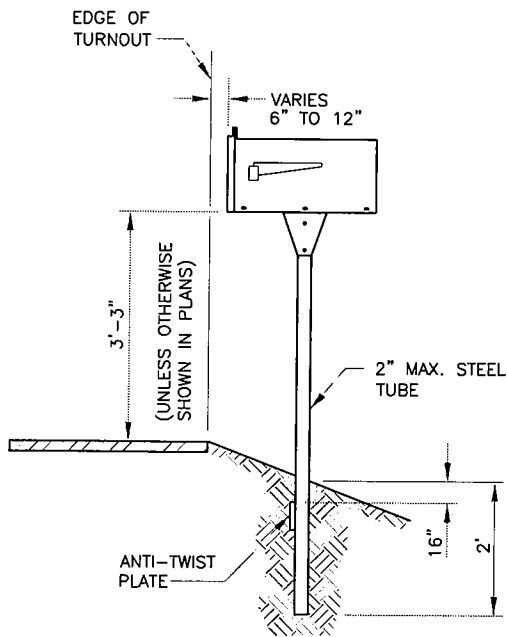

TYPE 1 (STEEL POST OPTION)

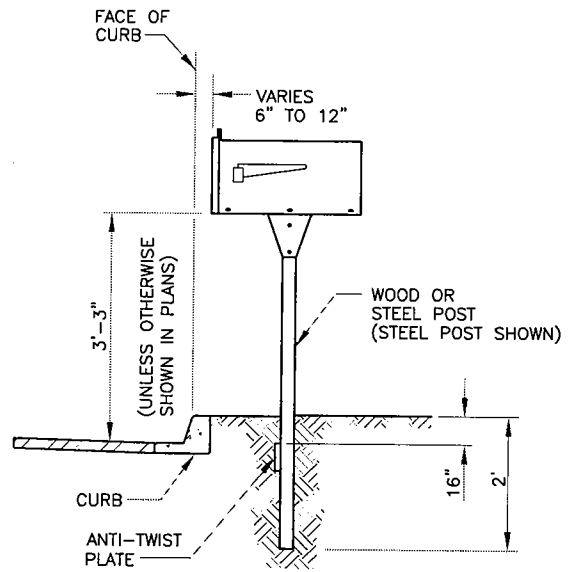

TYPE 1 INSTALLED BEHIND CURB

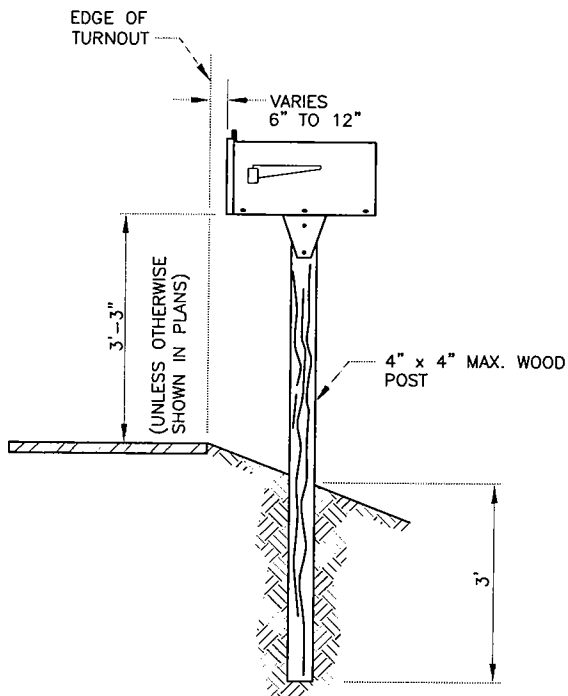

TYPE 1 (WOOD POST OPTION)

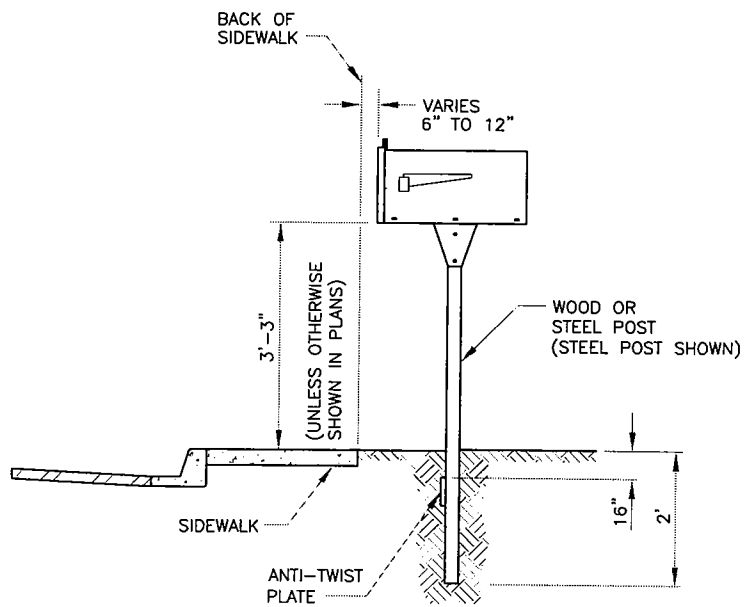

TYPE 1 INSTALLED BEHIND SIDEWALK

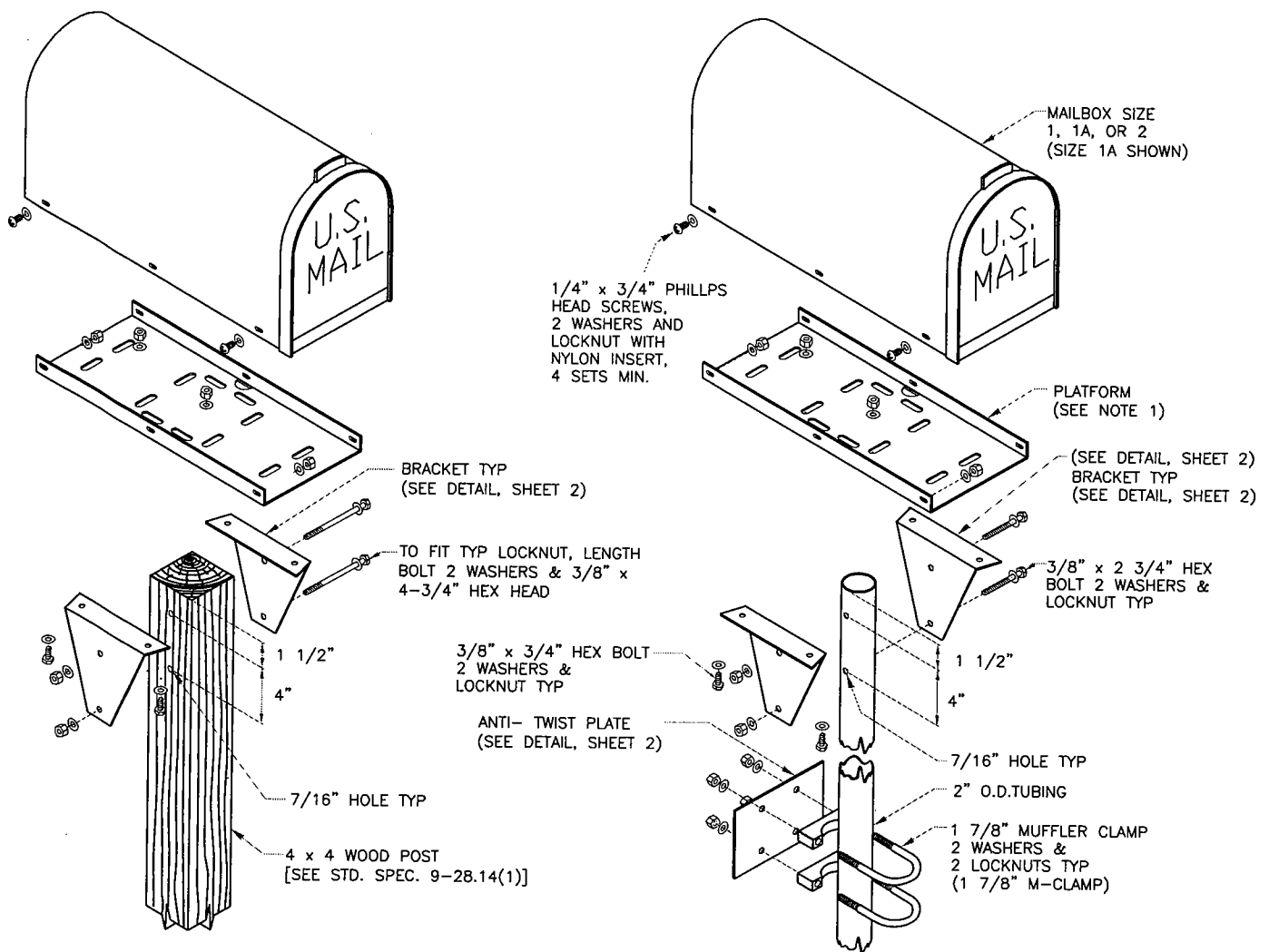

WOOD POST ASSEMBLY DETAIL
 (SEE STEEL POST ASSEMBLY DETAIL
 FOR DETAILS NOT SHOWN)

STEEL POST ASSEMBLY DETAIL

NOTES:

1. AN ALTERNATE PLATFORM MAY BE INSTALLED, PROVIDED THAT IT IS COMPATIBLE WITH THE BRACKET SHOWN.
2. A TYPE 2 SUPPORT IS REQUIRED FOR INSTALLING MULTIPLE MAIL BOXES ON ONE SUPPORT. NO MORE THAN 5 MAILBOXES ARE ALLOWED ON A TYPE 2 SUPPORT.
3. ATTACH A NEWSPAPER BOX TO A STEEL POST WITH TWO 1 7/8" MUFLER CLAMPS SPACED 4" APART. FIELD DRILL 7/16 IN. HOLES IN THE NEWSPAPER BOX TO FIT. USE 2 1/2" x 1/4" LAG BOLTS TO ATTACH NEWSPAPER BOXES TO WOOD POSTS. NEWSPAPER BOXES MUST NOT EXTEND BEYOND THE FRONT OF THE MAILBOX WHEN THE MAILBOX DOOR IS CLOSED.
4. SPACING OF MAILBOX MOUNTING HOLES VARIES AMONG MANUFACTURERS. ATTACHMENT OF THE MAILBOX TO THE PLATFORM MAY REQUIRE DRILLING ADDITIONAL HOLES THROUGH THE MAILBOX TO FIT THE PLATFORM.
5. CENTER THE MAILBOX ON THE PLATFORM TO ENSURE SPACE FOR THE MAILBOX DOOR TO OPEN AND TO ALLOW SPACE FOR INSTALLING THE FASTENERS.

MAILBOX & PLATFORM DIMENSIONS							
SIZE	MAILBOX DIM.			PLATFORM DIM.			
	L	W	H	L	W	H	
1	19"	6 1/2"	8 1/2"	17"	6 3/8"	1"	
1A	21"	8"	10 1/2"	19"	7 7/8"	1"	
2	24"	11 1/2"	13 1/2"	21"	11 3/8"	1"	

STEEL POST FASTENERS			
BOLT SIZE	QUANTITY	WASHERS	LOCKNUTS
3/8" DIA x 2 3/4"	2	4	2
3/8" DIA x 3/4"	4	8	4
1/4" DIA x 3/4"	4	8	4
1 7/8" M-CLAMP	2	4	4

WOOD POST FASTENERS			
BOLT SIZE	QUANTITY	WASHERS	LOCKNUTS
3/8" DIA x 4-3/4"	2	4	2
3/8" DIA x 3/4"	4	8	4
1/4" DIA x 3/4"	4	8	4

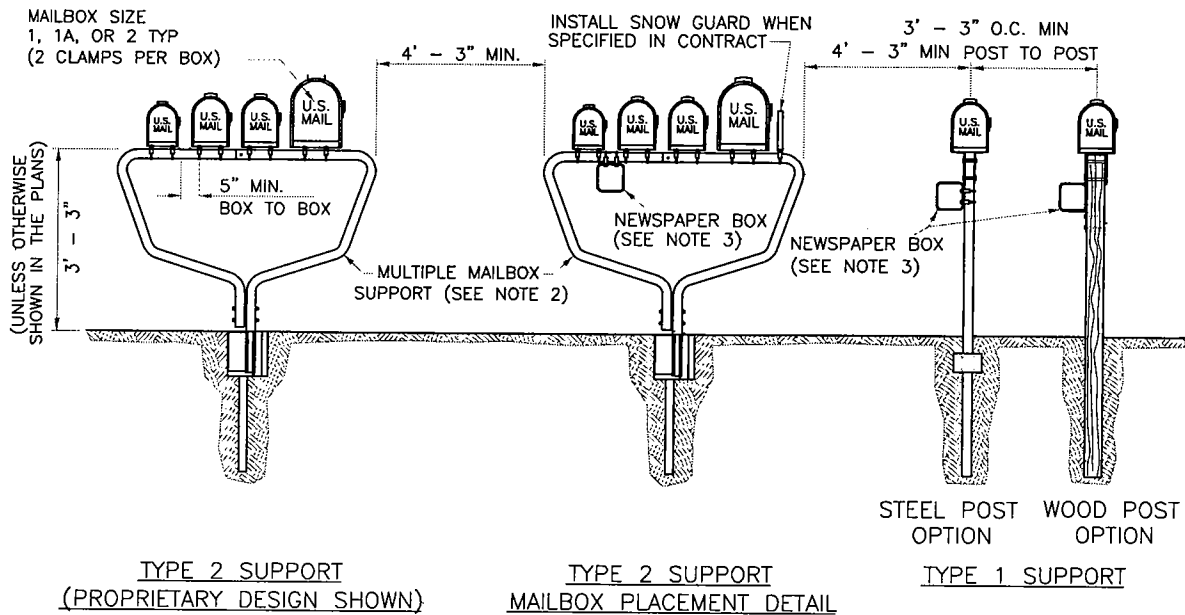
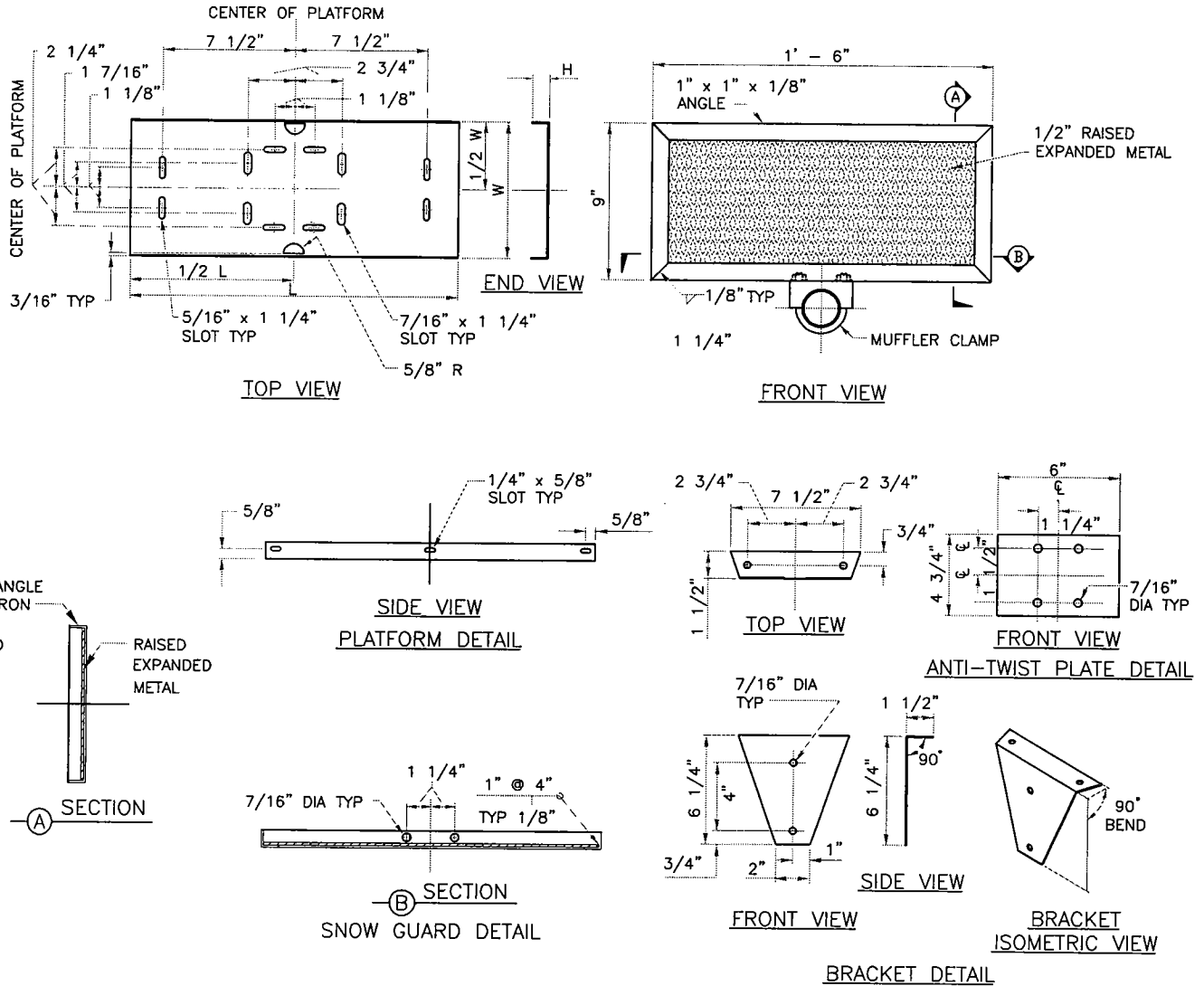

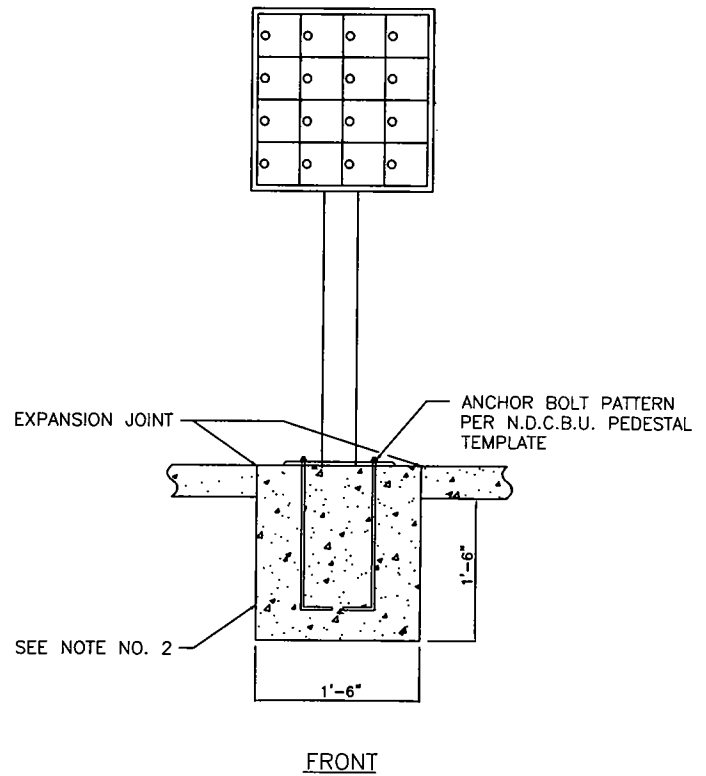
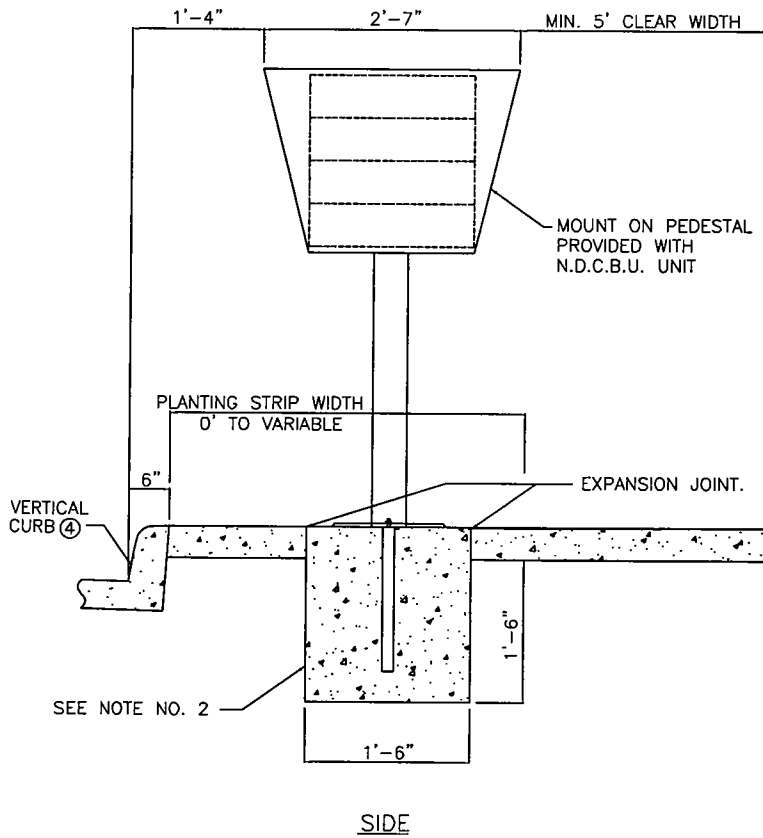

NOTES:

1. SEE SEC. 5.04.
2. INSTALLATION OF N.D.C.B.U. (INCLUDING CONSTRUCTION OF BASE) WILL BE DONE BY U.S. POSTAL SERVICE.
3. SEE SEC. 3.04 FOR JOINT REQUIREMENTS.
4. WHEN A N.D.C.B.U. IS INSTALLED ALONG A ROLLED CURB SECTION, IT SHALL COMPLY WITH SECTION 5.10.

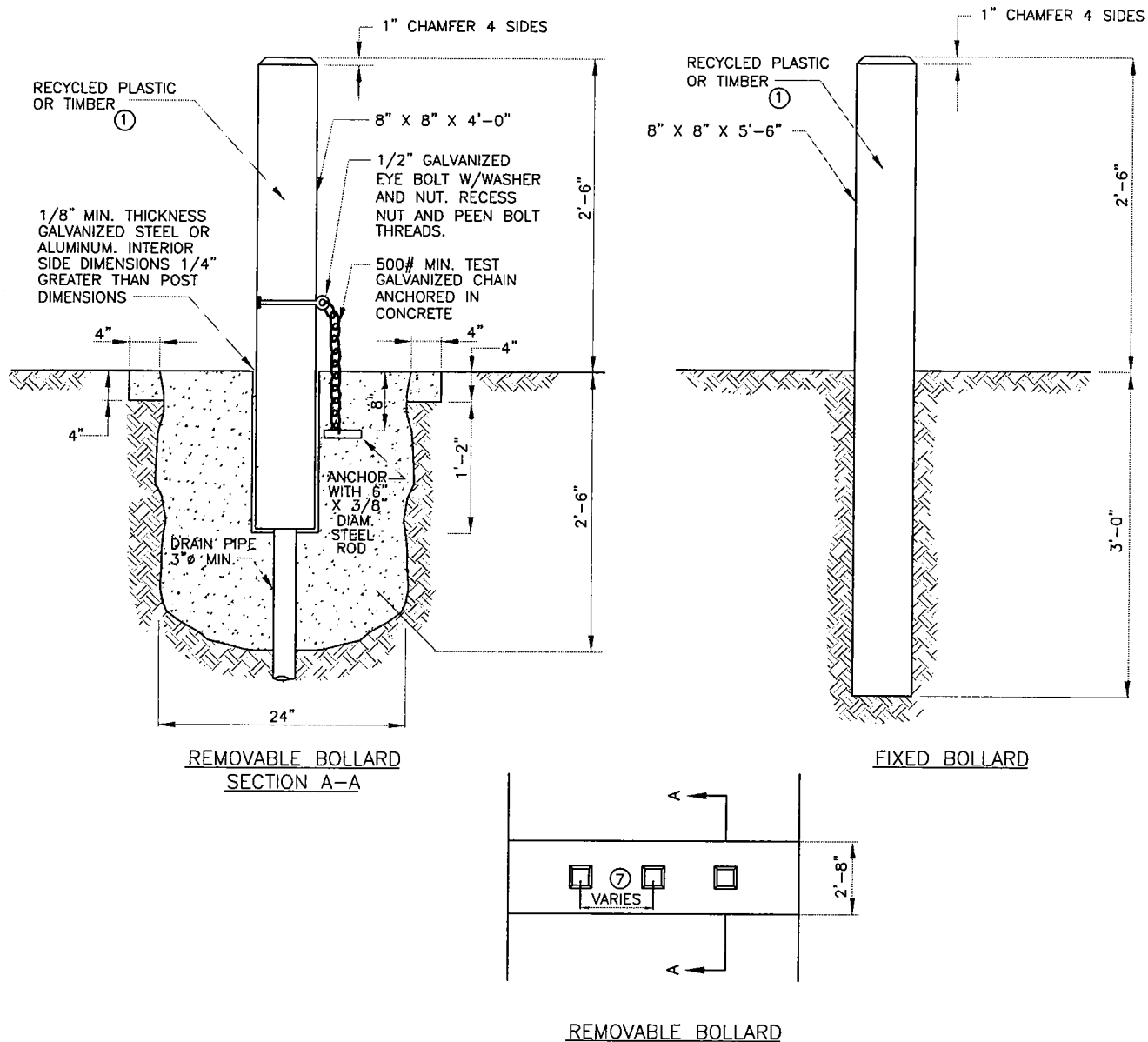

NOTES:

- ① RECYCLED PLASTIC BOLLARD SHALL BE WHITE. TIMBER SHALL BE DOUGLAS FIR, DENSE CONSTRUCTION GRADE, AND SHALL BE PRESSURE TREATED WITH A WATERBORNE PRESERVATIVE (ACA, CCA, ACZA) IN ACCORDANCE WITH THE REQUIREMENTS OF SEC. 9-09.3 (4) OF THE WSDOT/APWA STANDARD SPECIFICATIONS. TOP 5 IN. OF TIMBER SHALL BE PAINTED WHITE.
2. STEEL TUBE SHALL CONFORM TO ASTM A53 GRADE A.
3. NUTS, BOLTS, & WASHERS SHALL CONFORM TO ASTM A307.
4. ALL STEEL PARTS SHALL BE GALVANIZED.
5. CONCRETE SHALL BE CLASS 3000.
6. SEE SEC. 5.08.
- ⑦ MIN. 50 IN. SPACING ON TRAILS LESS THAN 10 FT. WIDE. 60 IN. SPACING ON TRAILS 10 FT. OR WIDER.

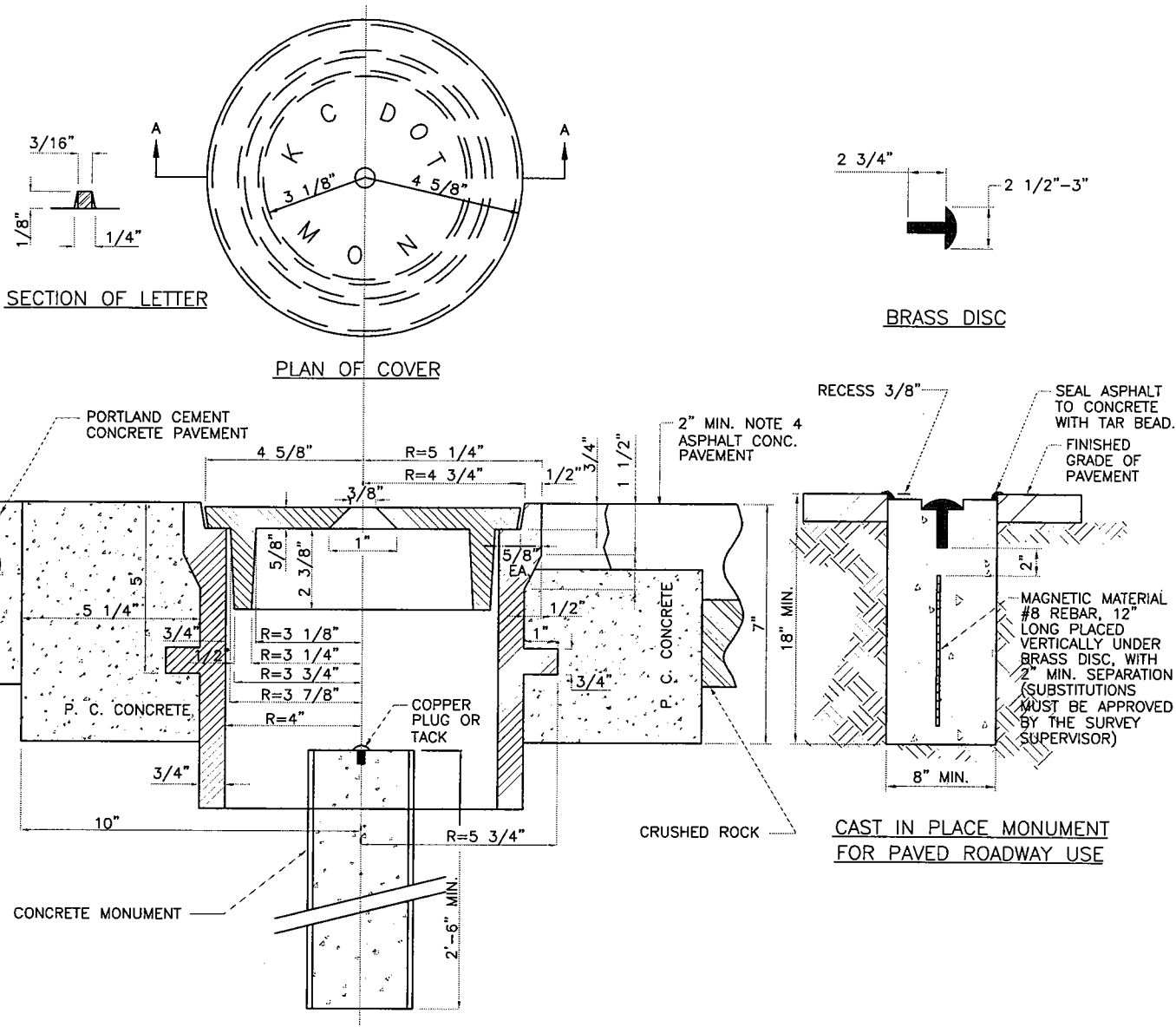

NOTES:

1. CASTINGS SHALL BE GRAY IRON ASTM A48, AASHTO M 105, CLASS 30.
2. COVER AND SEAT SHALL BE MACHINED FOR PERFECT CONTACT AROUND CIRCUMFERENCE AND FULL WIDTH OF BEARING SURFACE.
3. APPROXIMATE WEIGHTS, STANDARD.

CASE	60 LBS
COVER	19 LBS
TOTAL	79 LBS
4. PAVEMENT SHALL BE HOT MIX ASPHALT OR APPROVED SUBSTITUTE.
5. CONCRETE SHALL BE CLASS 4000.

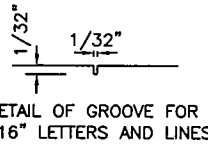
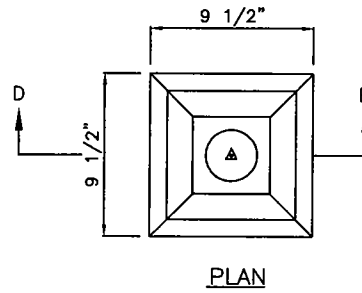
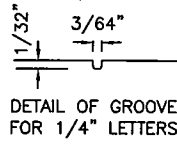
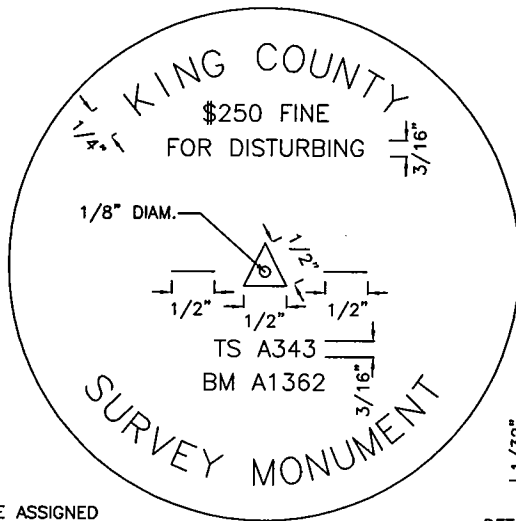

NOTE:
ONLY THE ASSIGNED
IDENTIFICATION
NUMBERS
ARE TO APPEAR ON
THE BRASS DISC.

PLAN

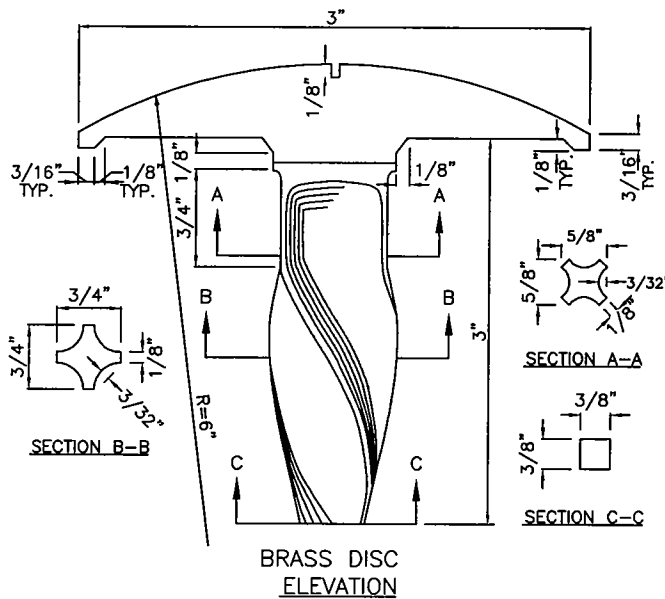

BRASS DISC
ELEVATION

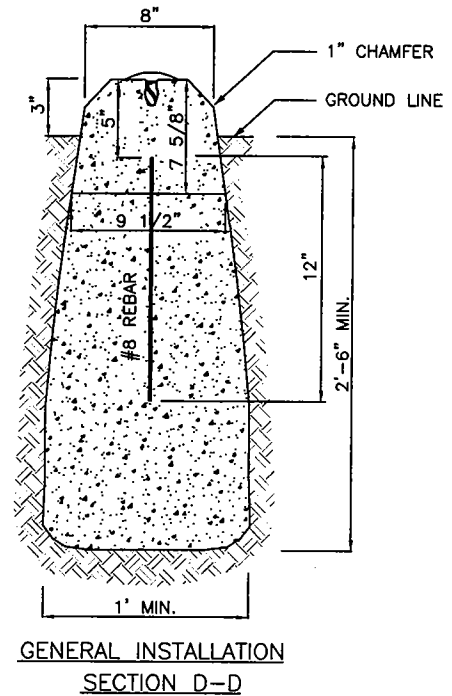

GENERAL INSTALLATION
SECTION D-D

NOTES:

1. THE BRASS DISC SHALL BE CAST OF YELLOW BRASS SAE 41.
2. CONCRETE SHALL BE CLASS 4000.
3. THE HOLE SHALL BE 2.5 FT. MIN. IN DEPTH OR 0.5 FT BELOW THE DEEPEST RECORDED FROST LINE. ALL LOOSE MATERIAL SHALL BE REMOVED FROM THE BOTTOM OF THE HOLE SO THAT THE CONCRETE IS ON FIRM, UNDISTURBED EARTH.
4. THE TOP OF THE CONCRETE SHALL BE TROWLED SMOOTH AND THE BRASS DISC SET IN THE CENTER WITH ITS TOP EDGE FLUSH AND LEVEL.
5. COORDINATES OR ELEVATIONS SHALL NOT BE PLACED ON THE BRASS DISCS.

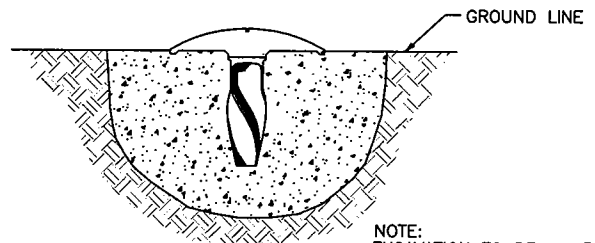

LEDGE ROCK OR
CONCRETE INSTALLATION

NOTE:
EXCAVATION TO BE MADE
LARGE ENOUGH TO
CLEAR MARKER 1 1/2"
AT ALL POINTS.

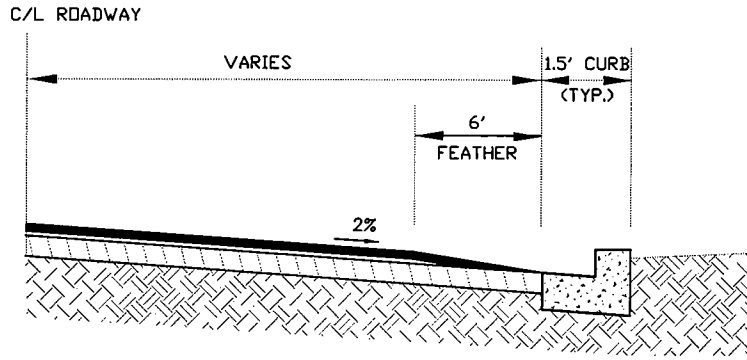

FEATHERING AT VERTICAL CURB

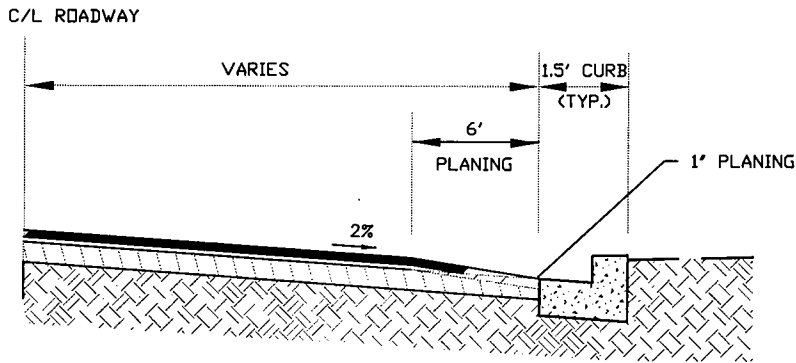

PLANING AT VERTICAL CURB

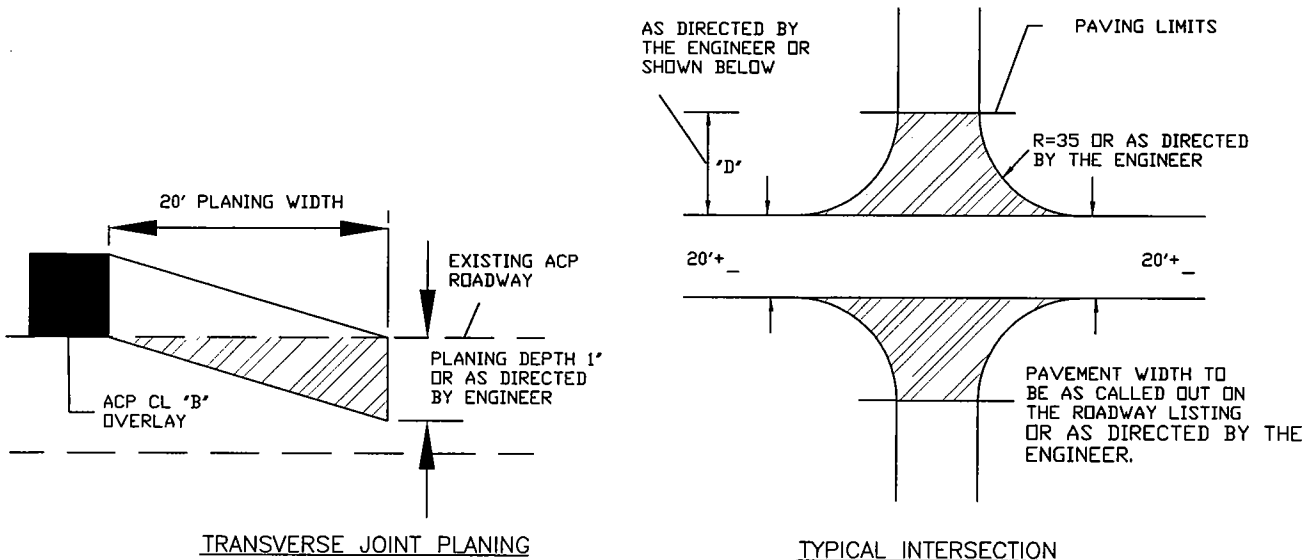

CHAPTER 6. BRIDGES, SPECIAL CULVERTS, AND STRUCTURED WALLS

6.01 Bridge Principal References

Except as specified below, King County bridges, whether on public roads or on private roads, shall be designed and constructed to meet the minimum requirements set forth in the latest edition, including all interim addenda of "AASHTO Standard Specifications for Highway Bridges," or "AASHTO LRFD Bridge Design Specifications" and in accordance with the most current requirements of WSDOT/APWA Standard Specifications. Bridge traffic barrier and approach railings shall be provided in accordance with those references and the WSDOT Bridge Design Manual and WSDOT/APWA Standard Plans. All new bridges shall be designed to carry an AASHTO HS 25 or HL93 (LRFD) unless otherwise approved by the County Road Engineer. The work shall comply with current King County critical area code requirements. Pedestrian bridges shall be designed in accordance with the most current AASHTO "Guide Specifications for Design of Pedestrian Bridges".

6.02 Bridge Geometrics

- A. In general, the bridge shall comprise the full width and configuration of the road being served, (e.g. traveled way plus curb, sidewalks, walkway, bike lane, equestrian lane and/or shoulder on one or both sides). Requirements of utilities shall be duly considered. Bridge roadway width shall be measured between curbs or between faces of bridge traffic barrier; whichever is less.
- B. On designated bike routes, combination bridge traffic barrier and bicycle railings shall be used. Where typical speed is 35 mph or higher and significant pedestrian, bike and/or equestrian traffic can be expected, the County Road Engineer may require that the lanes for these other modes of traffic be separated from motor vehicle traffic by use of a bridge traffic barrier and further protected by a rail at the outer edge.
- C. Approach railings and transitions shall be made structurally continuous with bridge railings and shall meet AASHTO specifications as cited in Section 6.01.
- D. Overhead vertical clearances for motor traffic on the traveled way or under overpasses shall be 16.5 feet minimum. Vertical clearance for bridges over railroad tracks shall comply with the minimum vertical clearance required by the WSDOT Design Manual and also may require negotiations with the railroad company concerning necessary clearances. Vertical clearance of structures above a walkway or sidewalk shall be eight feet minimum and shall be 10 feet minimum on designated equestrian routes unless otherwise specified.
- E. Best available flood data, as defined in the Department of Development and Environmental Services Public Rule, Sensitive Areas: Flood Hazard Areas, shall be used to establish the 100-year water surface elevation in consultation

with the Department of Natural Resources and Parks, Flood Hazard Reduction Services Section

- F. For stream crossing locations where the 100-year peak flow exceeds 100 cfs, the height of bridge clearance above rivers and streams shall be a minimum three feet above the 100-year water surface elevation unless otherwise required by the County Road Engineer based on an evaluation of conveyance factors as specified in subsection G of this section. For stream crossing locations where the 100-year peak flow is 100 cfs or less, there is no specific clearance requirement, but bridges must meet the standards in the King County Surface Water Design Manual.
- G. Evaluation of conveyance factors shall consider hydraulic capacity, bed aggradations, debris passage, safety margins, and bridges and levees, as specified in Section 4.3.3.1 of the Surface Water Design Manual.
- H. For future bridge inspection and maintenance access beneath the actual structure of the bridge, a minimum three feet of clearance between the low chord of the bridge and final grade shall be maintained along the entire bridge.

6.03 Bridge Design Criteria

- A. Unless otherwise approved by the County Road Engineer, concrete approach slabs will be required for all new bridges and shall be constructed in accordance with WSDOT/APWA Standard Plans.
- B. New bridge plans shall be designed in accordance with WSDOT/APWA Standard Specifications to prevent corrosion of reinforcing steel.
- C. Criteria under other recognized road and bridge project classifications, such as those of 3-R projects, set forth in WSDOT Local Agency Guidelines, may be applied under conditions deemed appropriate by the County Road Engineer.
- D. The construction or reconstruction of bridges will necessitate submittal of the following items to the County Road Engineer:
 - 1. Design calculations
 - 2. Load rating analysis
 - 3. Hydraulic report
 - 4. Scour analysis
 - 5. Material certification of the major load bearing members
 - 6. Pile driving records, for all pile supported foundations
 - 7. Plans of Record (As-built plans)
- E. The construction or reconstruction of bridges will necessitate the County Road Engineer's approval of the following:
 - 1. Bridge type

2. Foundation type
3. Size and shape of the hydraulic opening
4. Vertical clearance between the superstructure and the design water surface, including sensitive areas
5. Location of piers and abutments
6. Roadway cross section
7. Bridge traffic barrier and approach guardrail type
8. Aesthetic treatments
9. Expansion joints (the design of bridge expansion joints shall consider the presence of bicycle traffic).

6.04 Special Culverts

All corrugated metal structures and reinforced concrete 3-sided and 4-sided box culverts shall be designed in accordance with the most current AASHTO Standard Specifications for Highway Bridges.

6.05 Structural Walls

Structural retaining walls shall be designed in accordance with the most current AASHTO “Standard Specifications for Highway Bridges” and the most current WSDOT Bridge Design Manual.

CHAPTER 7. DRAINAGE

7.01 General

- A. Designs: Drainage facilities shall be designed consistent with King County Code 9.04 and the King County Surface Water Design Manual, latest edition. No drainage from downspouts, splash blocks, etc. shall discharge across a sidewalk, walkway, or roadway. Structures shall be placed and constructed as shown in the Standard Drawings.
- B. Specifications: Materials, construction, and testing are specified in the WSDOT/APWA Standard Specifications. The County Road Engineer may amend, delete, or add specifications or Standard Drawings.
- C. Conflicts: Where technical conflicts may occur between this document and the Surface Water Design Manual, the County Road Engineer shall decide which document governs.

7.02 Road Ditches

The following standards shall only apply in design of drainage ditches not requiring drainage review under the provisions of the Surface Water Design Manual.

- A. On grades up to 6 percent, grass-lined ditches with grasses as specified in 7.02D shall be used for the drainage requirement. These ditches shall be designed and constructed in accordance with figures 2-001, 2-004 and 2-006. If grass cannot be readily established by usual seeding method, other methods such as sodding or seeding with slope mat protections shall be used as necessary. For grades between 3 percent and 6 percent, grass lining alone may not be sufficient to stop erosion. Preferred methods to further reduce potential erosion problems include the use of check dams, matting, or wider ditch sections. Rock-lined ditches shall be avoided whenever possible. See figure 7-024.
- B. Where the grade is over 6 percent and not over 9 percent, the County Road Engineer may direct use of a standard rock-lined ditch or alternatively a closed (pipe) drainage system under a paved shoulder with asphalt curb or turnpike shoulder. As an exception, cul-de-sacs with over 6 percent grade shall be provided with pipe drainage and not with rock-lined ditches.
 - 1. The standard rock lining shall be in accordance with the Surface Water Design Manual and Section 9-13.6 of the WSDOT/APWA Standard Specifications. Rock gradation shall be as follows:

Passing 8-inch square sieve	100 percent
Passing 3-inch square sieve	40 percent max.
Passing 3/4-inch square sieve	10 percent max.

2. Rocks shall be placed so as to form a firm, dense, protective mat consistent with examples in figure 2-024 and conforming to the design surface of the ditch. Individual rocks shall not protrude more than 3 inches from that surface.
- C. Where the grade exceeds 9 percent, pipe drainage, a special rock-lined ditch or other approved methods shall be provided unless otherwise waived by the County Road Engineer. The special rock-lined ditch shall be designed by a professional engineer, based on soils and hydraulic analyses. Design shall include rock sizing, together with filter rock gradations and/or construction geotextile, and be subject to approval by the County Road Engineer.
- D. Grass seed mixture by weight may be 10 percent Colonial bentgrass, 40 percent Tall or Red fescue, 10 percent White clover, hydroseed at 120 lbs./acre, handseed at 3 lbs./1,000 square feet. Where there is high groundwater, the following species may be substituted or added: Meadow or Pacific foxtail, Timothy, or Redtop.

7.03 Storm Sewers and Culverts

- A. Minimum pipe size shall be 12-inch diameter. Eight-inch diameter may be permitted on cross street laterals less than 66 feet long to avoid utility conflict or meet shallow gradient. Pipe shall be installed in accordance with section 7-08 of the WSDOT/APWA Standard Specifications.
- B. Driveway culverts shall conform to figure 3-003.
- C. Pipes specified in Section 7-02, 7-03, and 7-04 of the WSDOT/APWA Standard Specifications are allowed.
- D. Solid wall polyethylene (SWPE) pipe with maximum SDR of 32.5, minimum cell Class ASTM D3350, 334434C and meeting County Specifications for ductile iron pipe with restrained mechanical joints may be used for outfalls on steep slopes. Above ground installation of SWPE does not require pipe bedding.
- E. Thermoplastic pipe, (e.g., SWPE) shall be tested using the deflection test procedure described in Section 7-17.3 of the WSDOT/APWA Standard Specifications.
- F. Concrete pipe shall be rubber gasketed and metal pipe shall be gasketed and securely banded. Leak testing shall be conducted if required by the County Road Engineer.
- G. Bevel the projecting ends of culverts within the right-of-way per Figure 7-001.

7.04 Catch Basin Locations and Junctions

- A. Catch basins shall be spaced no greater than 150 feet for grades less than one percent, 200 feet for grades between 1 percent and 3 percent and 300 feet for grades 3 percent and greater.

- B. Catch basins, figures 7-003 through 7-006, rather than inlets shall be used to collect storm water from road surfaces, unless approved by the County Road Engineer.
- C. Connections to pipe systems may be made without placing a catch basin or manhole on the mainline by meeting all of the following conditions:
 - 1. The mainline pipe is 48 inches or greater and at least two times the size of the connecting pipe.
 - 2. Make connections in accordance with the manufacturer's recommendations. Standard shop fabricated tees, wyes and saddles shall be used, except for concrete pipe connections constructed in accordance with figure 7-002.
 - 3. There shall be a catch basin or manhole on the connecting pipe within 2 to 10 feet of the external wall of the main line. See figure 7-002.
 - 4. Offset angle of connecting pipe to mainline, horizontally and vertically, shall be less than 45 degrees.
 - 5. 2-point survey control shall be used to set catch basin locations.
- D. Use Type 2 catch basins, figure 7-005, where the depth to the invert of the pipe exceeds 5 feet.
- E. Manholes, figures 7-007 through 7-011, may be used in lieu of catch basins if they do not collect surface water. Manholes must be used if inverts are greater than 18 ft, per figure 7-005.
- F. Roof and yard drains, or other concentrated flow from adjacent property shall not discharge over the surface of roadways, sidewalks, walkways, or shoulders.
- G. Catch basins or manholes are required when joining differing types of pipes.
- H. The location of at least two points of all catch basins shall be surveyed to ensure that the catch basin, frame and grate will properly align with finished curb, horizontally and vertically.

7.05 Frames, Grates, and Covers

- A. Metal castings for drainage structures shall not be dipped, painted, welded, plugged or repaired.
- B. Porosity in metal castings for drainage structures shall be considered a workmanship defect subject to rejection by the inspector.
- C. Castings for manhole rings shall be gray-iron conforming to the requirements of AASHTO M 105, Grade 30B. Covers shall be ductile iron conforming to ASTM A 536, Grade 80-55-06. Manhole rings and covers shall meet the strength requirements of Federal Specification RR-F-621 E. All mating surfaces shall be machine finished to ensure a nonrocking fit.

- D. All manhole rings and covers shall be identified as specified in the WSDOT/APWA Standard Specifications, Section 9-05.15.
- E. Castings for metal frames for catch basins and inlets shall be cast steel, gray iron, or ductile iron as specified in Sections 9-06.8, 9-06.9, or 9-06.14 of the WSDOT/APWA Standard Specifications.
- F. Castings for metal frames for catch basins, inlets, grates and solid metal covers shall meet the strength requirements of Federal Specification RR-F-621 E.
- G. Castings for grates and solid metal covers for catch basins and inlets shall be cast steel or ductile iron as specified in Sections 9-06.8 or 9-06.14 of the WSDOT/APWA Standard Specifications. The foundry name and material designation shall be embossed on the top of the grate. The material shall be identified as “CS” for cast steel and “DUC” or “DI” for ductile iron and shall be located near the manufacturer’s name.
- H. Grates and covers shall be seated properly to prevent rocking, including the replacement of existing covers with solid metal covers.
- I. Subject to prior approval by the County Road Engineer, other types and materials and drainage hardware may be used provided that recognized specifications are available to control quality and acceptable user experience with the product can be shown.
- J. Unless otherwise specified, vaned grates, figure 7-018, shall be used with standard frame in the traveled way, gutter, or shoulder. Vaned grates shall not be located within crosswalks.
- K. At sag vertical curves, on the end of downgrade cul-de-sacs, or before intersections with a grade four percent or greater, an analysis shall be done to assure that typical catch basin grates will collect the surface runoff. To collect excessive volumes of runoff or protect against plugged grates and overflow situations, the County Road Engineer or Development Engineer will require the use of through-curb inlet frames on vertical curbs, figure 7-017. On rolled curbs use through curb frames, figure 7-019, that require a hand formed curb taper extending three feet on either side of the frame. Where the through-curb inlets cannot be used, place a catch basin at the low point and two extra inlets located not greater than 0.1 foot above the low point grate within a spacing of 25 feet.
- L. Use rolled curb frame and (vaned) grates along rolled curbs. See figure 7-021.
- M. New catch basins that do not collect runoff shall use solid locking covers. See figure 7-022. Existing catch basins, which no longer collect runoff, shall have their frame and grates replaced with solid covers, figure 7-015).
- N. All storm drain covers and grates need not be locking. However, when located outside the improved right-of-way area locking lids are required,

unless otherwise approved by the custodial agency; additionally, all control structures storm drain covers shall be locking regardless of their location.

- O. Slit drains may be used when approved by the County Road Engineer. At a minimum slit drains shall have catch basins at either end unless used as a driveway culvert. The maximum distance between catch basins along a slit drain shall be 50 feet.

7.06 Erosion Control

Provide erosion control as required in the King County Surface Water Design Manual or as specified by other guidelines and/or regulatory requirements.

When using geotextile for temporary silt fences, the material shall be designed specifically for erosion control. It shall meet the requirements of WSDOT Standard Specifications or the following minimum requirements:

AOS (ASTM D4751)	30-100 sieve size (0.60-0.15 mm) for silt film 50-100 sieve size (0.30-0.15 mm) for other fabrics
Water Permeability (ASTM D4491)	0.02 sec ⁻¹ min.
Grab Tensile Strength (ASTM D4632)	180 lbs. Min. (called extra strength fabric)
Grab Tensile Elongation (ASTM D4632)	30% max.
Ultraviolet (UV) Resistance (ASTM D4355)	70% min.

Fencing must be inspected regularly for damage. Silt fencing does break down under UV light. Sediment collected behind the fence must be removed so that this material does not push the fence over. Geotextile for permanent erosion control and ditch lining shall meet the requirements of WSDOT Standard Specifications.

7.07 Trenches

All trenches shall comply with Section 8.03 of these Standards.

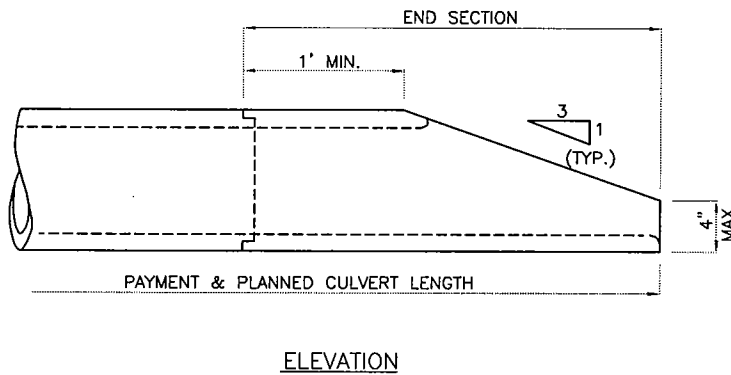
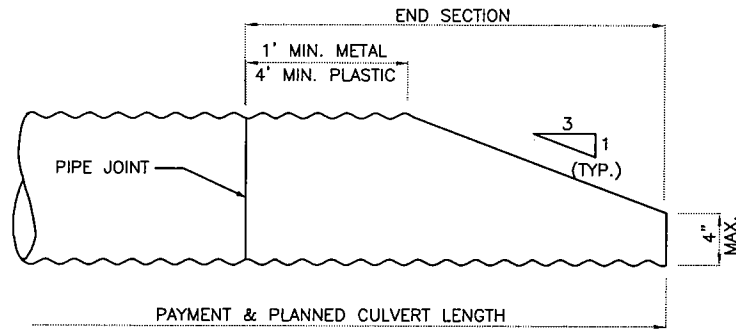
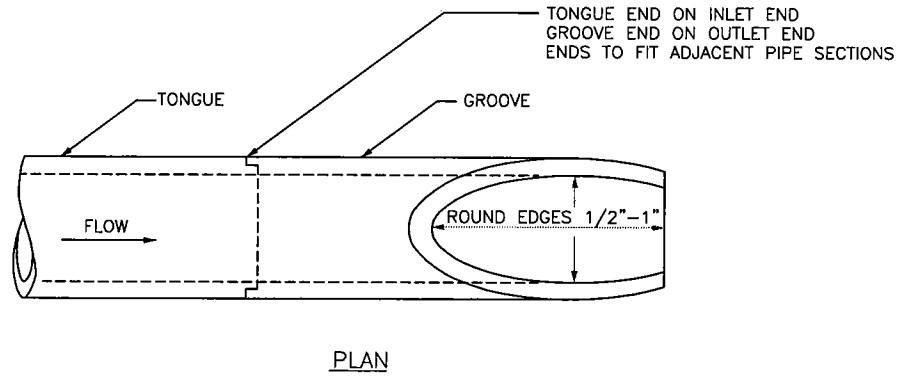

NOTE:

1. SIDE SLOPE SHALL BE WARPED TO MATCH THE BEVELED PIPE END.
2. PIPE SHALL BE BEVELED TO MATCH SLOPE IF SLOPE DIFFERS FROM 3:1.
3. PIPE SHALL BE ROTATED TO CONFORM TO SLOPE WHEN ON SKEW.

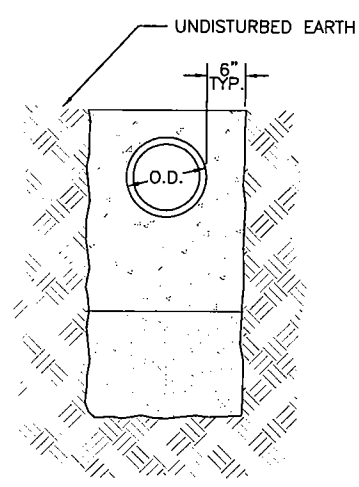
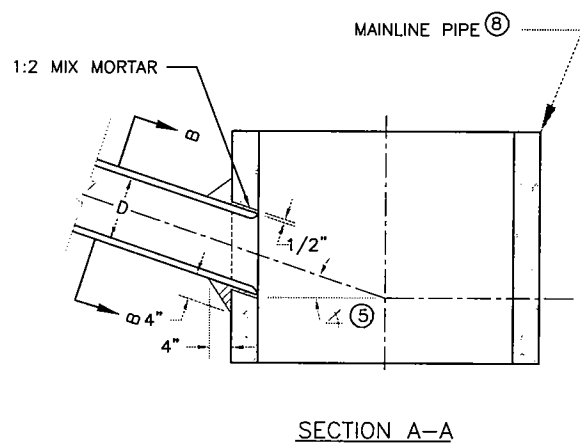
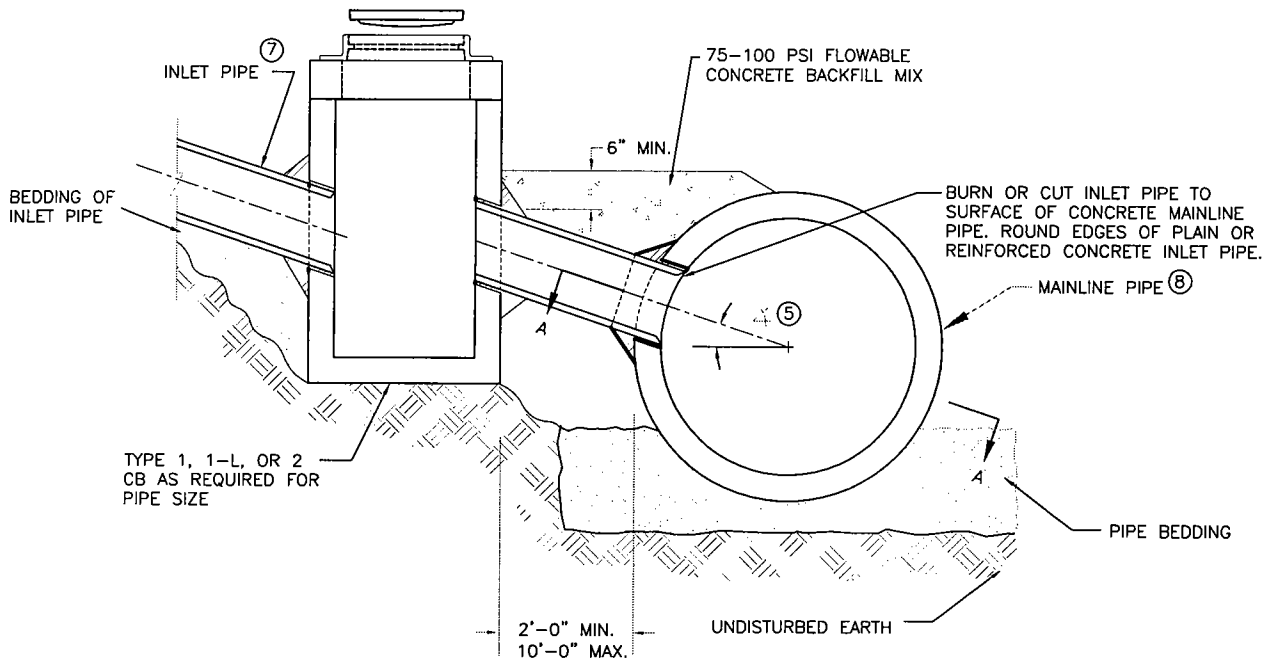

NOTES:

1. "D", THE INSIDE DIAM. OF THE INLET PIPE, SHALL BE 24 IN. OR LESS. FOR LARGER VALUES OF "D", USE AN APPROVED STRUCTURE.
2. IN NO CASE SHALL THE OUTSIDE DIAM. OF THE INLET PIPE EXCEED ONE-HALF THE INSIDE DIAM. OF THE MAIN STORM SEWER.
3. C OF INLET PIPE SHALL BE ON RADIUS OF MAIN STORM DRAIN.
4. THE MIN. OPENING INTO THE EXISTING STORM DRAIN SHALL BE THE OUTSIDE DIAM. OF THE INLET PIPE PLUS 1 IN.
5. FIELD TAPPING ONLY WHERE ANGLE α IS 0° TO 45°.
6. SEE SEC. 7.04.
7. SEE SEC. 7.03 FOR ALLOWED INLET PIPE TYPE.
8. MAINLINE SHALL HAVE 48 IN. MIN. DIAM.

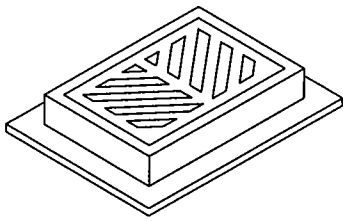

FRAME AND GRATE
SEE SEC. 7.05 AND
APPLICABLE DETAILS.

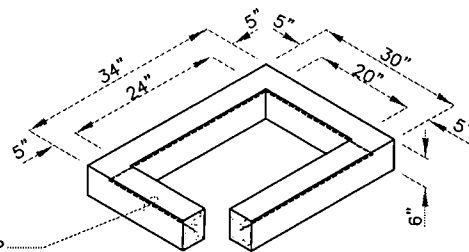

1 #3 BAR HOOP

6" RISER SECTION

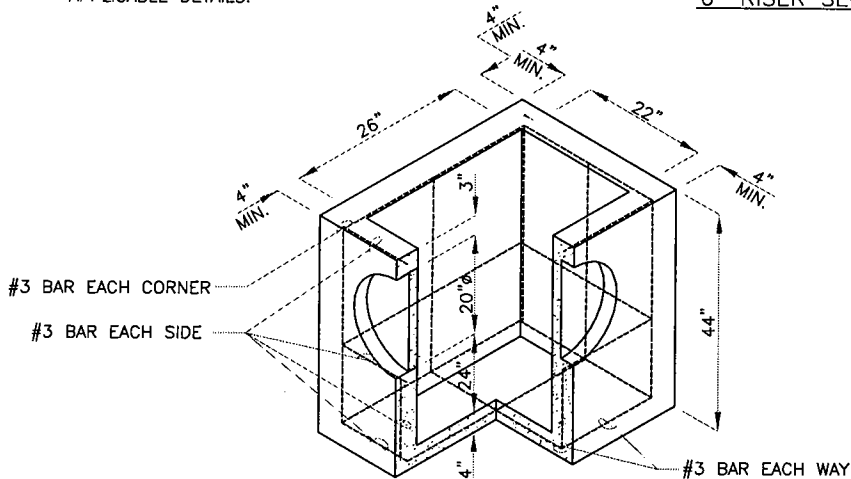

PRECAST BASE SECTION
(MEASUREMENT AT THE TOP
OF THE BASE)

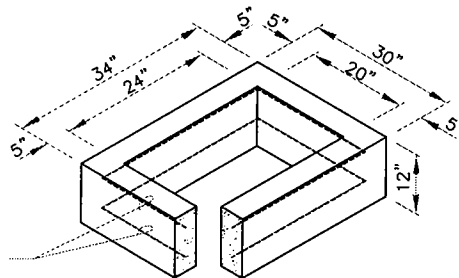

2 #3 BAR HOOPS

12" RISER SECTION

NOTES:

1. CATCH BASINS SHALL BE CONSTRUCTED IN ACCORDANCE WITH ASTM C478 (AASHTO M 199) & C890 UNLESS OTHERWISE SHOWN ON PLANS OR NOTED IN THE WSDOT/APWA STANDARD SPECIFICATIONS.
2. AS AN ACCEPTABLE ALTERNATIVE TO REBAR, WELDED WIRE FABRIC HAVING A MIN. AREA OF 0.12 SQ. IN. PER FT. MAY BE USED. WELDED WIRE FABRIC SHALL COMPLY TO ASTM A497 (AASHTO M 221). WIRE FABRIC SHALL NOT BE PLACED IN KNOCKOUTS.
3. ALL REINFORCED CAST-IN-PLACE CONCRETE SHALL BE CLASS 4000.
4. PRECAST BASES SHALL BE FURNISHED WITH CUTOUTS OR KNOCKOUTS. KNOCKOUTS SHALL HAVE A WALL THICKNESS OF 2 IN. MIN. ALL PIPE SHALL BE INSTALLED IN FACTORY PROVIDED KNOCKOUTS. UNUSED KNOCKOUTS NEED NOT BE GROUTED IF WALL IS LEFT INTACT.
5. KNOCKOUT OR CUTOUT HOLE SIZE IS EQUAL TO PIPE OUTER DIAM. PLUS CATCH BASIN WALL THICKNESS.
6. ROUND KNOCKOUTS MAY BE ON ALL 4 SIDES, WITH MAX. DIAM. OF 20 IN. KNOCKOUTS MAY BE EITHER ROUND OR "D" SHAPE.
7. THE MAX. DEPTH FROM THE FINISHED GRADE TO THE PIPE INVERT IS 5 FT.
8. THE TAPER ON THE SIDES OF THE PRECAST BASE SECTION AND RISER SECTION SHALL NOT EXCEED 1/2" PER FT.
9. CATCH BASIN FRAME AND GRATE SHALL BE IN ACCORDANCE WITH STANDARD SPECIFICATIONS AND MEET THE STRENGTH REQUIREMENTS OF FEDERAL SPECIFICATION RR-F-621D. MATING SURFACES SHALL BE FINISHED TO ASSURE NON-ROCKING FIT WITH ANY COVER POSITION.
10. FRAME AND GRATE MAY BE INSTALLED WITH FLANGE DOWN OR CAST INTO RISER.
11. FOR CATCH BASINS IN PARKING LOTS REFER TO WSDOT/APWA STANDARD DWG. B1-b.
12. EDGE OF RISER OR BRICK SHALL NOT BE MORE THAN 2 IN. FROM VERTICAL EDGE OF CATCH BASIN WALL.

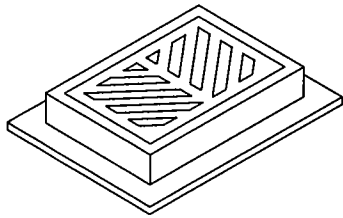

FRAME AND GRATE
SEE SEC. 7.05 AND APPLICABLE DETAILS.

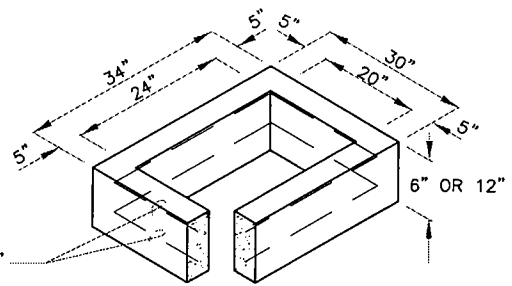

- 1 #3 BAR HOOP FOR 6"
- 2 #3 BAR HOOP FOR 12"

RISER SECTION

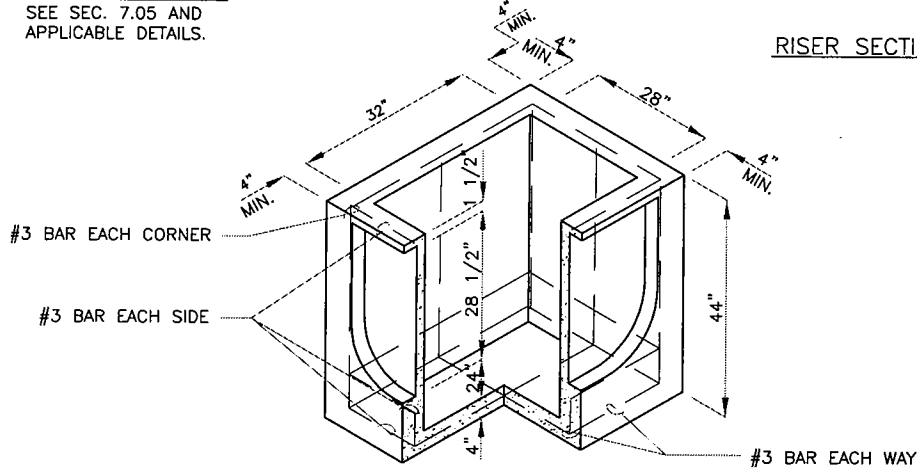

PRECAST BASE SECTION
(MEASUREMENT AT THE TOP OF THE BASE)

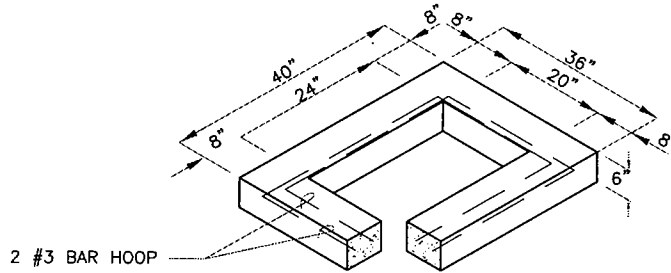

6" REDUCING SECTION

NOTES:

1. CATCH BASINS SHALL BE CONSTRUCTED IN ACCORDANCE WITH ASTM C478 (AASHTO M 199) AND C890 UNLESS OTHERWISE SHOWN ON PLANS OR NOTED IN THE WSDOT/APWA STANDARD SPECIFICATIONS.
2. AS AN ACCEPTABLE ALTERNATIVE TO REBAR, WELDED WIRE FABRIC HAVING A MIN. AREA OF 0.12 SQ. IN. PER FT. MAY BE USED. WELDED WIRE FABRIC SHALL COMPLY TO ASTM A497 (AASHTO M 221). WIRE FABRIC SHALL NOT BE PLACED IN KNOCKOUTS.
3. ALL REINFORCED CAST-IN-PLACE CONCRETE SHALL BE CLASS 4000.
4. PRECAST BASES SHALL BE FURNISHED WITH CUTOUTS OR KNOCKOUTS. KNOCKOUTS SHALL HAVE A WALL THICKNESS OF 2 IN. MIN. ALL PIPE SHALL BE INSTALLED IN FACTORY PROVIDED KNOCKOUTS. UNUSED KNOCKOUTS NEED NOT BE GROUTED IF WALL IS LEFT INTACT.
5. KNOCKOUT OR CUTOUT HOLE SIZE IS EQUAL TO PIPE OUTER DIAM. PLUS CATCH BASIN WALL THICKNESS.
6. KNOCKOUTS MAY BE ON ALL 4 SIDES WITH MAX. DIAM. OF 28 IN. KNOCKOUTS MAY BE EITHER ROUND OR "D" SHAPE.
7. THE TAPER ON THE SIDES OF THE PRECAST BASE SECTION AND RISER SECTION SHALL NOT EXCEED 1/2" PER FT.
8. CATCH BASIN FRAME AND GRATE SHALL BE IN ACCORDANCE WITH STANDARD SPECIFICATIONS AND MEET THE STRENGTH REQUIREMENTS OF FEDERAL SPECIFICATION RR-F-621D. MATING SURFACES SHALL BE FINISHED TO ASSURE NON-ROCKING FIT WITH ANY COVER POSITION.
9. FRAME AND GRATE MAY BE INSTALLED WITH FLANGE DOWN OR CAST INTO RISER.
10. MAX. DEPTH FROM FINISHED GRADE TO PIPE INVERT SHALL BE 5 FT.
11. EDGE OF REDUCING SECTION OR BRICK SHALL NOT BE MORE THAN 2 IN. FROM VERTICAL EDGE OF CATCH BASIN WALL.

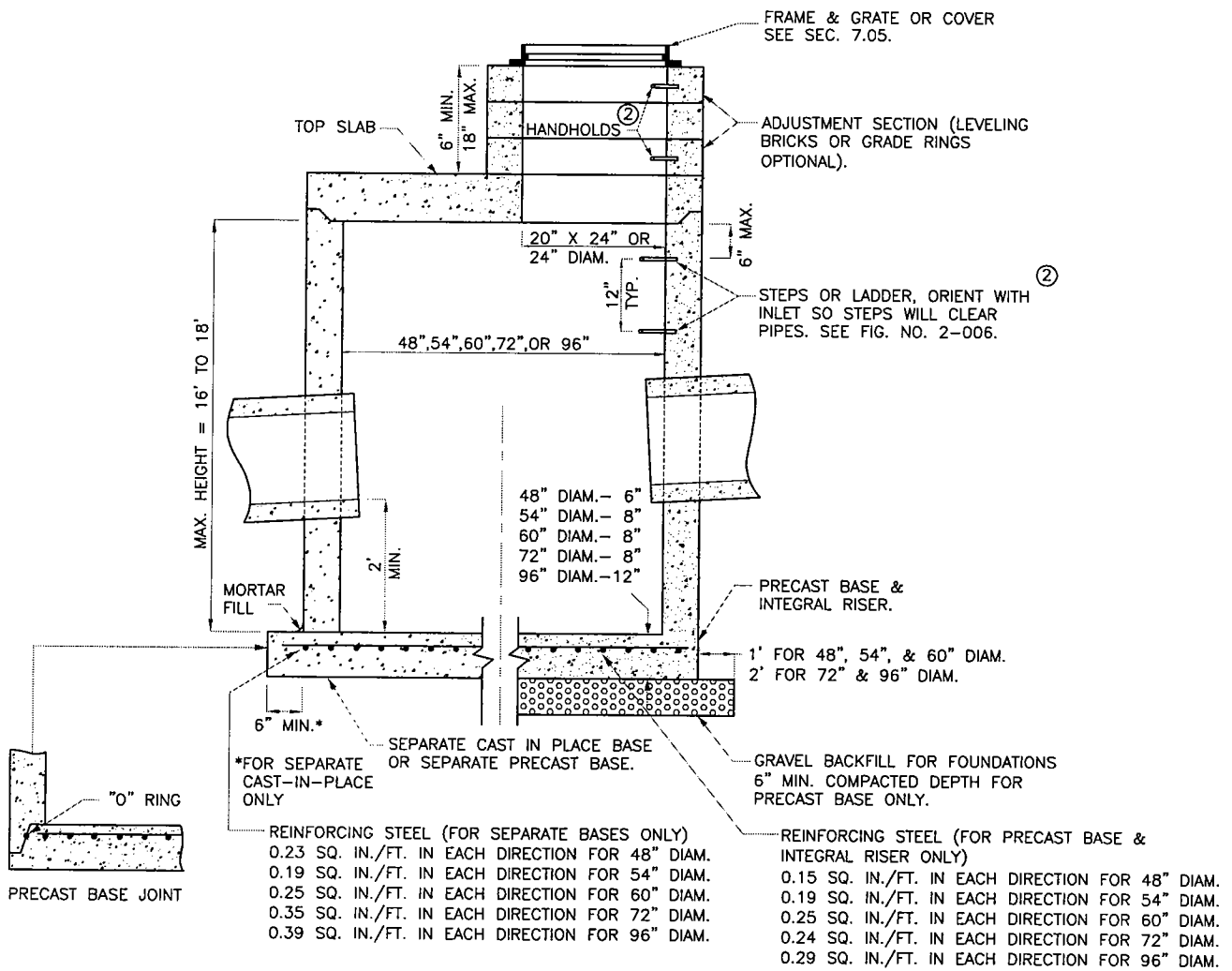

NOTES:

- CATCH BASINS SHALL BE CONSTRUCTED IN ACCORDANCE WITH ASTM C478 (AASHTO M199) AND ASTM C890 UNLESS OTHERWISE SHOWN ON PLANS OR NOTED IN THE WSDOT/APWA STANDARD SPECIFICATIONS.
- HANDHOLDS IN ADJUSTMENT SECTION SHALL HAVE 3" MIN. CLEARANCE. STEPS IN CATCH BASIN SHALL HAVE 6" MIN. CLEARANCE. SEE FIG. NO. 7-006, CATCH BASIN DETAILS. HANDHOLDS SHALL BE PLACED IN ALTERNATING GRADE RINGS OR LEVELING BRICK COURSE WITH A MIN. OF ONE HANDHOLD BETWEEN THE LAST STEP AND TOP OF THE MANHOLE.
- ALL REINFORCED CAST-IN-PLACE CONCRETE SHALL BE CLASS 4000. ALL PRECAST CONCRETE SHALL BE CLASS 4000.
- PRECAST BASES SHALL BE FURNISHED WITH CUTOUTS OR KNOCKOUTS. KNOCKOUTS SHALL HAVE WALL THICKNESS OF 2 IN. MIN. UNUSED KNOCKOUTS NEED NOT BE GROUTED IF WALL IS LEFT INTACT. PIPES SHALL BE INSTALLED ONLY IN FACTORY KNOCKOUTS UNLESS OTHERWISE APPROVED BY THE ENGINEER.
- KNOCKOUT OR CUTOUT HOLE SIZE SHALL EQUAL PIPE OUTER DIAM. PLUS CATCH BASIN WALL THICKNESS. MAX. HOLE SIZE SHALL BE 36 IN. FOR 48 IN. CATCH BASIN, 42 IN. FOR 54 IN. C.B., 48 IN. FOR 60 IN. C.B., 60 IN. FOR 72 IN. C.B., 84 IN. FOR 96 IN. C.B. MIN. DISTANCE BETWEEN HOLES SHALL BE 8 IN. FOR 48 IN., 54 IN. AND 60 IN. C.B.; 12 IN. FOR 72 IN. AND 96 IN. C.B.
- CATCH BASIN FRAMES AND GRATES OR COVERS SHALL BE IN ACCORDANCE WITH SEC. 7.05 AND MEET THE STRENGTH REQUIREMENTS OF FEDERAL SPECIFICATION RR-F-621D. MATING SURFACES SHALL BE FINISHED TO ASSURE NON-ROCKING FIT WITH ANY COVER POSITION.
- ALL BASE REINFORCING STEEL SHALL HAVE A MIN. YIELD STRENGTH OF 60,000 PSI AND BE PLACED IN THE UPPER HALF OF THE BASE WITH 1 IN. MIN. CLEARANCE.
- MIN. SOIL BEARING VALUE SHALL EQUAL 3,300 POUNDS PER SQUARE FOOT.
- FOR DETAILS SHOWING LADDER, STEPS, HANDRAILS AND TOP SLABS. SEE FIG. 7-006.
- SEE THE WSDOT/APWA STANDARD SPECIFICATIONS SEC. 7-05.3 FOR JOINT REQUIREMENTS.

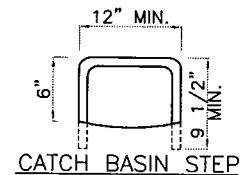
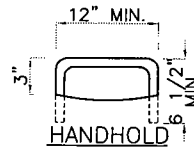
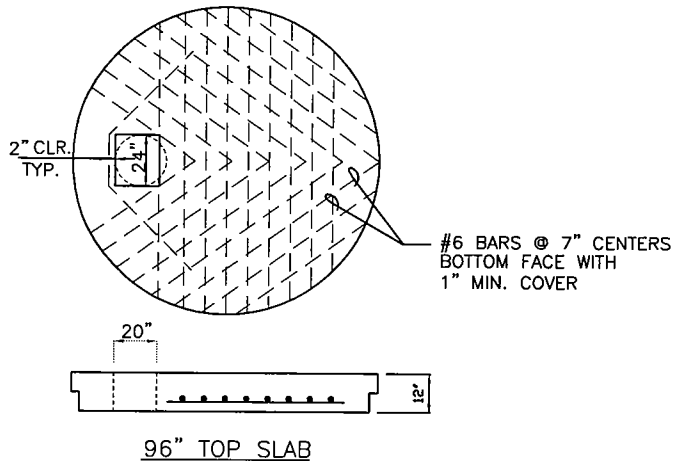
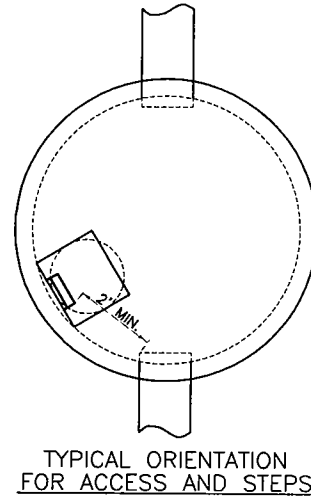
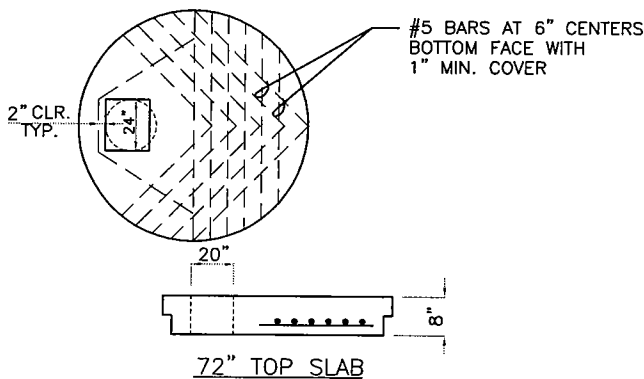
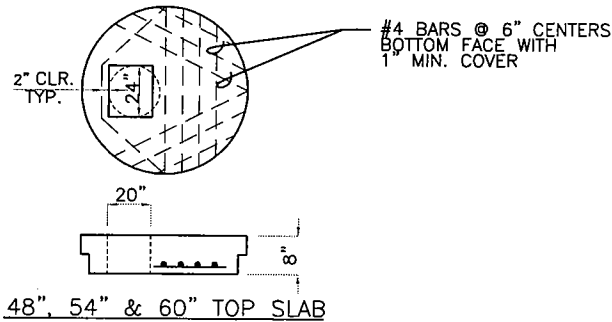
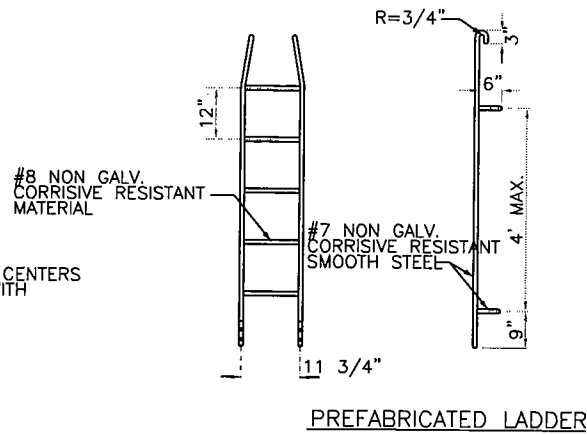
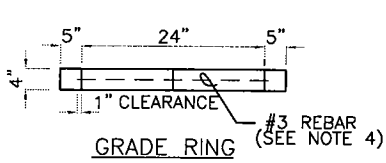

* ALL STEPS & RUNGS #8 GALV. DEFORMED REBAR OR COPOLYMER PROPYLENE.

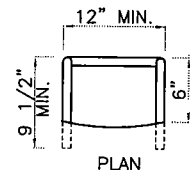
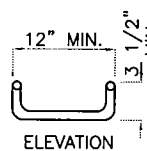

DROP RUNG CATCH BASIN STEP

NOTES:

- PROPRIETARY CATCH BASIN HANDHOLDS AND STEPS ARE ACCEPTABLE, PROVIDED THAT THEY CONFORM TO SEC. R, ASTM C478, AASHTO M-199 AND MEET ALL WISHA REQUIREMENTS.
- CATCH BASIN STEP/HANDHOLD LEGS SHALL BE PARALLEL OR APPROXIMATELY RADIAL AT THE OPTION OF THE MANUFACTURER, EXCEPT THAT ALL STEPS IN ANY CATCH BASIN SHALL BE SIMILAR. PENETRATION OF OUTER WALL BY A LEG IS PROHIBITED.
- HANDHOLDS AND STEPS SHALL HAVE "DROP" RUNGS AS SHOWN ON DETAIL OR PROTUBERANCES TO PREVENT SIDEWAYS SLIP.
- SLAB OPENING MAY BE 24" X 20" OR 24" DIAM.
- AS AN ACCEPTABLE ALTERNATIVE TO REBAR, WELDED WIRE FABRIC HAVING A MIN. AREA OF 0.12 SQ. IN. PER FT. MAY BE USED. WELDED WIRE FABRIC SHALL COMPLY TO ASTM A497.
- LADDERS OR STEPS SHALL EXTEND TO WITHIN 16 IN. OF BOTTOM OF CATCH BASIN.
- HANGING LADDERS SHALL BE PERMANENTLY FASTENED AT TOP BY HANGING ON STEP OR BY BOLTING OR EMBEDDING IN CONCRETE. EACH SHALL BE EMBEDDED AT BOTTOM IN BASE.
- ADDITIONAL SAFETY FEATURES MAY BE REQUIRED IN VERY DEEP OR UNUSUAL STRUCTURES.

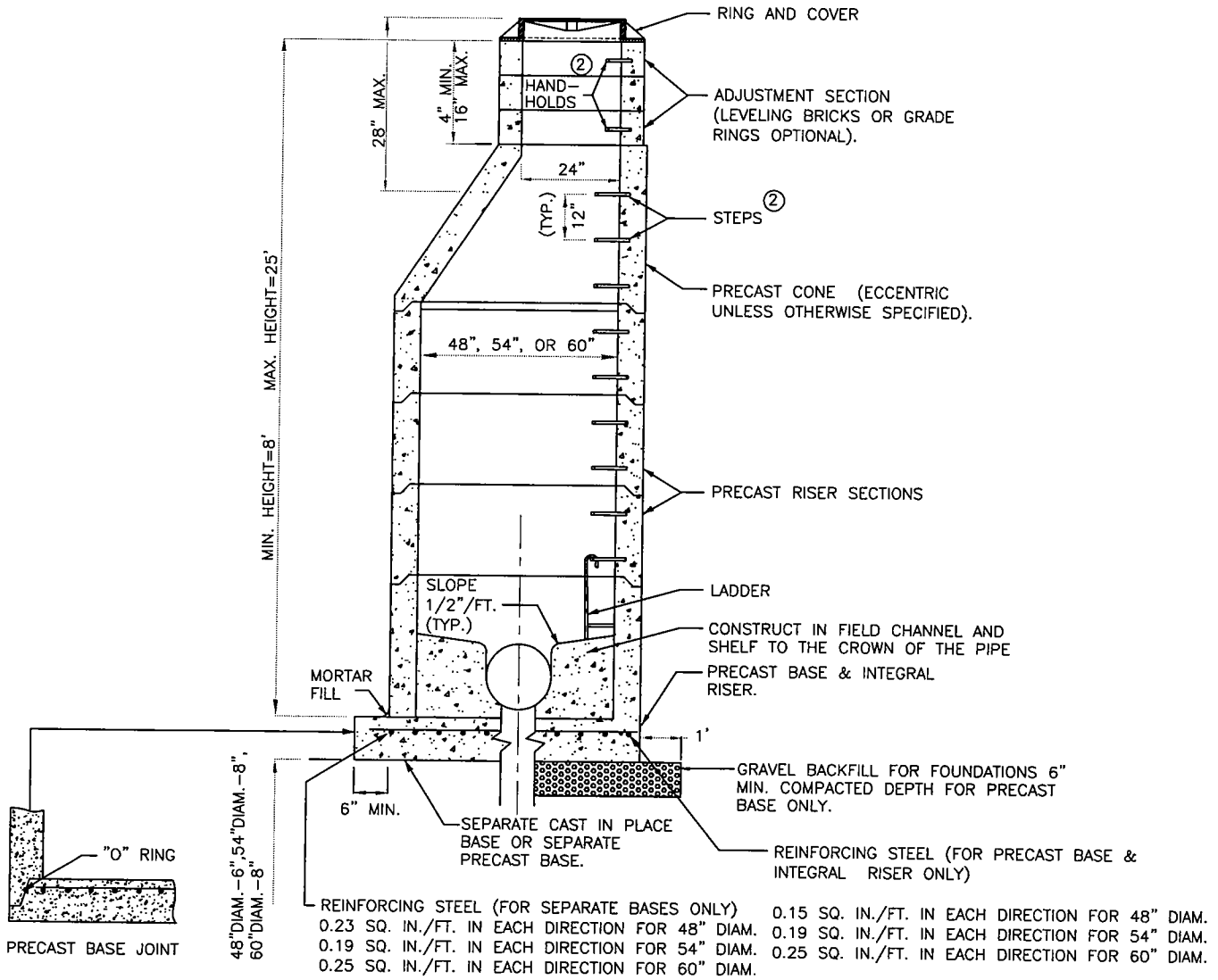

NOTES:

1. MANHOLES SHALL BE CONSTRUCTED IN ACCORDANCE WITH AASHTO M199 UNLESS OTHERWISE SHOWN ON PLANS OR NOTED IN THE WSDOT/APWA STANDARD SPECIFICATIONS.
- ② HANDHOLDS IN ADJUSTMENT SECTION SHALL HAVE 3 IN. MIN. CLEARANCE. STEPS IN MANHOLE SHALL HAVE 6 IN. MIN. CLEARANCE. SEE FIG. 7-011, "MANHOLE DETAILS." HANDHOLDS SHALL BE PLACED IN ALTERNATING GRADE RINGS OR LEVELING BRICK COURSE WITH A MIN. OF ONE HAND HOLD BETWEEN THE LAST STEP AND THE TOP OF THE MANHOLE.
3. ALL REINFORCED CAST-IN-PLACE CONCRETE SHALL BE CLASS 4000. ALL PRECAST CONCRETE SHALL BE CLASS 4000. NON-REINFORCED CONCRETE IN CHANNEL AND SHELF SHALL BE CLASS 3000.
4. PRECAST BASES SHALL BE FURNISHED WITH CUTOUTS OR KNOCKOUTS. KNOCKOUTS SHALL HAVE WALL THICKNESS OF 2 IN. MIN. UNUSED KNOCKOUTS NEED NOT BE GROUTED IF WALL IS LEFT INTACT. PIPES SHALL BE INSTALLED ONLY IN FACTORY KNOCKOUTS UNLESS OTHERWISE APPROVED BY THE ENGINEER.
5. KNOCKOUT OR CUTOUT HOLE SIZE SHALL EQUAL PIPE OUTER DIAM. PLUS MANHOLE WALL THICKNESS. MAX. HOLE SIZE SHALL BE 36 IN. FOR 48 IN. MANHOLE, 42 IN. FOR 54 IN. MANHOLE, 48 IN. FOR 60 IN. M.H. MIN. DISTANCE BETWEEN HOLES SHALL BE 8 IN.
6. MANHOLE RINGS AND COVERS SHALL BE IN ACCORDANCE WITH SEC. 7.05 AND MEET THE STRENGTH REQUIREMENTS OF FEDERAL SPECIFICATION RR-F-621D. MATING SURFACES SHALL BE FINISHED TO ASSURE NON-ROCKING FIT WITH ANY COVER POSITION.
7. ALL BASE REINFORCING STEEL SHALL HAVE A MIN. YIELD STRENGTH OF 60,000 PSI AND BE PLACED IN THE UPPER HALF OF THE BASE WITH 1 IN. MIN. CLEARANCE.
8. FOR HEIGHTS OF 12 FT. OR LESS, MIN. SOIL BEARING VALUE SHALL EQUAL 3,300 LBS. PER SQ. FT. FOR HEIGHTS OVER 12 FT. MIN. SOIL BEARING VALUE SHALL EQUAL 3,800 LBS. PER SQ. FT.
9. FOR DETAILS SHOWING GRADE RING, LADDER, STEPS, HANDHOLDS, AND TOP SLABS, SEE FIG. 7-011, "MANHOLE DETAILS."
10. SEE THE WSDOT/APWA STANDARD SPECIFICATIONS SEC. 7-05.3 FOR JOINT REQUIREMENTS.

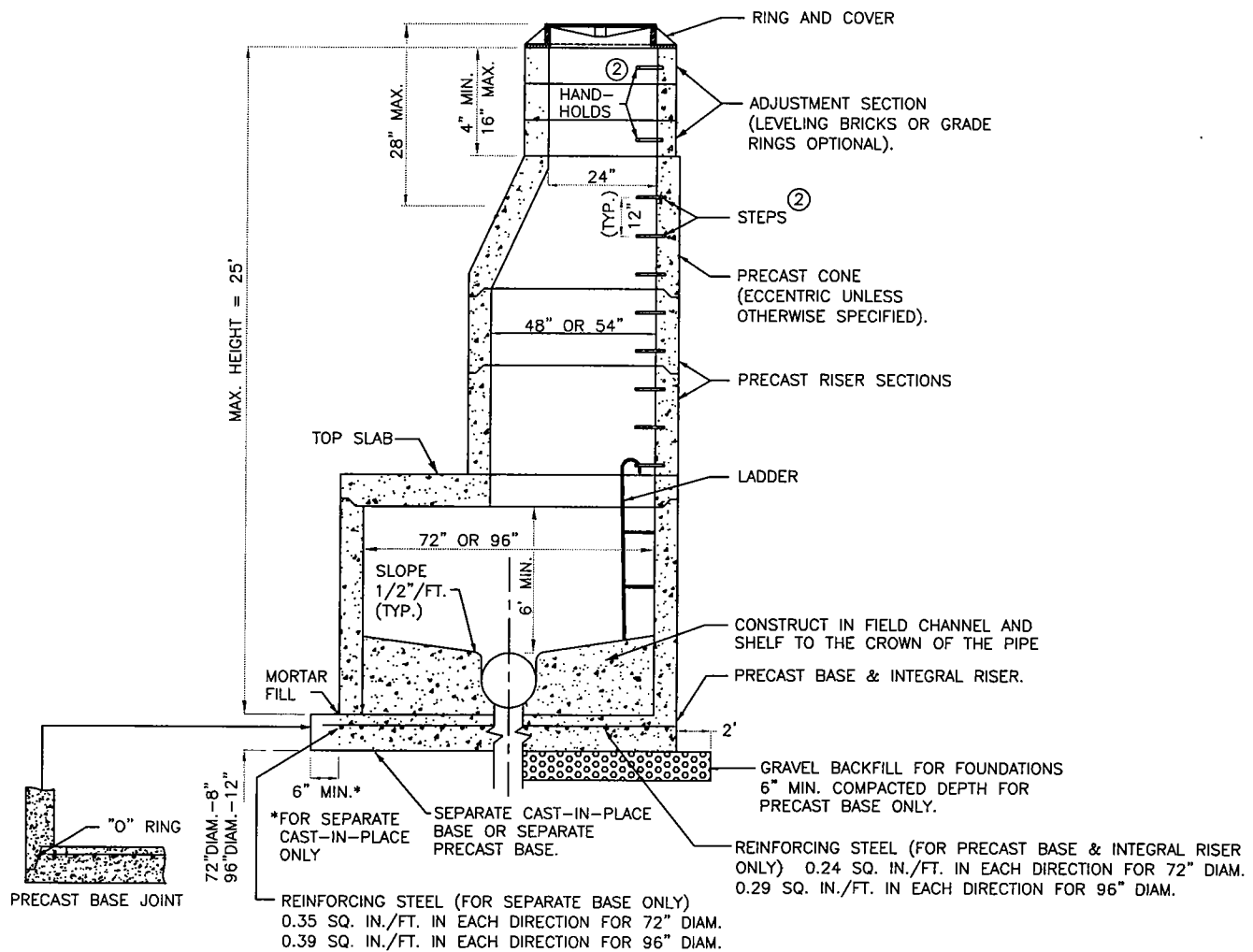

NOTES:

1. MANHOLES SHALL BE CONSTRUCTED IN ACCORDANCE WITH AASHTO M199 UNLESS OTHERWISE SHOWN ON PLANS OR NOTED IN THE WSDOT/APWA STANDARD SPECIFICATIONS.
- ② HANDHOLDS IN ADJUSTMENT SECTION SHALL HAVE 3 IN. MIN. CLEARANCE. STEPS IN MANHOLE SHALL HAVE 6 IN. MIN. CLEARANCE. SEE FIG. 7-011, "MANHOLE DETAILS." HANDHOLDS SHALL BE PLACED IN ALTERNATING GRADE RINGS OR LEVELING BRICK COURSE WITH MIN. OF ONE HANDHOLD BETWEEN THE LAST STEP AND THE TOP OF THE MANHOLE.
3. ALL REINFORCED CAST-IN-PLACE CONCRETE SHALL BE CLASS 4000. NON-REINFORCED CONCRETE IN CHANNEL AND SHELF SHALL BE CLASS 3000. ALL PRECAST CONCRETE SHALL BE CLASS 4000.
4. PRECAST BASES SHALL BE FURNISHED WITH CUTOUTS OR KNOCKOUTS. KNOCKOUTS SHALL HAVE WALL THICKNESS OF 2 IN. MIN. UNUSED KNOCKOUTS NEED NOT BE GROUTED IF WALL IS LEFT INTACT. PIPES SHALL BE INSTALLED ONLY IN FACTORY KNOCKOUTS UNLESS OTHERWISE APPROVED BY THE ENGINEER.
5. KNOCKOUT OR CUTOUT HOLE SIZE SHALL EQUAL PIPE OUTER DIAM. PLUS MANHOLE WALL THICKNESS. MAX. HOLE SIZE SHALL BE 60 IN. FOR 72 IN. MANHOLE, 84 IN. FOR 96 IN. MANHOLE. MIN. DISTANCE BETWEEN HOLES SHALL BE 12 IN.
6. MANHOLE RINGS AND COVERS SHALL BE IN ACCORDANCE WITH SEC. 7.05 AND MEET THE STRENGTH REQUIREMENTS OF FEDERAL SPECIFICATION RR-F-621D. MATING SURFACES SHALL BE FINISHED TO ASSURE NON-ROCKING FIT WITH ANY COVER POSITION.
7. ALL BASE REINFORCING STEEL SHALL HAVE A MIN. YIELD STRENGTH OF 60,000 PSI AND BE PLACED IN THE UPPER HALF OF THE BASE WITH 1 IN. MIN. CLEARANCE.
8. FOR HEIGHTS OF 12 FT. OR LESS, MIN. SOIL BEARING VALUE SHALL EQUAL 3,300 POUNDS PER SQUARE FOOT. FOR HEIGHTS OVER 12', MIN. SOIL BEARING VALUE SHALL EQUAL 3,800 POUNDS PER SQUARE FOOT.
9. FOR DETAILS SHOWING GRADE RING, LADDER, STEPS, HANDHOLDS, AND TOP SLABS, SEE FIG. 7-011, "MANHOLE DETAILS."
10. SEE THE WSDOT/APWA STANDARD SPECIFICATIONS SEC. 7-05.3 FOR JOINT REQUIREMENTS.

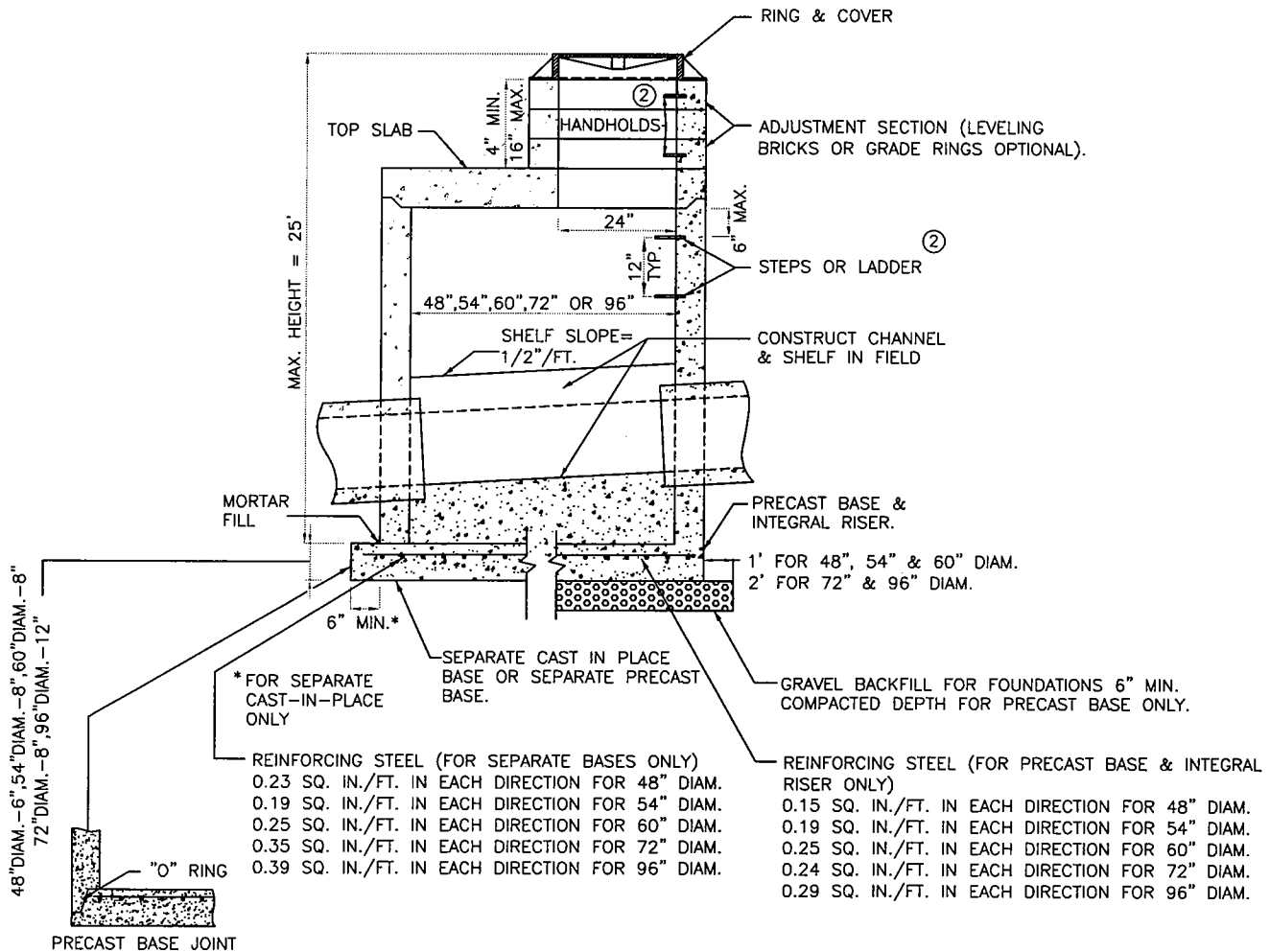

NOTES:

- MANHOLES SHALL BE CONSTRUCTED IN ACCORDANCE WITH AASHTO M199 UNLESS OTHERWISE SHOWN ON PLANS OR NOTED IN THE WSDOT/APWA STANDARD SPECIFICATIONS.
- HANDHOLDS IN ADJUSTMENT SECTION SHALL HAVE 3 IN. MIN. CLEARANCE. STEPS IN MANHOLE SHALL HAVE 6 IN. MIN. CLEARANCE. SEE FIG. 2-011, "MANHOLE DETAILS." HANDHOLDS SHALL BE PLACED IN ALTERNATING GRADE RINGS OR LEVELING BRICK COURSE WITH A MIN. OF ONE HANDHOLD BETWEEN THE LAST STEP AND THE TOP OF THE MANHOLE.
- ALL REINFORCED CAST-IN-PLACE CONCRETE SHALL BE CLASS 4000. NON-REINFORCED CONCRETE IN CHANNEL AND SHELF SHALL BE CLASS 3000. ALL PRECAST CONCRETE SHALL BE CLASS 4000.
- PRECAST BASES SHALL BE FURNISHED WITH CUTOUTS OR KNOCKOUTS. KNOCKOUTS SHALL HAVE WALL THICKNESS OF 2 IN. MIN. UNUSED KNOCKOUTS NEED NOT BE GROUDED IF WALL IS LEFT INTACT. PIPES SHALL BE INSTALLED ONLY IN FACTORY KNOCKOUTS UNLESS OTHERWISE APPROVED BY THE ENGINEER.
- KNOCKOUT OR CUTOUT HOLE SIZE SHALL EQUAL PIPE OUTER DIAM. PLUS MANHOLE WALL THICKNESS. MAX. HOLE SIZE SHALL BE 36 IN. FOR 48 IN. M.H., 42 IN. FOR 54 IN. M.H., 48 IN. FOR 60 IN. M.H., 60 IN. FOR 72 IN. M.H., 84 IN. FOR 96 IN. M.H. MIN. DISTANCE BETWEEN HOLES SHALL BE 8 IN. FOR 48 IN., 54 IN., AND 60 IN. M.H. 12 IN. FOR 72 IN. AND 96 IN. M.H.
- MANHOLE RINGS AND COVERS SHALL BE IN ACCORDANCE WITH SEC. 7.05 AND MEET THE STRENGTH REQUIREMENTS OF FEDERAL SPECIFICATION RR-F-621D. MATING SURFACES SHALL BE FINISHED TO ASSURE NON-ROCKING FIT WITH ANY COVER POSITION.
- ALL BASE REINFORCING STEEL SHALL HAVE A MIN. YIELD STRENGTH OF 60,000 PSI AND BE PLACED IN THE UPPER HALF OF THE BASE WITH 1 IN. MIN. CLEARANCE.
- FOR HEIGHTS OF 12 FT. OR LESS, MIN. SOIL BEARING VALUE SHALL EQUAL 3,300 LBS. PER SQ. FT. FOR HEIGHTS OVER 12 FT., MIN. SOIL BEARING VALUE SHALL EQUAL 3,800 LBS. PER SQ. FT.
- FOR DETAILS SHOWING GRADE RING, LADDER, STEPS, HANDHOLDS, AND TOP SLABS, SEE FIG. 7-011, "MANHOLE DETAILS."
- SEE THE WSDOT/APWA STANDARD SPECIFICATIONS SEC. 7-05.3 FOR JOINT REQUIREMENTS.

MANHOLE TYPE 3
48", 54", 60", 72", AND 96"

FIG. 7-009

7-14

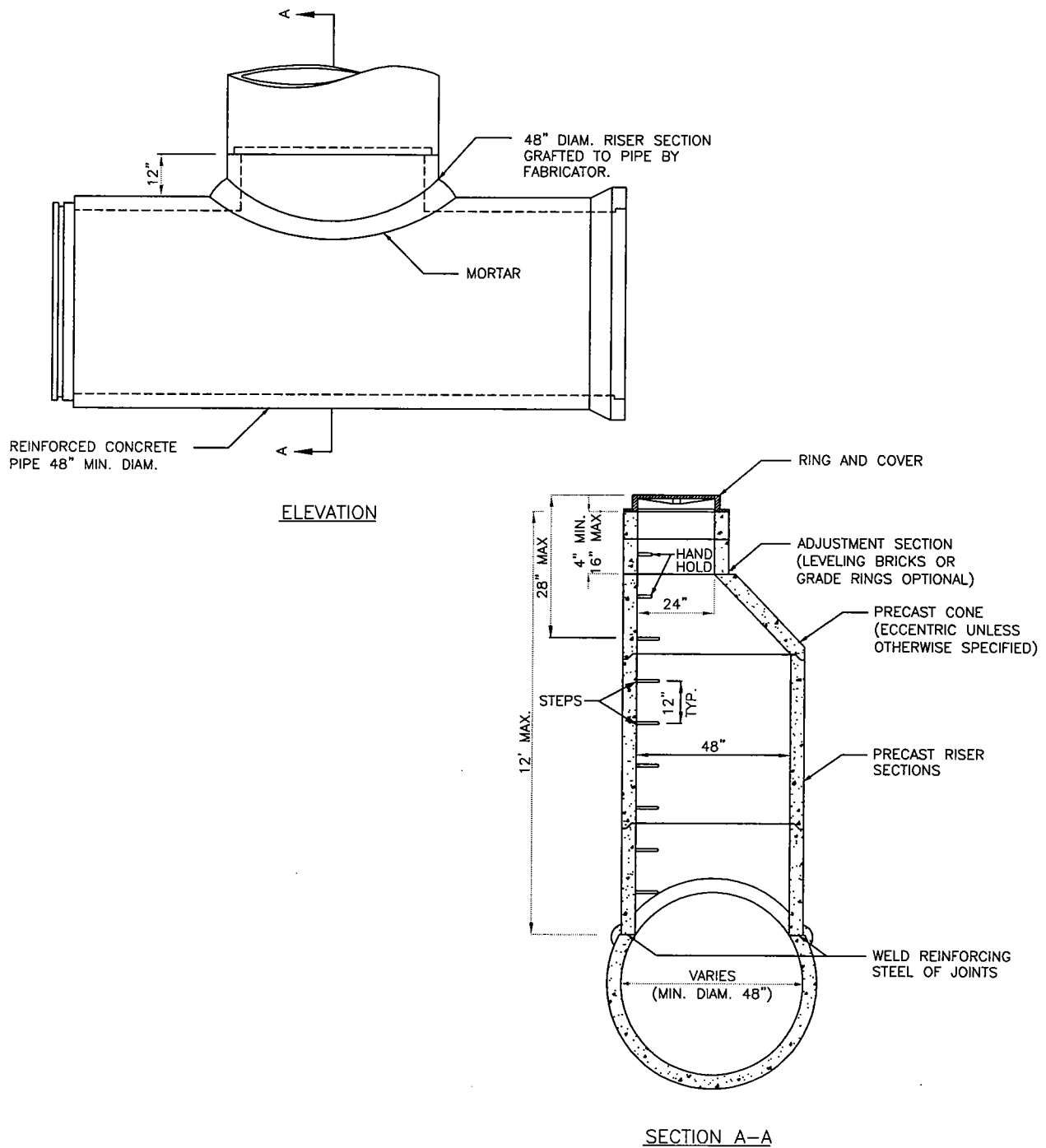

NOTES:

1. MANHOLES SHALL BE CONSTRUCTED IN ACCORDANCE WITH AASHTO M199 UNLESS OTHERWISE SHOWN ON PLANS OR NOTED IN THE WSDOT/APWA STANDARD SPECIFICATIONS.
2. HANDHOLDS IN ADJUSTMENT SECTION SHALL HAVE 3 IN. MIN. CLEARANCE. STEPS IN MANHOLE SHALL HAVE 6 IN. MIN. CLEARANCE. SEE FIG. 7-011, "MANHOLE DETAILS."
3. MANHOLE RINGS AND COVERS SHALL BE IN ACCORDANCE WITH SEC. 7.05 AND MEET THE STRENGTH REQUIREMENTS OF FEDERAL SPECIFICATION RR-F-621D. MATING SURFACES SHALL BE FINISHED TO ASSURE NON-ROCKING FIT WITH ANY COVER POSITION.
4. ALL PRECAST CONCRETE SHALL BE CLASS 4000.
5. FOR DETAILS SHOWING GRADE RING, LADDER, STEPS, HANDHOLDS, AND TOP SLABS, SEE FIG. 7-011, "MANHOLE DETAILS".
6. NOT FOR USE IN TRAFFIC BEARING AREAS.

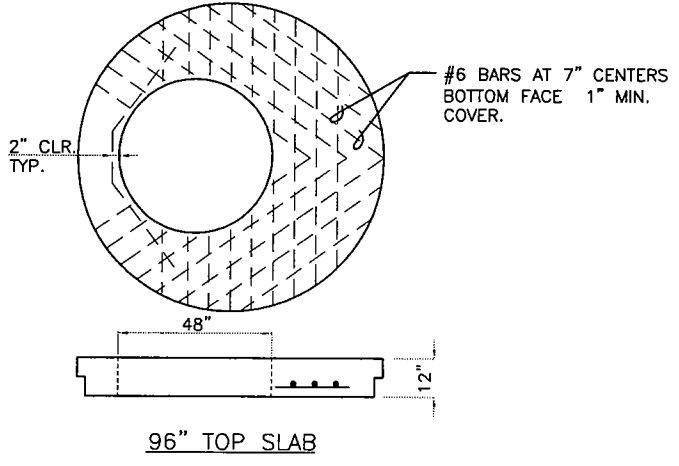
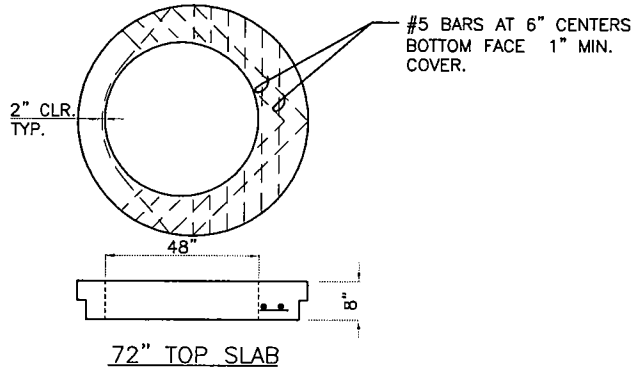
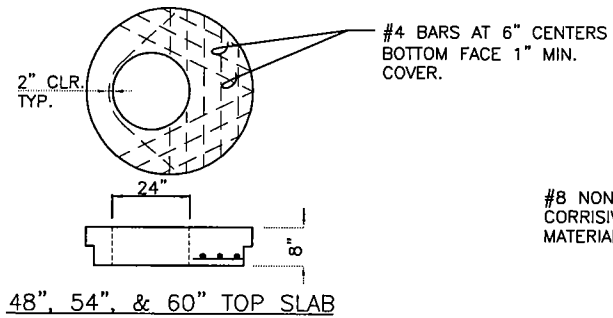

NOTES:

1. PROPRIETARY MANHOLE HANDHOLDS AND STEPS ARE ACCEPTABLE, PROVIDED THAT THEY CONFORM TO SEC. R, ASTM C478, AASHTO M199 AND MEET ALL WISHA REQUIREMENTS.
2. MANHOLE STEP/HANDHOLD LEGS SHALL BE PARALLEL OR APPROXIMATELY RADIAL AT THE OPTION OF THE MANUFACTURER, EXCEPT THAT ALL STEPS IN ANY MANHOLE SHALL BE SIMILAR. PENETRATION OF OUTER WALL BY A LEG IS PROHIBITED.
3. HANDHOLDS AND STEPS SHALL HAVE "DROP" RUNGS OR PROTUBERANCES TO PREVENT SIDEWAYS SLIP.
4. LADDERS OR STEPS SHALL EXTEND TO WITHIN 16" OF BOTTOM OF MANHOLE.
5. HANGING LADDERS SHALL BE PERMANENTLY FASTENED AT TOP BY HANGING ON STEP OR BY BOLTING OR EMBEDDING IN CONCRETE. EACH SHALL BE EMBEDDED AT BOTTOM IN BASE.
6. ADDITIONAL SAFETY FEATURES MAY BE REQUIRED IN VERY DEEP OR UNUSUAL STRUCTURES.

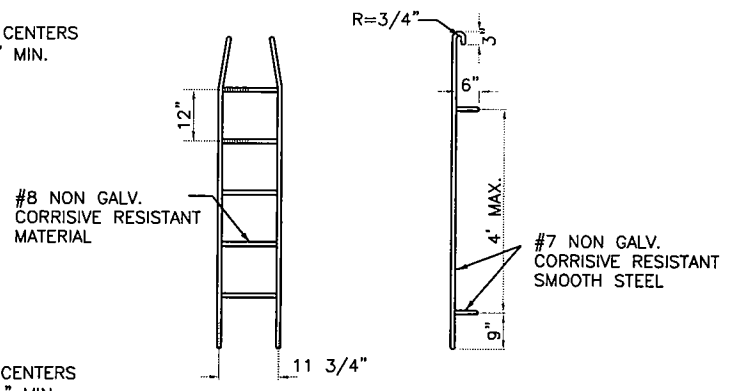

PREFABRICATED LADDER

* ALL STEPS & RUNGS
1" DIAM. GALV. REBAR OR
COPOLYMER PROPYLENE.

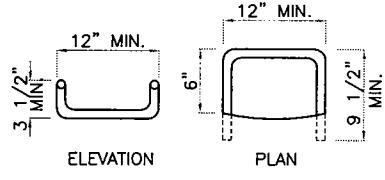
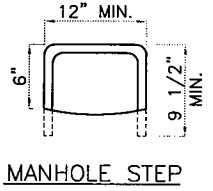
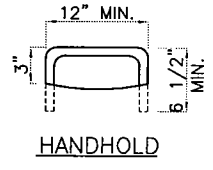

MANHOLE DROP RUNG STEP

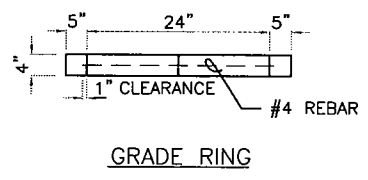

FRAME AND GRATE
SEE SEC. 7.05 AND
APPLICABLE
DETAILS.

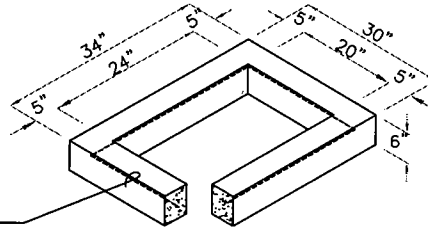
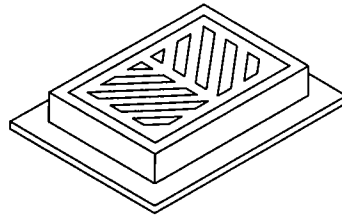

6" RISER SECTION

1 #3 BAR HOOP

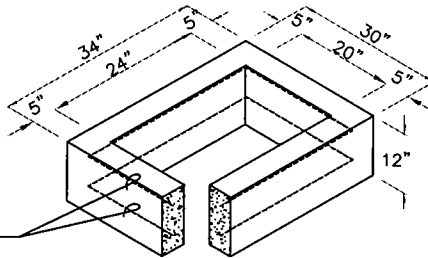

12" RISER SECTION

2 #3 BAR HOOPS

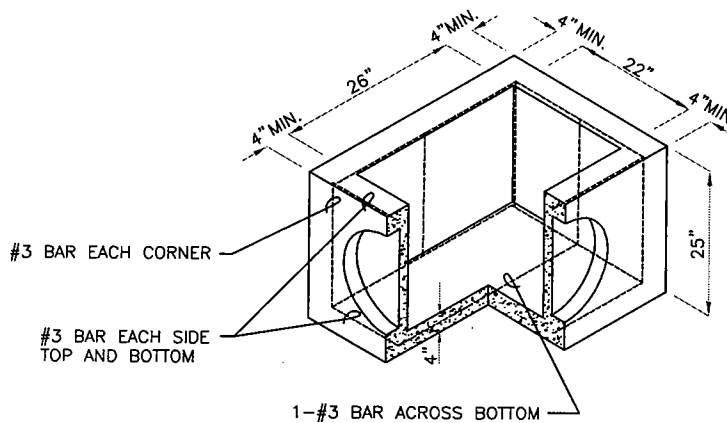

PRECAST BASE SECTION
(MEASUREMENT AT THE
TOP OF THE BASE)

#3 BAR EACH CORNER

#3 BAR EACH SIDE
TOP AND BOTTOM

1-#3 BAR ACROSS BOTTOM

NOTES:

1. CURB INLET TO BE CONSTRUCTED IN ACCORDANCE WITH ASTM C478 & C890 UNLESS OTHERWISE SHOWN ON PLANS OR NOTED IN THE STANDARD SPECIFICATIONS.
2. AS AN ACCEPTABLE ALTERNATIVE TO REBAR, WELDED WIRE FABRIC HAVING A MIN. AREA OF 0.12 SQ. IN. PER FT. MAY BE USED. WELDED WIRE FABRIC SHALL COMPLY TO ASTM A497. WIRE FABRIC SHALL NOT BE PLACED IN KNOCKOUTS.
3. ALL REINFORCED CAST-IN-PLACE CONCRETE SHALL BE CLASS 4000.
4. PRECAST BASES SHALL BE FURNISHED WITH CUTOUTS OR KNOCKOUTS. KNOCKOUTS SHALL HAVE A WALL THICKNESS OF 2" MIN. ALL PIPE SHALL BE INSTALLED IN FACTORY PROVIDED KNOCKOUTS. UNUSED KNOCKOUTS NEED NOT BE GROUTED IF WALL IS LEFT INTACT.
5. KNOCKOUT OR CUTOUT HOLE SIZE IS EQUAL TO PIPE OUTER DIAM. PLUS CURB INLET WALL THICKNESS.
6. ROUND KNOCKOUTS MAY BE ON ALL 4 SIDES WITH MAX. DIAM. OF 17 IN..
7. THE MAX. DEPTH FROM THE FINISHED GRADE TO THE PIPE INVERT IS 5 FT.
8. THE TAPER ON THE SIDES OF THE PRECAST BASE SECTION AND RISER SECTION SHALL NOT EXCEED 1/2 IN. PER FT.
9. CONCRETE INLET FRAME AND GRATES SHALL BE IN ACCORDANCE WITH STANDARD SPECIFICATIONS AND MEET THE STRENGTH REQUIREMENTS OF FEDERAL SPECIFICATION RR-F-621D. MATING SURFACES SHALL BE FINISHED TO ASSURE NON-ROCKING FIT WITH ANY OTHER COVER POSITION.
10. FRAME AND GRATE MAY BE INSTALLED WITH FLANGE DOWN OR CAST INTO RISER.

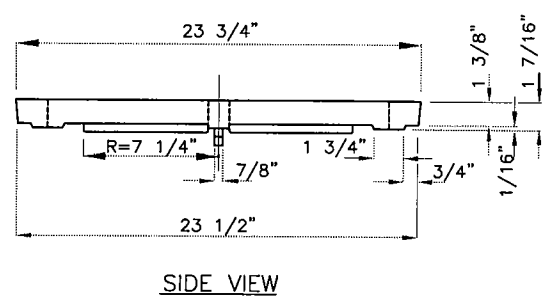
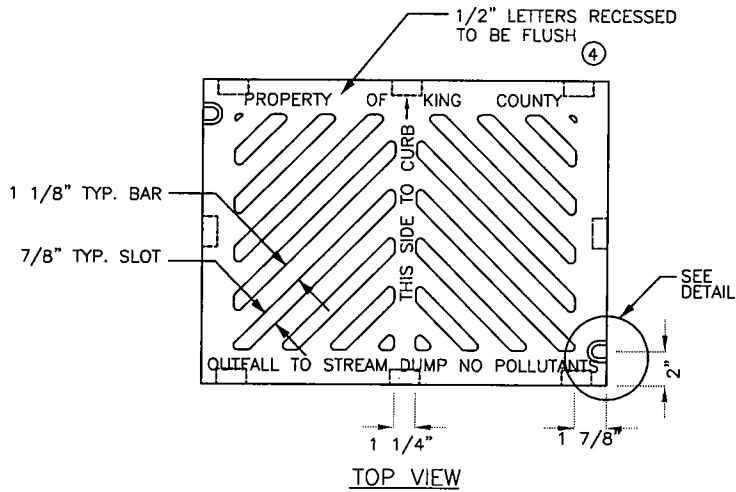

SIDE VIEW

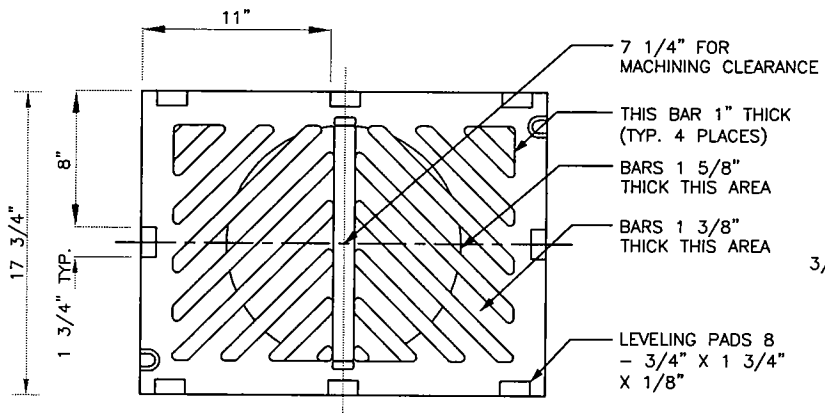

BOTTOM VIEW

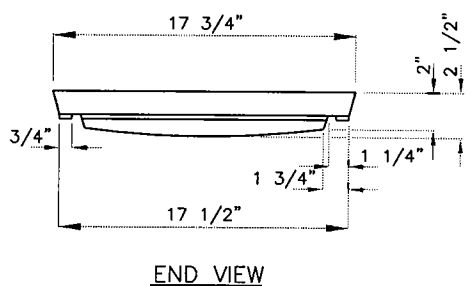

END VIEW

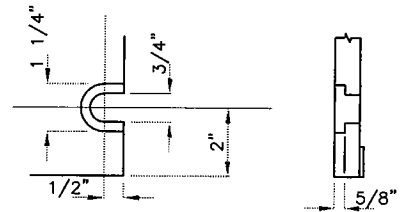

SLOT DETAIL
SEE NOTE 1

NOTES:

1. SLOT FORMED AND RECESSED FOR 5/8 IN.-11 NC X 2 IN. SOCKET HEAD (ALLEN HEAD) CAP SCREW.
2. GRATE SHALL BE CAST IRON PER ASTM A48 CLASS 30 UNLESS OTHERWISE SPECIFIED.
3. SEE SEC. 7.05.
- ④ THE WORDS "PROPERTY OF KING COUNTY" SHALL BE OMITTED IF GRATE IS ON PRIVATE SYSTEM.
5. GRATES SHALL BE MIN 32 IN. CLEAR OF WHERE WHEELCHAIR RAMPS ARE FLUSH WITH PAVEMENT.

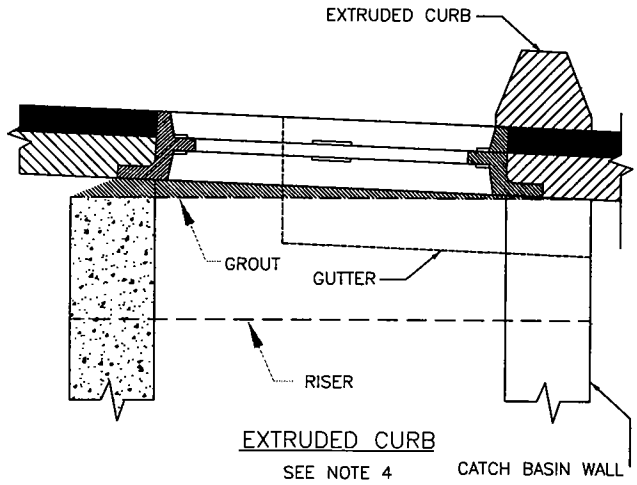
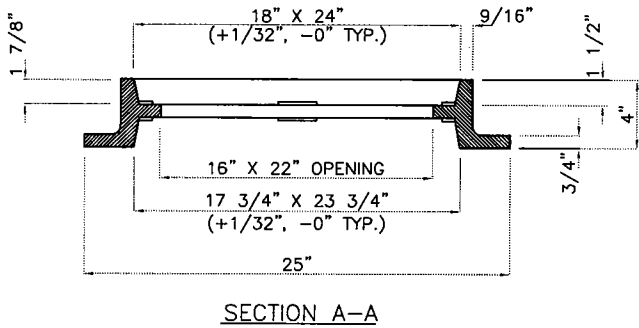
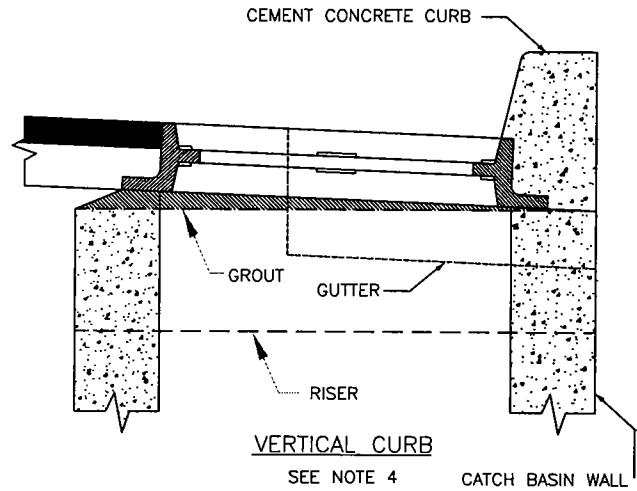
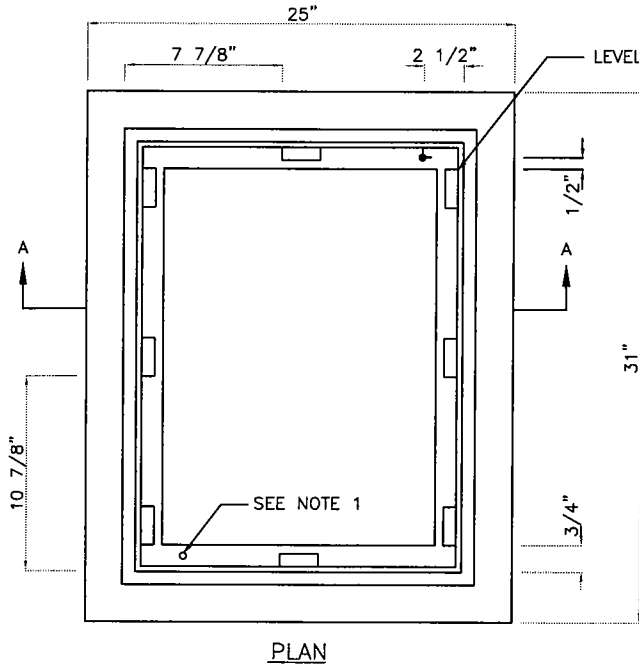

NOTES:

1. DRILL AND TAP FOR, AND PROVIDE, TWO LOCKING BOLTS 5/8 IN.-11 NC STAINLESS TYPE 304 STEEL SOCKET HEAD (ALLEN HEAD) CAP SCREWS 2 IN. LONG WHEN USED WITH SOLID COVER (FIG. 7-015) OR WHEN SPECIFIED BY ENGINEER.
2. FRAME MATERIAL IS DUCTILE IRON PER ASTM A48 CLASS 30.
3. SET FRAME TO GRADE AND CONSTRUCT ROAD AND GUTTER TO BE FLUSH WITH FRAME.
4. SEE SEC. 7.05.

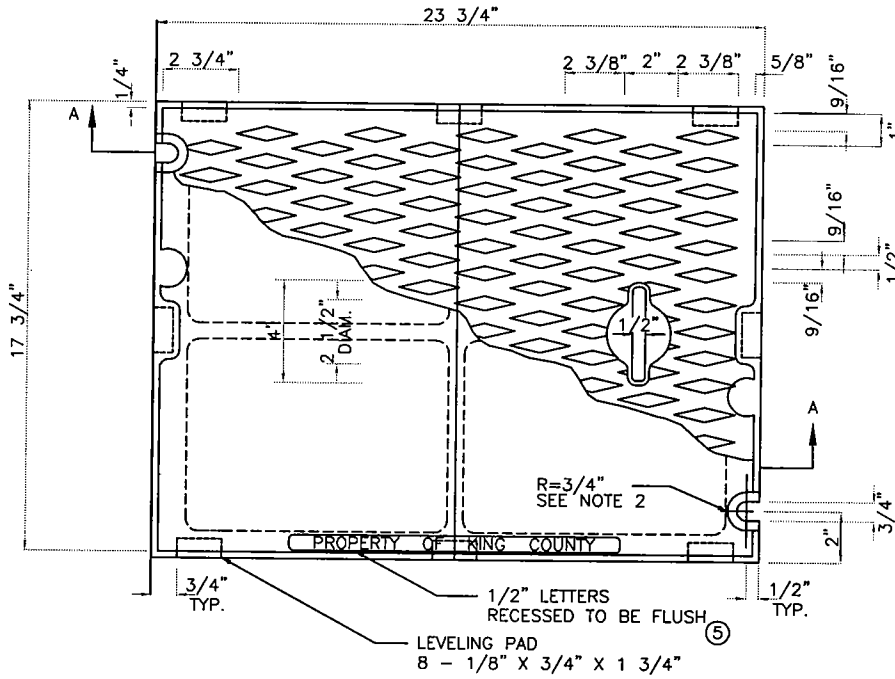

PLAN COVER

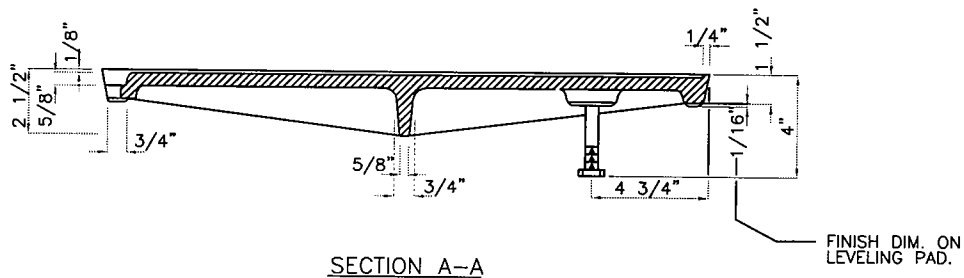

SECTION A-A

NOTES:

1. USE WITH FRAME (FIG. 7-014) DRILLED AND TAPPED FOR LOCKING BOLTS.
2. USE WITH TWO LOCKING BOLTS 5/8 IN.-11 NC STAINLESS STEEL TYPE 304 STEEL SOCKET HEAD (ALLEN HEAD) CAP SCREWS, MIN. 2 IN. LONG.
3. MATERIAL IS CAST IRON PER ASTM A48 CLASS 30.
4. SEE SEC. 7.05.
- ⑤ THE WORDS "PROPERTY OF KING COUNTY" SHALL BE OMITTED IF COVER IS ON A PRIVATE SYSTEM.

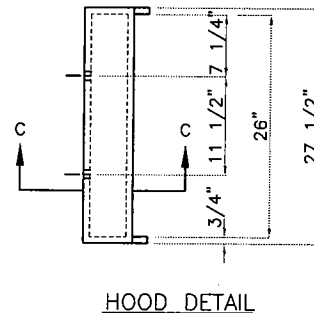
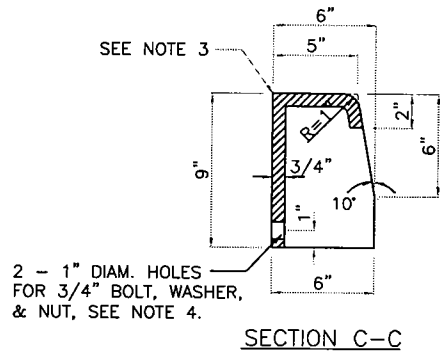
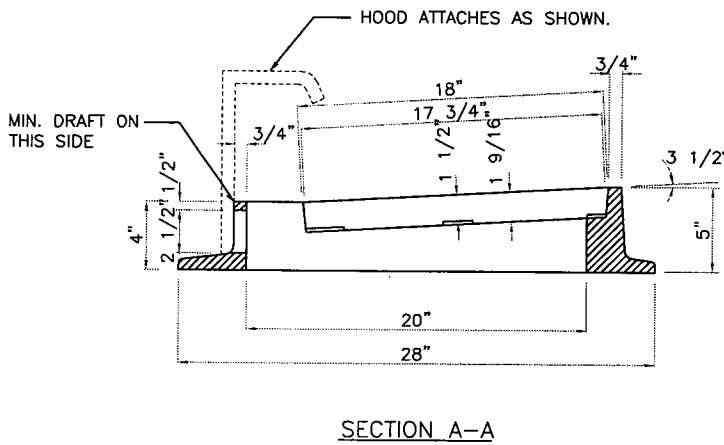
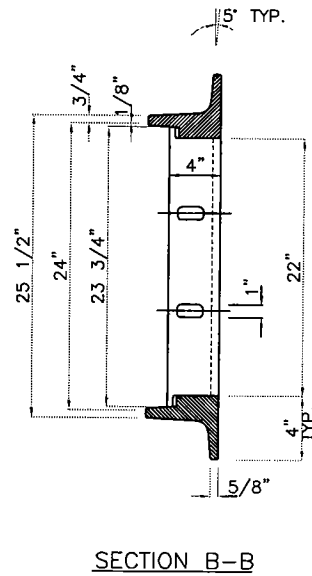
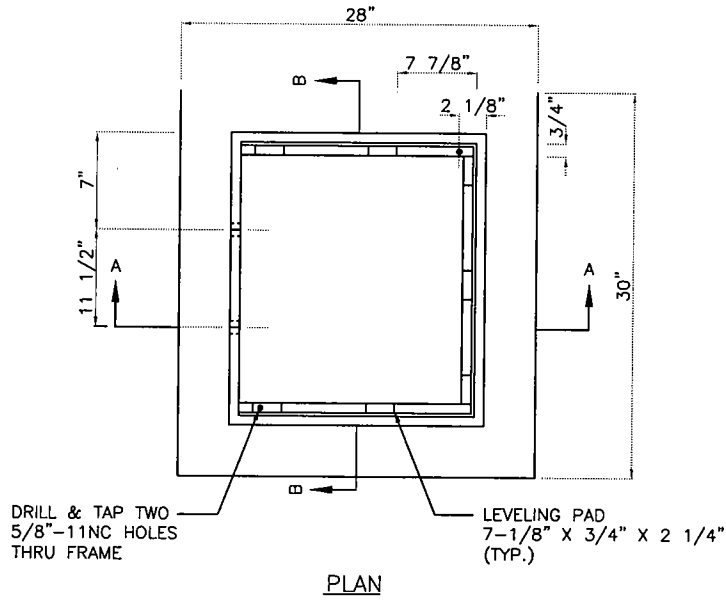

NOTES:

1. MATERIAL IS CAST IRON ASTM A48 CLASS 30.
2. SEE FIG. 7-018 FOR VANED GRATE.
3. PATTERN ON TOP SURFACE OF HOOD SHALL BE 3/16 IN. NON-SKID DIAMOND.
4. BOLT, WASHER, AND NUT SHALL BE GALV. OR CORROSION RESISTANT.
5. SEE SEC. 7.05.

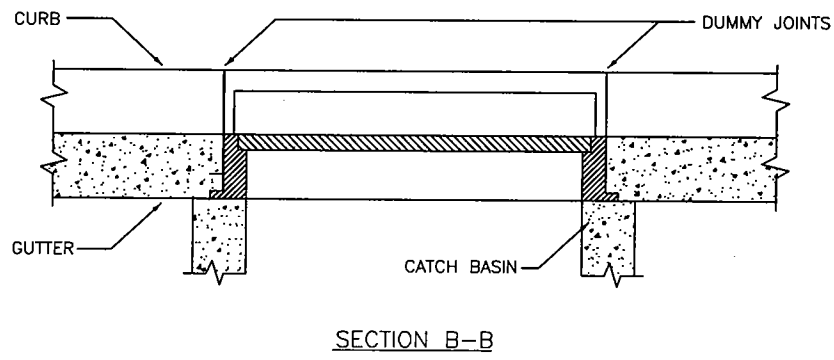
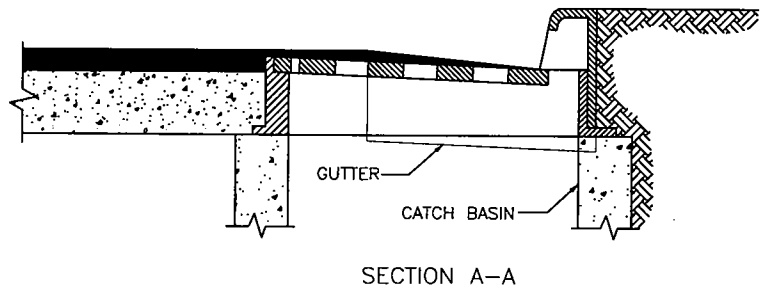
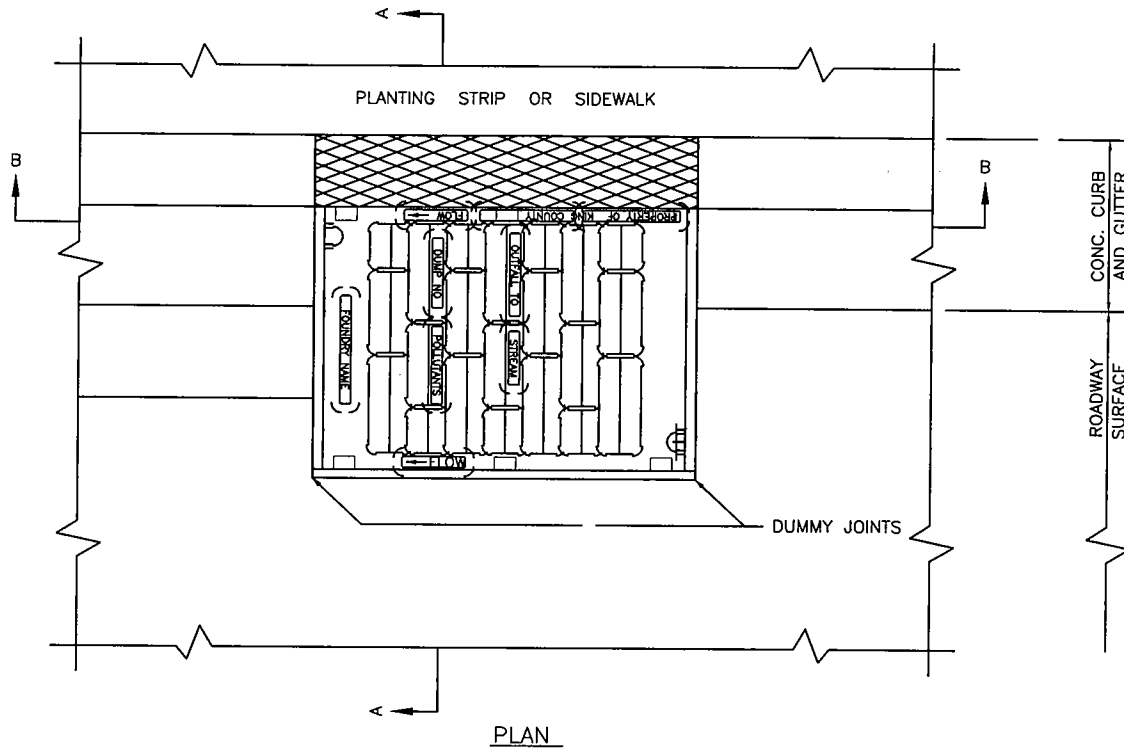

NOTES:

1. SET TO GRADE AND CONSTRUCT ROAD AND GUTTER TO BE FLUSH WITH FRAME.
2. SEE SEC. 3.04 FOR JOINT REQUIREMENTS.

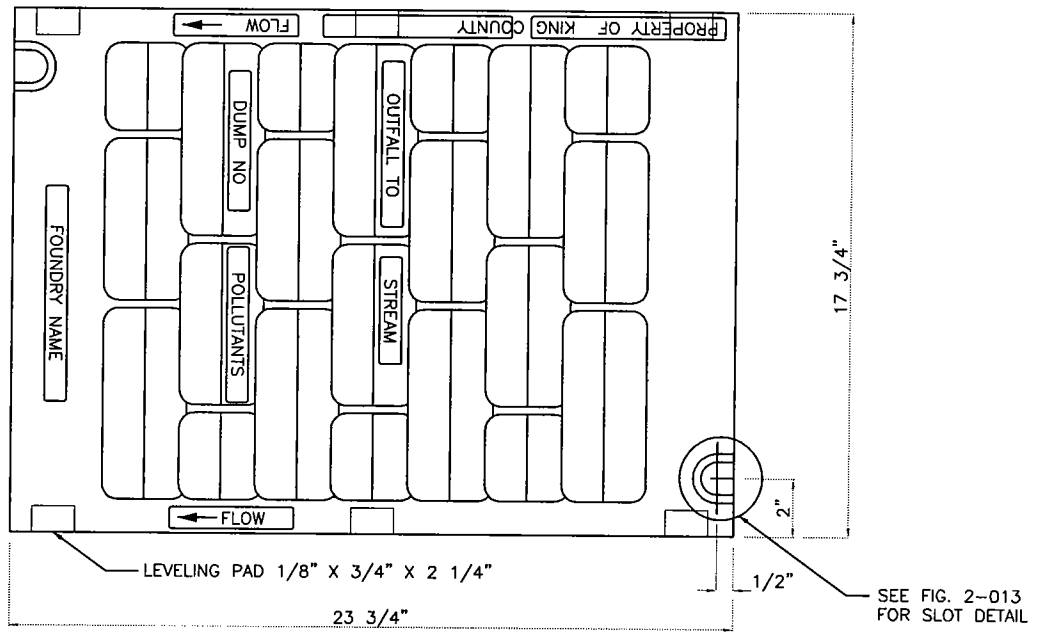

PLAN

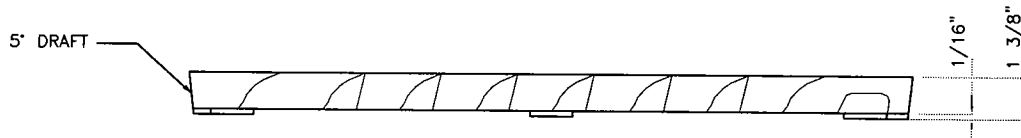

ELEVATION

NOTES:

1. SELF-LOCK VANED GRATE MANUFACTURER SUBJECT TO APPROVAL BY ENGINEER.
2. USE WITH TWO LOCKING BOLTS 5/8 IN.-11 NC STAINLESS TYPE 304 STEEL SOCKET HEAD (ALLEN HEAD) CAP SCREWS 2 IN. LONG. NOTE SLOT DETAIL.
3. MATERIAL IS DUCTILE IRON ASTM A536 GRADE 80-55-06.
4. "OUTFALL TO STREAM DUMP NO POLLUTANTS" MAY BE LOCATED ON BORDER AREA.
5. SEE SEC. 7.05.
6. THE WORDS "PROPERTY OF KING COUNTY" SHALL BE OMITTED IF GRATE IS ON PRIVATE SYSTEM.

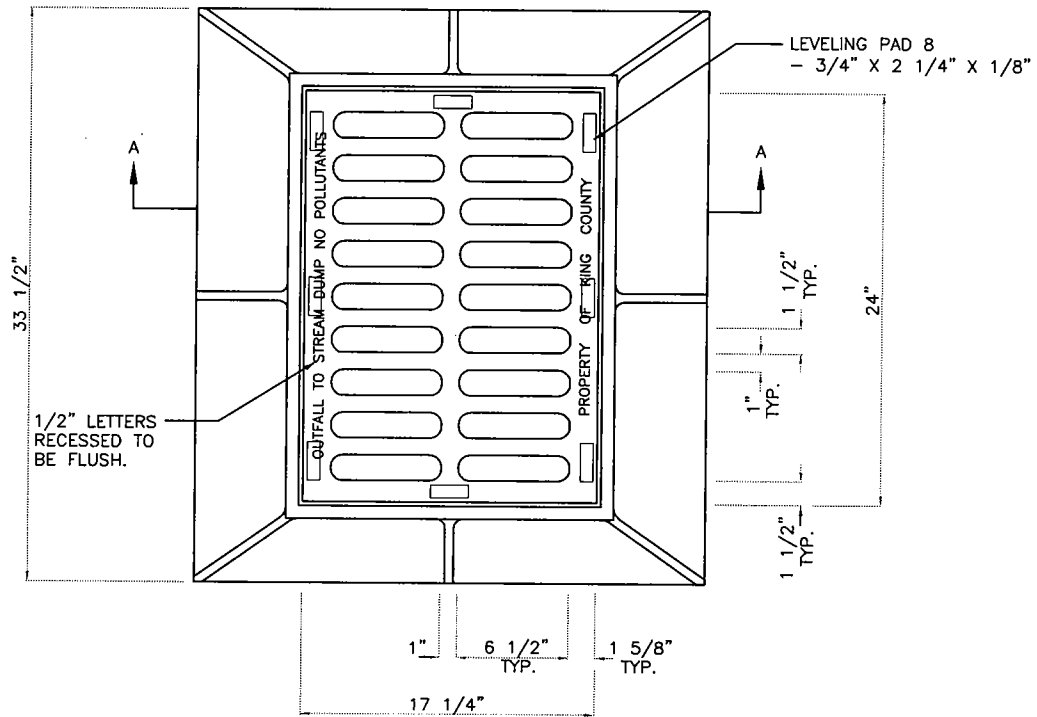

PLAN

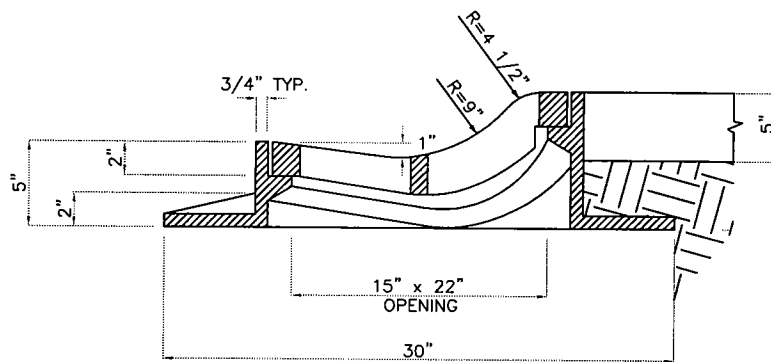

SECTION A-A

NOTES:

1. MATERIAL IS CAST IRON ASTM A48 CLASS 30.
2. SEE SEC. 7.05.
3. THE WORDS "PROPERTY OF KING COUNTY" SHALL BE OMITTED IF ON A PRIVATE SYSTEM.
4. NOT TO BE USED ON THICKENED EDGE ROADWAYS.

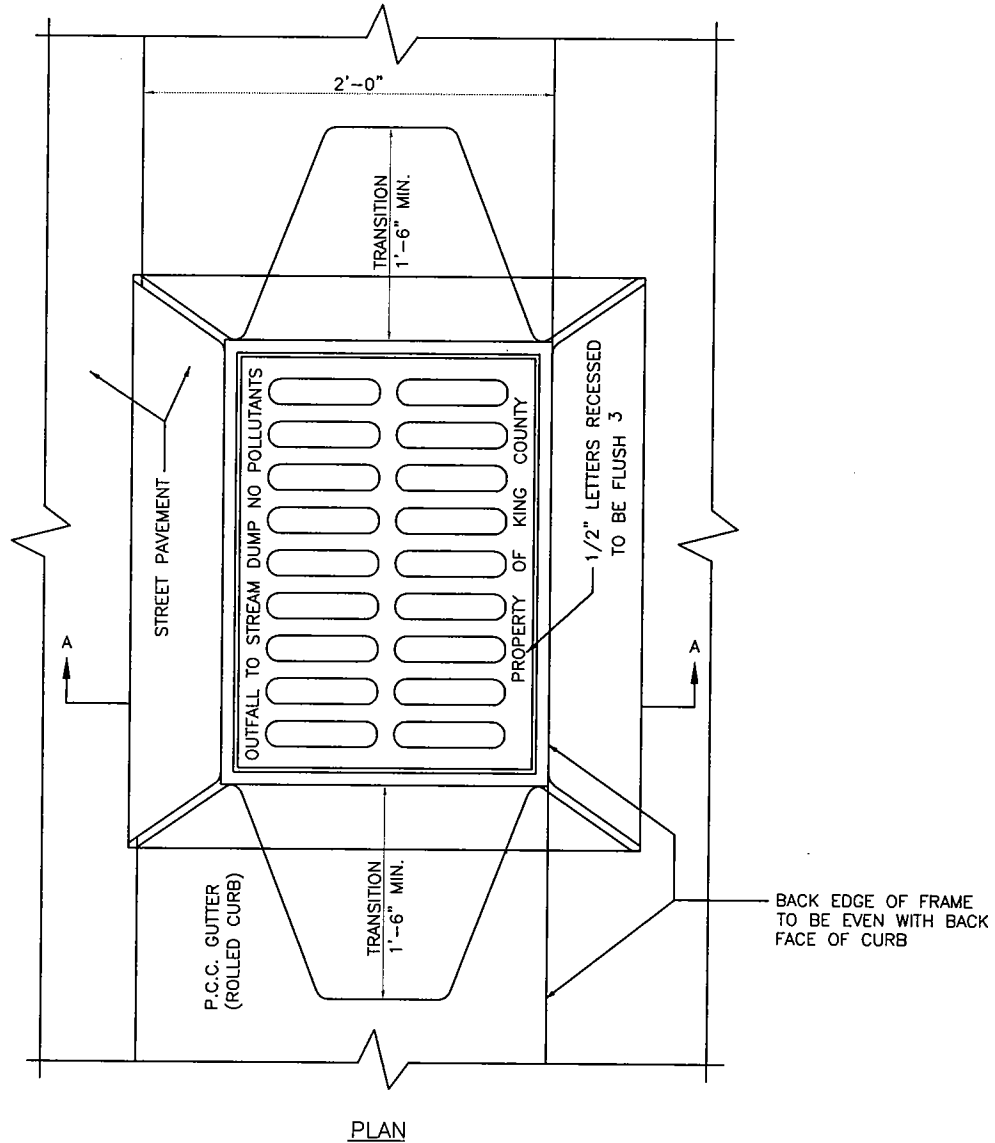
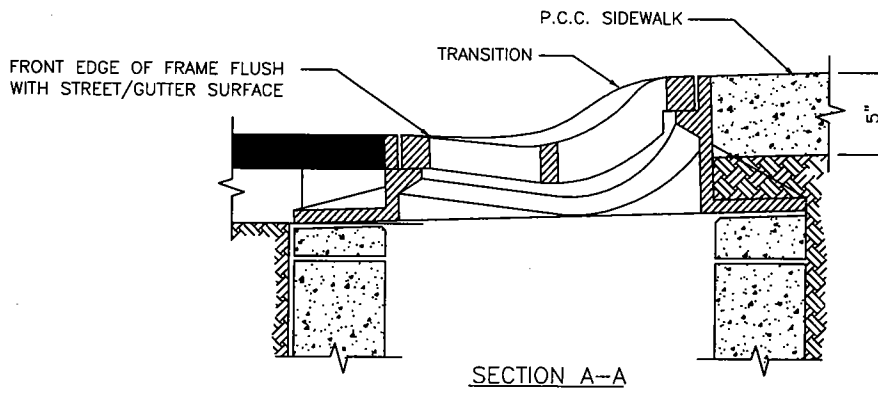

NOTES:

1. SET FRAME TO GRADE AND CONSTRUCT ROAD AND CURB TO BE FLUSH AT FRONT AND BACK OF FRAME.
2. SEE SEC. 7.05.
3. THE WORDS "PROPERTY OF KING COUNTY" SHALL BE OMITTED IF GRATE IS ON A PRIVATE SYSTEM.
4. NOT TO BE USED ON THICKENED EDGE ROADWAYS.

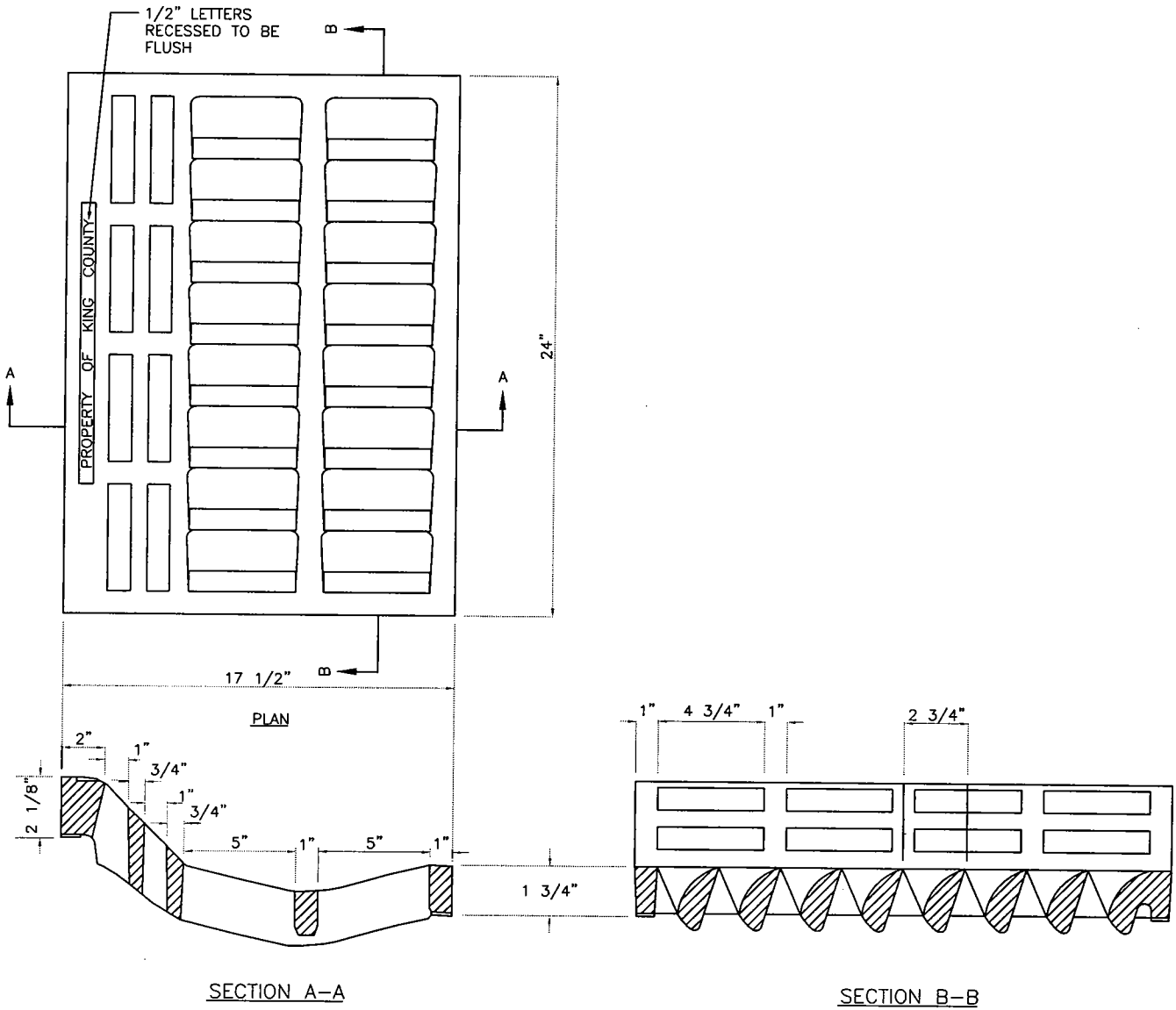

NOTES:

1. MATERIAL IS CAST IRON ASTM A48 CLASS 30.
2. SEE SEC. 7.05.
3. THE WORDS "PROPERTY OF KING COUNTY" SHALL BE OMITTED IF ON A PRIVATE SYSTEM.

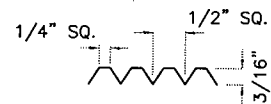
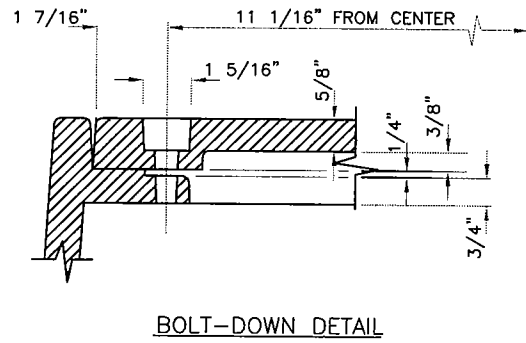
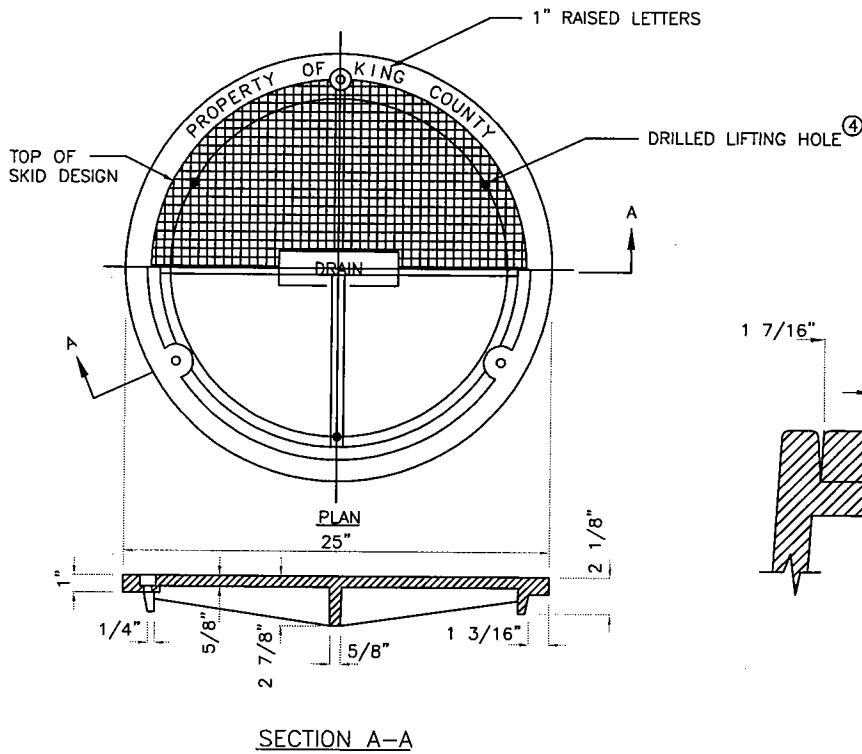

NOTES:

1. USE WITH THREE LOCKING BOLTS 5/8 IN.-11 NC STAINLESS TYPE 304 STEEL SOCKET HEAD (ALLEN HEAD) CAP SCREWS 2 IN. LONG. DRILL HOLES SPACED 120° AT 11 1/16 IN. RADIUS.
2. MATERIAL IS DUCTILE IRON ASTM A536 GRADE 80-55-06
3. SEE SEC. 7.05.
- ④ DRILL THREE 1 IN. HOLES SPACED AT 120° AND 9 1/2 IN. RADIUS.

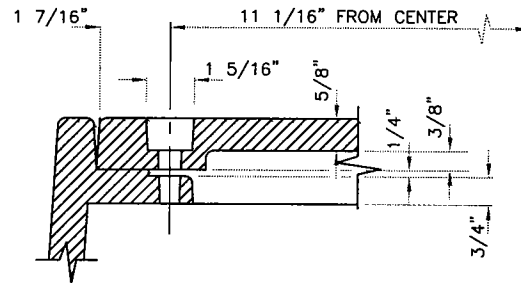
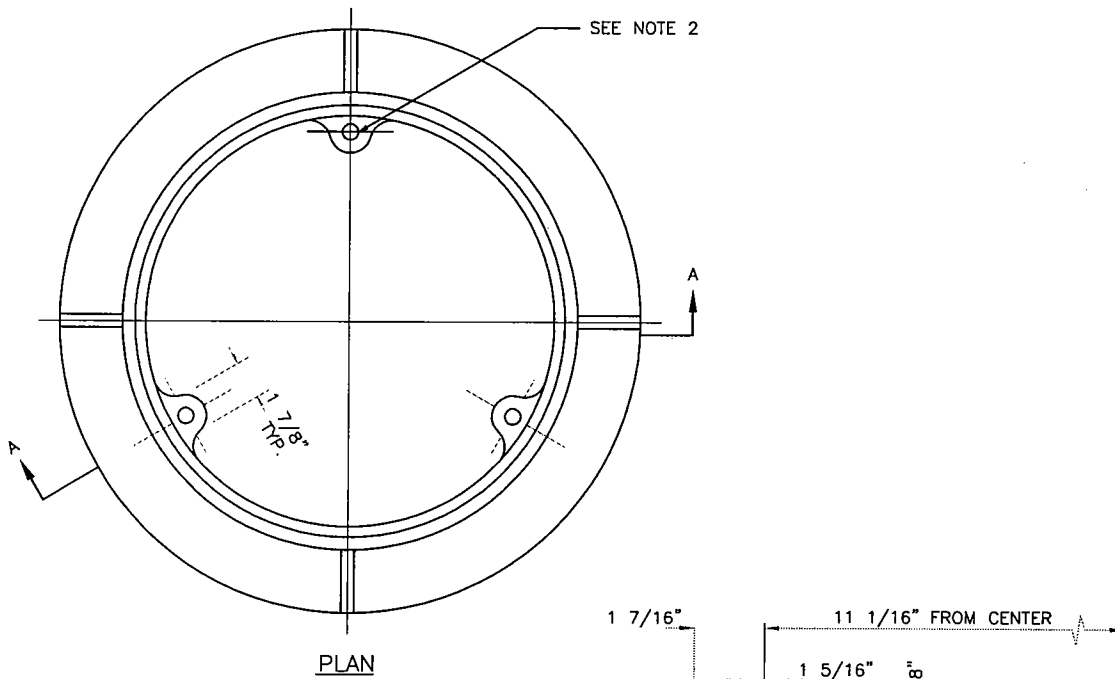

BOLT-DOWN DETAIL

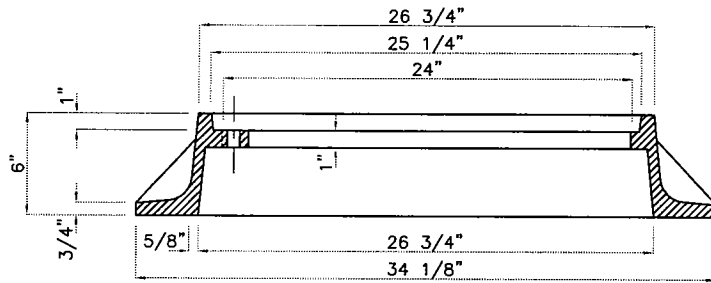

SECTION A-A

NOTES:

1. MATERIAL IS CAST IRON ASTM A48 CLASS 30.
2. DRILL AND TAP THREE 5/8 IN.-11 NC HOLES THROUGH FRAME AT 120° AND 11 1/16 IN. RADIUS.
3. SEE SEC. 7.05.

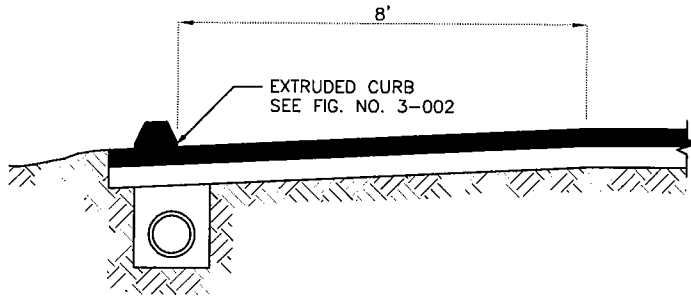

CURBED SHOULDER

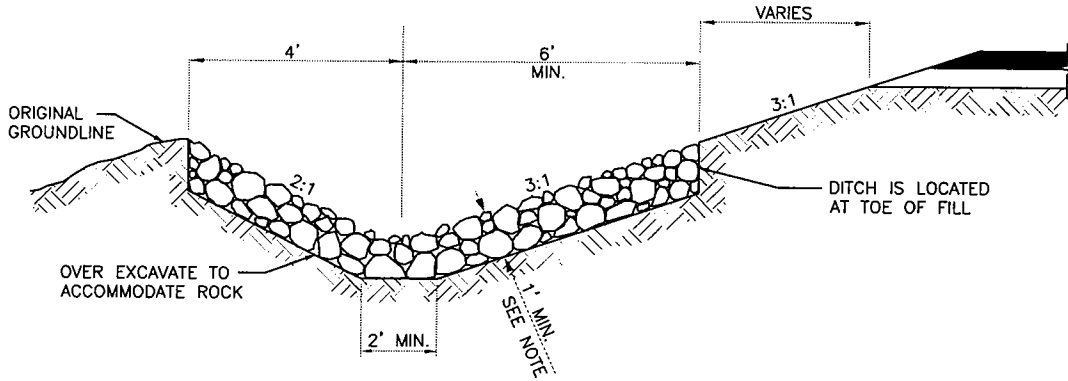

ROCK-LINED SHOULDER DITCH
IN FILL SECTION

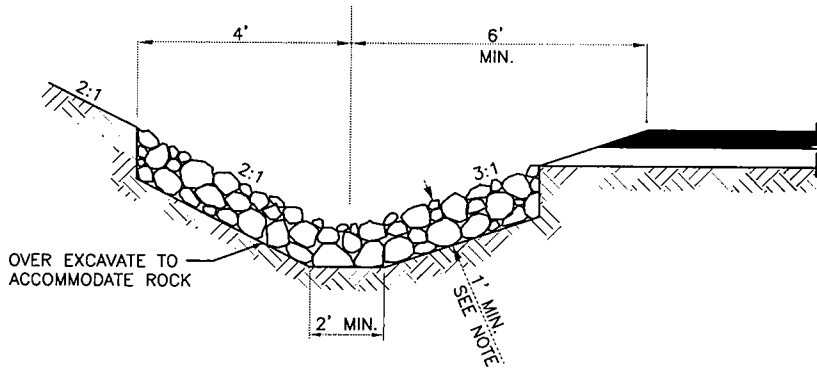

ROCK-LINED SHOULDER DITCH
IN CUT SECTION

NOTES:

1. DEEPER ROCK FILL MAY BE SPECIFIED.
2. SEE SEC. 7.02.

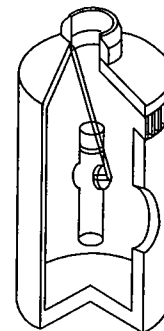
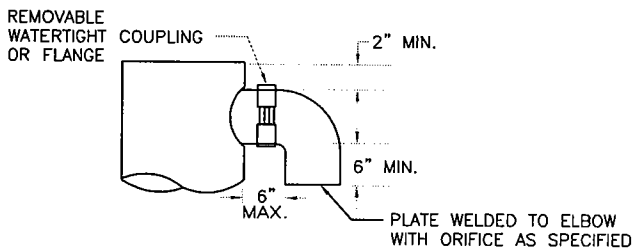
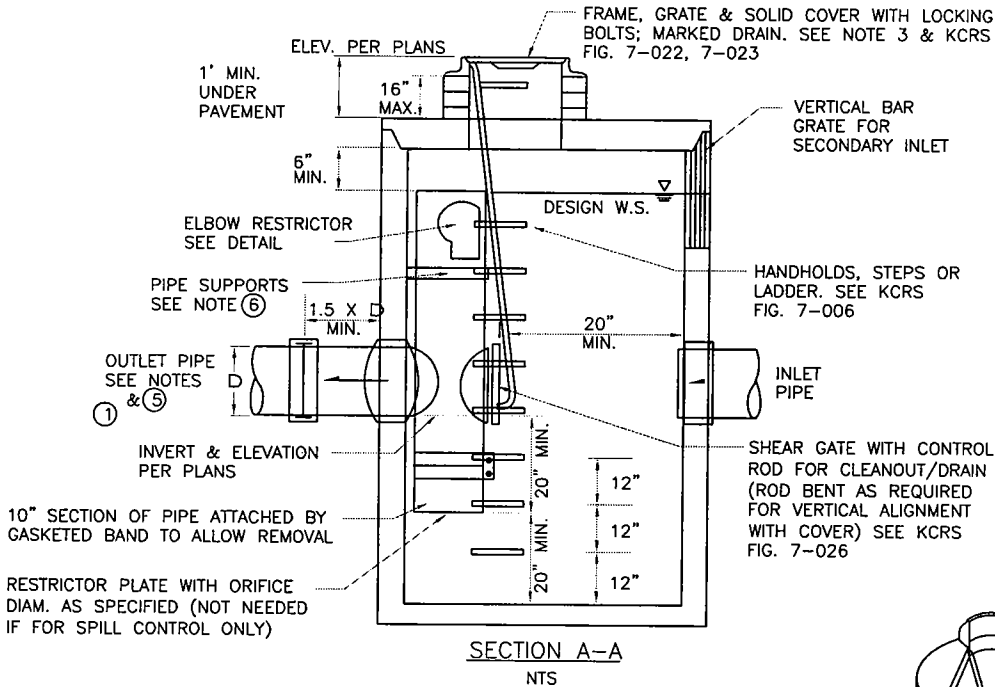
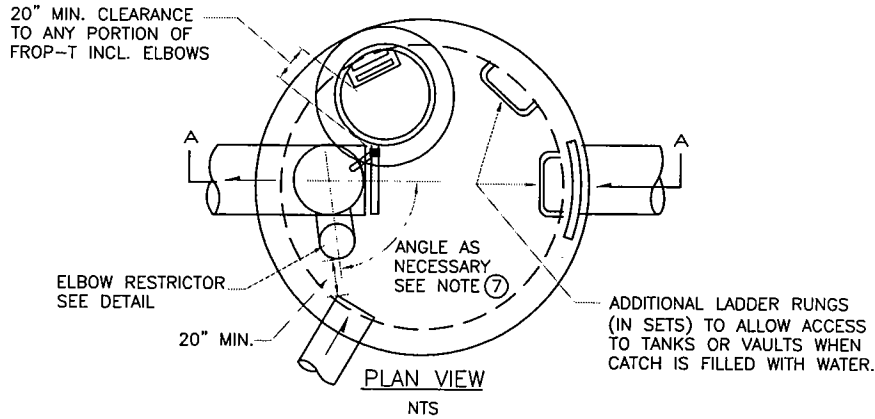

NOTES:

- ① USE A MINIMUM OF A 54 IN. DIAM. TYPE 2 CATCH BASIN.
- ② OUTLET CAPACITY: 100-YEAR DEVELOPED PEAK FLOW.
- ③ METAL PARTS: CORROSION RESISTANT. NON-GALVANIZED PARTS PREFERRED. GALVANIZED PIPE PARTS TO HAVE ASPHALT TREATMENT 1.
- ④ FRAME AND LADDER OR STEPS OFFSET SO:
 - A. CLEANOUT GATE IS VISIBLE FROM TOP;
 - B. CLIMB-DOWN SPACE IS CLEAR OF RISER AND CLEANOUT GATE;
 - C. FRAME IS CLEAR OF CURB.
- ⑤ IF METAL OUTLET PIPE CONNECTS TO CEMENT CONCRETE PIPE, OUTLET PIPE TO HAVE SMOOTH O.D. EQUAL TO CONCRETE PIPE I.D. LESS 1/4 IN.
- ⑥ PROVIDE AT LEAST ONE 3 X 0.090 GAUGE SUPPORT BRACKET ANCHORED TO CONCRETE WALL WITH 5/8 IN. STAINLESS STEEL EXPANSION BOLTS OR EMBEDDED SUPPORTS 2 IN. INTO M/H WALL (VERTICAL SPACING).
- ⑦ LOCATE ELBOW RESTRICTOR(S) AS NECESSARY TO PROVIDE MIN. CLEARANCE AS SHOWN.
- ⑧ LOCATE ADDITIONAL LADDER RUNGS IN STRUCTURES USED AS ACCESS TO TANKS OR VAULTS TO ALLOW ACCESS WHEN CATCH BASIN IS FILLED WITH WATER.

SIX EVENLY SPACED HOLES ON 10 3/8" BOLT CIRCLE FOR BOLTING TO FLANGE CONNECTION.

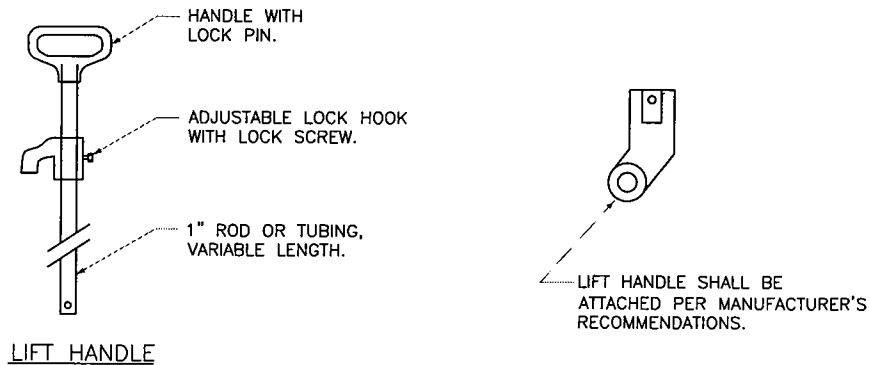
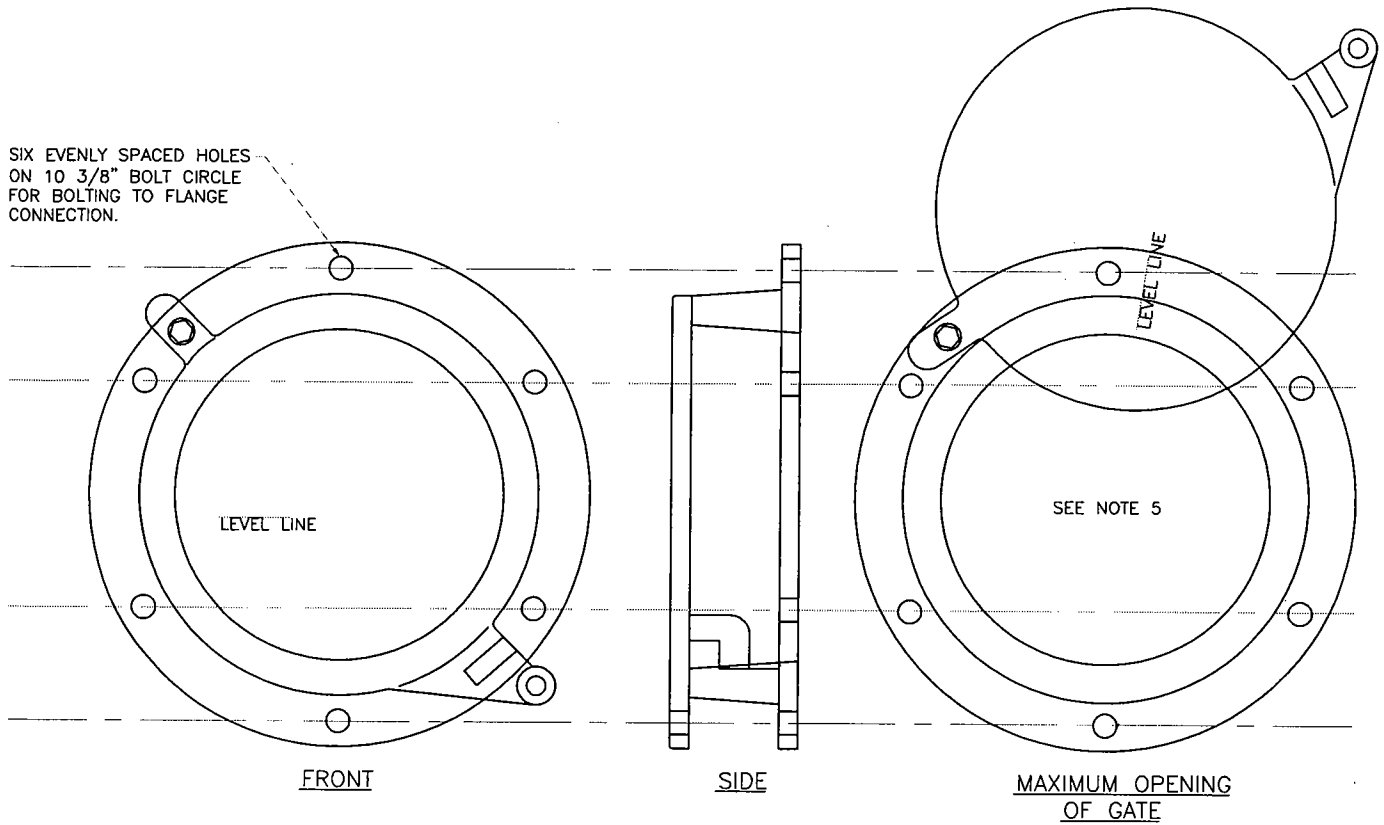

NOTES:

1. SHEAR GATE SHALL BE ALUMINUM ALLOY PER ASTM B-26-ZG-32 α OR CAST IRON ASTM A48 CLASS 30B AS REQUIRED.
2. GATE SHALL BE 8 IN. DIAM. UNLESS OTHERWISE SPECIFIED.
3. GATE SHALL BE JOINED TO TEE SECTION BY BOLTING (THROUGH FLANGE), WELDING, OR OTHER SECURE MEANS.
4. LIFT ROD: AS SPECIFIED BY MFR. WITH HANDLE EXTENDING TO WITHIN ONE FOOT OF COVER AND ADJUSTABLE HOOK LOCK FASTENED TO FRAME OR UPPER HANDHOLD.
5. GATE SHALL NOT OPEN BEYOND THE CLEAR OPENING BY LIMITED HINGE MOVEMENT, STOP TAB, OR SOME OTHER DEVICE.
6. NEOPRENE RUBBER GASKET REQUIRED BETWEEN RISER MOUNTING FLANGE AND GATE FLANGE.
7. MATING SURFACES OF LID AND BODY TO BE MACHINED FOR PROPER FIT.
8. FLANGE MOUNTING BOLTS SHALL BE 3/8 IN. DIAM. STAINLESS STEEL.
9. ALTERNATE CLEANOUT/SHEAR GATES TO THE DESIGN SHOWN ARE ACCEPTABLE, PROVIDED THEY MEET THE MATERIAL SPECIFICATIONS ABOVE AND HAVE A SIX BOLT, 10 3/8 IN. BOLT CIRCLE FOR BOLTING TO THE FLANGE CONNECTION.

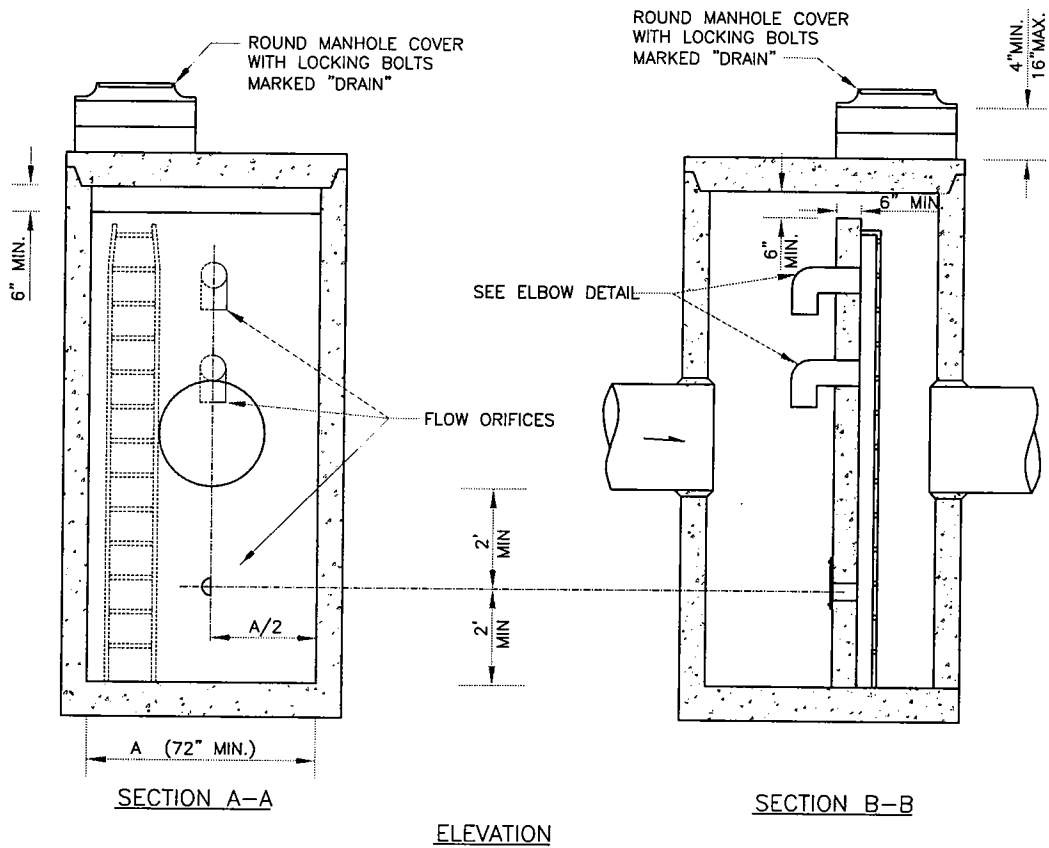

ELEVATION

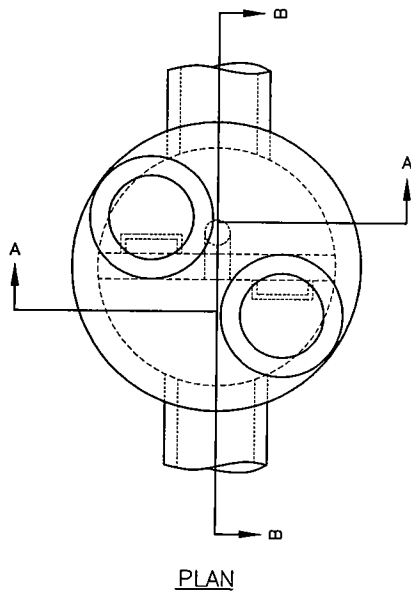

PLAN

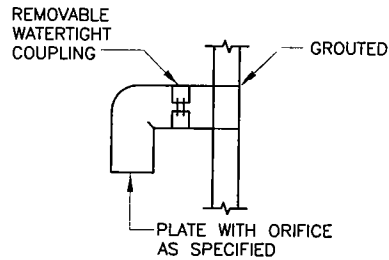

ELBOW DETAIL

NOTES:

1. PIPE SIZE, SLOPES AND ALL ELEVATIONS: PER PLANS.
2. OUTLET CAPACITY: NOT LESS THAN COMBINED INLETS.
3. CATCH BASIN: TYPE 2, TO BE CONSTRUCTED IN ACCORDANCE WITH FIG. 7-005 AND AASHTO M199 UNLESS OTHERWISE SPECIFIED.
4. COVERS: ROUND, SOLID MARKED "DRAIN," WITH LOCKING BOLTS SEE FIG. 7-022 AND 7-023.
5. ORIFICES: SIZED AND LOCATED AS REQUIRED, WITH LOWEST ORIFICE MIN. 2 FT. FROM BASE.
6. BAFFLE WALL SHALL HAVE #4 BAR AT 12 IN. SPACING EACH WAY.
7. PRECAST BAFFLE WALL SHALL BE KEYED AND GROUTED IN PLACE.
8. BOTTOM ORIFICE PLATE TO BE 1/4 IN. MIN. NON-GALVANIZED CORROSIVE RESISTANT MATERIAL AND ATTACHED WITH 1/2 IN. STAINLESS STEEL BOLTS. OMIT ORIFICE PLATE IF ONLY FOR OIL SEPARATION.
9. UPPER FLOW ORIFICE SHALL BE ALUMINUM, ALUMINIZED STEEL OR GALVANIZED STEEL. SEE FIG. 7-025. NON GALVANIZED CORROSIVE RESISTANT MATERIAL SHALL HAVE TREATMENT 1.

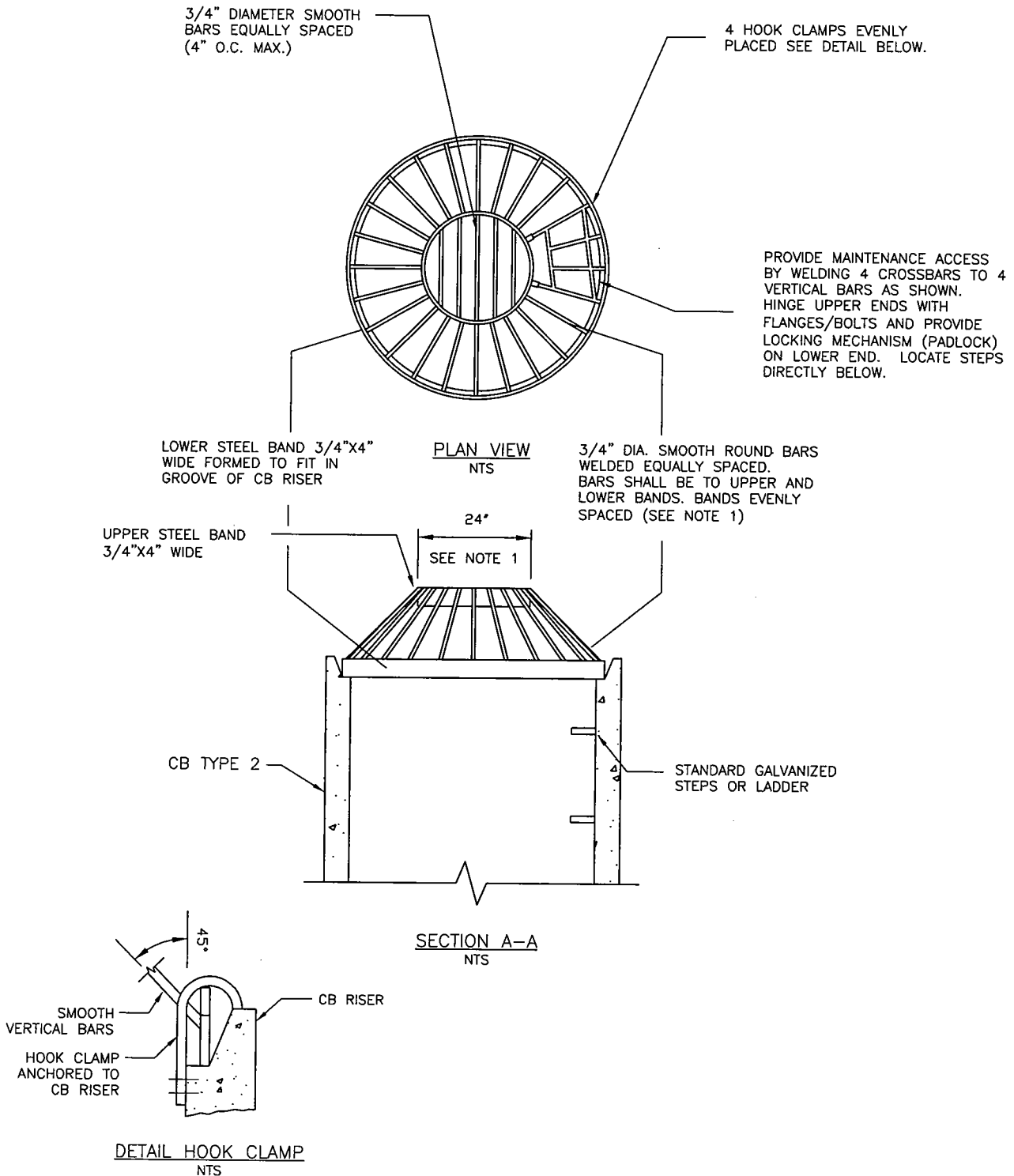

NOTES:

1. DIMENSIONS ARE FOR ILLUSTRATION ON 54 IN. DIAMETER CB. FOR DIFFERENT DIAMETER CB'S, ADJUST TO MAINTAIN 45° ANGLE ON "VERTICAL" BARS AND 4 IN. O.C. MAXIMUM SPACING OF BARS AROUND LOWER STEEL BAND.
2. METAL PARTS MUST BE CORROSION RESISTANT, STEEL BARS MUST BE GALVANIZED.
3. THIS DEBRIS BARRIER IS ALSO RECOMMENDED FOR USE ON THE INLET TO ROADWAY CROSS-CULVERTS WITH HEIGHT POTENTIAL FOR DEBRIS COLLECTION (EXCEPT ON TYPE 2 STREAMS)
4. USE OF THIS STRUCTURE WITHIN THE ROAD RIGHT-OF-WAY SHALL MEET THE MINIMUM CLEAR ZONE REQUIREMENTS.

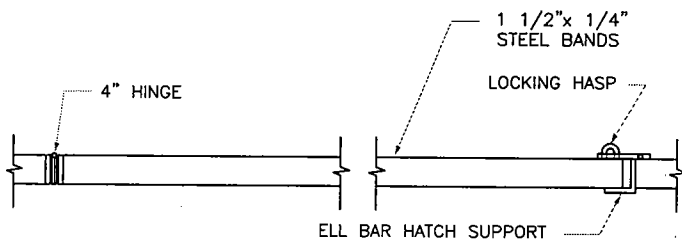
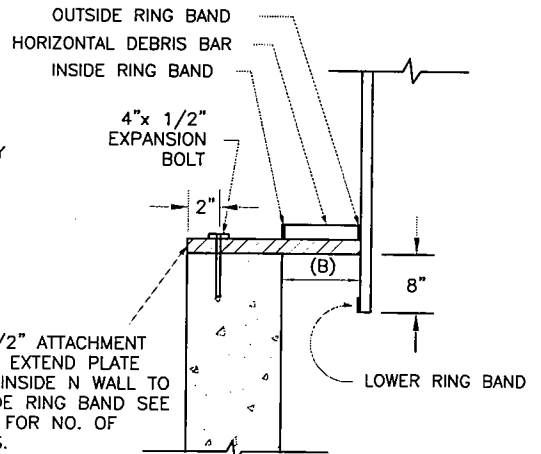
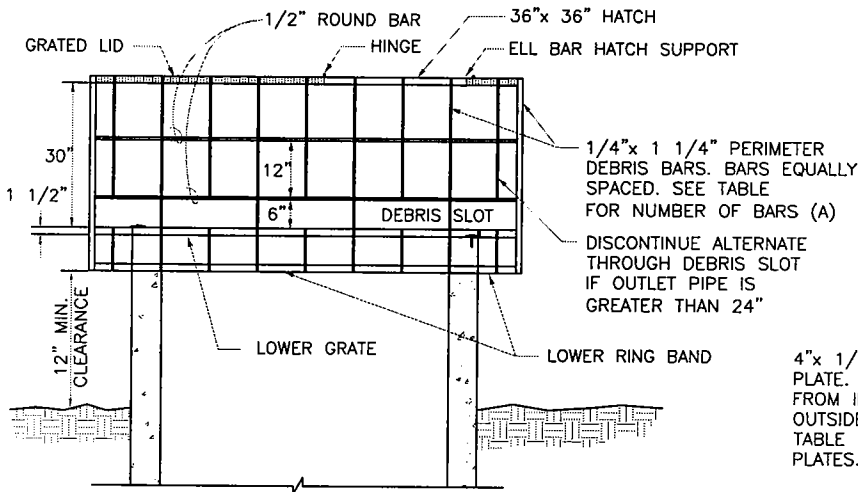
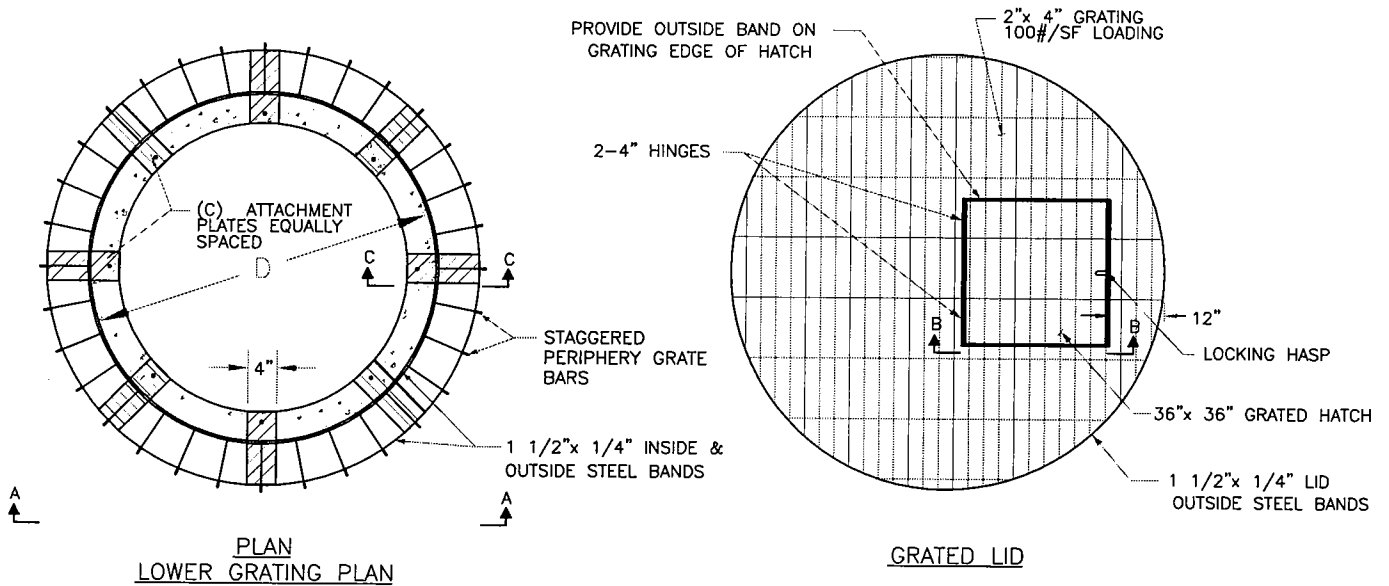

NOTES:

1. ALL PARTS OF THE CAGE SHALL BE GALVANIZED STEEL AND JOINTS WELDED. IN ADDITION WHERE SPECIFIED, DEBRIS CAGE SHALL BE SHOP PAINTED FLAT BLACK. WHERE PAINTING IS SPECIFIED PRE-TREAT GALVANIZED METAL PER MIL-P-15328 THEN FINISH WITH FLAT BLACK ETCHING PRIMER 2 MILS DRY.
2. UNLESS INDICATED OTHERWISE ALL BANDS AND BARS SHALL BE 1 1/2" X 1/4".
3. GRATED LID SHALL BE CONSTRUCTED TO WITHSTAND A 100 PSF LOADING.

TABLE OF VARIABLES

CB DIA. INSIDE	No. OF BARS (A)	(B)	No. OF ATTACHMENT PLATES (C)	(D)
48"	26	8"	4	60"
54"	29	8"	6	67"
60"	32	10"	6	74"
72"	39	12"	8	88"
96"	50	12"	8	116"

CHAPTER 8. UTILITIES & INSTALLATION

8.01 Franchising Policy and Permit Procedure

- A. Utilities to be located within existing and proposed County road right-of-way shall be constructed in accordance with current franchise and/or permit procedure, the County's Regulations for Accommodation of Utilities, and in compliance with these Standards. In their use of the right-of-way, utilities will be given consideration in concert with the traffic-carrying requirements of the road which are, namely, to provide safe, efficient and convenient passage for motor vehicles, pedestrians, and other transportation uses. Aesthetics shall be a consideration. Under grounding of electric utilities will be strongly encouraged, particularly in urban development. Utilities are subject to County Codes and policies relating to drainage, erosion/sedimentation control and sensitive areas as set forth in KCC 9.04 and the Surface Water Design Manual.
- B. All permits for new placement and replacement of existing utility poles and other utility structures above grade shall be accompanied by written certification from the utility's professional engineer or from an agent authorized by the utility to certify that the installations conform to these Standards and that the proposed work is in conformity with sound engineering principles relating to highway safety.
- C. Requests for exceptions to these Standards will be processed in accordance with variance procedure as referenced in Section 1.11.

8.02 Standard Utility Locations Within the Right-of-Way

Utilities within the right-of-way on new roads or on roads where existing topography, utilities or storm drains are not in conflict shall be located as shown in typical sections, figures 2-001 through 2-005, and as indicated below. Where existing utilities or storm drains are in place, new utilities shall conform to these Standards as nearly as practicable and yet be compatible with the existing installations. Above ground utilities located within intersections shall be placed so as to avoid conflict with placement of curb ramps.

- A. Gas and Water Lines:
 - 1. Shoulder-and-Ditch Section:
In shoulder 3 feet from edge of traveled lane.
 - 2. Curb and Gutter Section:
Preferable: 1.5 feet back of curb, or at distance which will clear root masses of street trees if these are present or anticipated.
Otherwise: In the street as close to the curb as practical without encroachment of the storm drainage system. Mains and service connections to all lots shall be completed prior to placing of surface materials.

3. Designated Side of Centerline:
GAS: South and West. WATER: North and East.
 4. Depth: 36 inches minimum cover from finished grade, ditch bottom or natural ground.
- B. Individual water service lines and side sewers shall:
1. Be placed with minimum 36-inch cover from finished grade, ditch bottom or natural ground.
 2. Use road right-of-way only as necessary to make side connections.
 3. For any one connection, not extend more than 60 feet along or through the right-of-way, or the minimum width of the existing right-of-way.
 4. Water meter boxes, when placed or replaced, shall be located on the right-of-way line immediately adjacent to the property being served, unless otherwise approved by the County Road Engineer.
- C. Sanitary Sewers: In the general case, 5 feet south and west of centerline; depth 36-inch minimum cover from finished grade, ditch bottom or natural ground. Side Sewers
1. Side Sewers shall be provided to all adjacent lots or parcels.
 2. Side Sewers shall be placed within ten (10) degrees of perpendicular to road centerline.
- D. In the case of individual sanitary sewer service lines which are force mains the pipe shall:
1. Be minimum two inches I.D., or as required by the utility to maintain internal scouring velocity.
 2. If nonmetallic, contain wire or other acceptable proximity detection features; or be placed in a cast iron or other acceptable metal casing.
 3. Be placed with minimum three-foot cover from finished grade, ditch bottom or natural ground, within 10 degrees of perpendicular to road centerline, and extend to right-of-way line.
 4. Be jacked or bored under road unless otherwise approved by the County Road Engineer.
- E. Sanitary and water lines shall be separated in accordance with good engineering practice such as the Criteria for Sewage Work Design, Washington Department of Ecology, latest edition.
- F. Gravity systems, whether sanitary or storm drainage, shall have precedence over other systems in planning and installation except where a non-gravity system has already been installed under previous approved permit and subject to applicable provisions of such permits or franchises.
- G. Electric utilities, power, telephone, cable TV, fiber optic conduit: Preferable, underground with 36-inch minimum cover, either side of road, at plan location

and depth compatible with other utilities and storm drains. Otherwise, every new placement and every replacement of existing utility poles and other utility structures above grade shall conform to the following:

1. Utility poles or other approved essential roadside obstacles may be placed within the right-of-way and shall be as far back from the traveled way or auxiliary lane as practicable. When allowed they shall be located as follows:
 - a. On shoulder type or mountable curb roads, installation of new or relocated poles or obstacles shall be located behind existing ditches and in accordance with the criteria in Section 5.10 and Drawing No. 5-001. Placement of barrier between the traveled way and the pole or obstacle shall not satisfy this requirement unless the barrier already exists for other purposes and the pole provides a minimum of 3.5-foot separation from the barrier or unless allowed by an approved variance. Variances will be considered only when other reasonable alternatives do not exist.
 - b. On vertical curb-type roads with a speed limit less than 40 mph, poles or obstacles shall be placed clear of sidewalks and at least 8.5-feet from face of curb in commercial/business areas and 5.5-feet from curb face in residential areas. On urban roads with speed limits of 40 miles per hour or greater, hazardous objects shall be placed as close to the right-of-way line as practicable and a minimum of 10 feet from the edge of the traveled way or edge line and in accordance with figure 5-001. The Development Engineer or County Road Engineer must approve placement of utility poles and other essential roadside obstacles structures within planter strips.
 - c. Notwithstanding other provisions regarding pole locations described in these standards, no pole shall be located so that it poses a hazard to the general public. Utilities shall place and replace poles with primary consideration given to public safety. Existing utility poles that do not comply with County standards and are struck, are considered to be a hazard by the County and shall be mitigated by the utility in accordance with these Standards. Additionally, existing utility poles that comply with County standards and are struck at least two times within the same ten-year period shall be mitigated by the responsible utility in accordance with these Standards.
 - d. Every effort shall be made to meet the standards during emergency replacement of existing utility poles and other structures. After a pole has been replaced, all utilities sharing that pole shall have a maximum of 180 days to relocate their facilities to the new pole and remove the old pole.
2. The above constraints on pole and obstacle location will not apply to locations not accessible by moving vehicles, "breakaway" structures whose break-off resistance does not exceed that of a single 4 inches x 4

inches wood post or a 1.5-inch standard (hollow) iron pipe or to "breakaway" fire hydrants installed to manufacturer's specifications.

3. Deviations from these pole and obstacle clearance criteria will only be allowed through an approved variance when justified by suitable engineering study considering traffic safety. For franchised utility permits, the Utility may request a variance from pole and obstacle clearance criteria. Up to three contiguous damaged or weakened poles may be replaced at existing locations under permit in accordance with emergency procedures; however, sequential permits resulting in continuous replacement of a pole line shall not be allowed. A pole or other obstacle, which incurs repeated damage from errant vehicles, shall be relocated outside the clear zone.
 4. Locations of poles shall also be compatible with driveways, intersections, and other road features (i.e., they shall not interfere with sight distances, road signing, traffic signals, culverts, etc.). To the extent possible, utilities shall share facilities so that a minimum number of poles are needed.
 5. Where road uses leave insufficient overhang, anchor, and tree-trimming space for overhead utilities, additional easements and/or right-of-way may be required. The costs associated with additional easements and/or right-of-way for this purpose shall be borne by the applicant, builder, or other party initiating the improvement. The associated cost of relocating the utility shall not be borne by King County.
- H. Notwithstanding other provisions, underground systems shall be located at least 5-feet away from the road centerline and where they will not otherwise disturb existing survey monumentation.

8.03 Underground Installations

All hard surface roadways shall be jacked or bored. Exceptions will be on a case-by-case basis with the expressed permission of the County Road Engineer. The current WSDOT/APWA Standard Specifications, Sections 7-08 and particularly 7-08.3(3) will generally apply unless otherwise stated.

New Roadway Construction, Reconstruction and Widening

1. Cuts on traveled way

When approved, the open cut shall be a neat-line cut made by either saw cutting or jackhammering a continuous line. Trench sides shall be kept as nearly vertical as possible. Compaction and restoration must be done as detailed below and immediately after the trench is backfilled, so as to cause least disruption to traffic. Cement concrete pavement shall be cut one foot outside the edge of the trench on each side. The asphalt or cement pavement shall be cut a minimum of one foot beyond the edges of the trench.

2. Cuts parallel and traverse to road alignment:

- a. The entire trench must meet 95 percent of the maximum density as determined by the compaction control tests described in Section 2-03.3(14)D of the WSDOT/APWA Standard Specifications

Regardless of trench depth, a contractor can use native mineral soil or can import an unclassified mineral soil as backfill, provided the material meets the requirements of Section 9-03.14(3) of the WSDOT/APWA Standard Specifications for Common Borrow. The material shall not contain more than three-percent organic material by weight. The material shall be mechanically compacted to a minimum of 95 percent of maximum density. When the material remaining in the trench bottom is unsuitable, the excavation shall be continued to such additional depth and width as required by Inspector. In any trench where compaction cannot be attained with the native or unclassified backfill, the trench must be backfilled and compacted with "Gravel Borrow" that meets the requirements of WSDOT/APWA Standard Specifications, Section 9-03.14(1). The "Gravel Borrow" shall be mechanically compacted to a minimum of 95 percent of maximum density.

After backfill and compaction an immediate cold mix patch shall be placed and maintained in a manner acceptable to the County Road Engineer. On asphalt pavement, a permanent hot mix patch the same thickness as the existing asphalt or a minimum of 2 inches, whichever is greater, shall be placed and sealed with a paving grade asphalt within 30 calendar days. Cement concrete pavement shall be restored in accordance with Section 5-05.3(22) of the WSDOT/APWA Standard Specifications.

- b. Backfill used for trenches exceeding 15 feet in depth will require a soil analysis prior to plan approval.
- c. Backfill outside the roadway prism shall be excavated material free of wood waste, debris, clods and/or any rocks exceeding six-inches in any dimension and meet compaction requirements.
- d. Restoration of a trench within an asphalt pavement shall include a minimum of 6.5 inches of crushed surfacing material and HMA the same thickness as the existing asphalt pavement or a minimum of 2 inches, whichever is the greater. Pavement shall then be overlaid full width with a minimum of 1.5inch compacted HMA. Prior to the overlay, transverse joints and vertical curb lines shall be planed in accordance with figure 5-021. Exceptions to this overlay requirement will be granted only through variance, subject to approval by the County Road Engineer, after considering the pre-existing condition, damage caused by construction, and rating of the pavement. Concrete pavement shall be restored consistent with Section 6-02 of the WSDOT/APWA Standard Specifications. Any concrete pavement

traffic lane affected by the trenching shall have all affected panels replaced.

B Existing Roadways:

1. Cuts on Traveled Way

All hard surface roadways shall be jacked or bored. Exceptions will be on a case-by-case basis with the expressed permission of the County Road Engineer if it can be shown that jacking or boring are not possible due to conflicts or soil conditions, or unless the utility, including drainage structures, can be installed just prior to reconstruction or overlay of the roadway.

2. Cuts Parallel to Road Alignment:

In cuts parallel to the road alignment, the entire trench shall meet the requirements of Section 8.03A(2) of these Standards. Trench restoration shall satisfy the requirements of Section 8.03A(2)(d) when cuts occur within the traveled way. All cuts outside the traveled way that are located in paved areas shall be restored. The restoration shall include but is not limited to repairing all failures and cracking of the paved surface, repairing failures caused by the construction activity, rebuilding the cross slope to uniformity, and overlaying the area where the pavement was removed.

3. Cuts Traverse to Road Alignment

- a. Without exception, the entire trench shall be backfilled with 1 ¼-inch minus crushed surfacing base course meeting the requirements of Section 9-03.9(3) of the WSDOT/APWA Standard Specifications. Backfill shall be placed and compacted mechanically in 6-inch lifts to 95 percent of the maximum density as determined by the compaction control tests described in Section 2-03.3(14)D of the WSDOT/APWA Standard Specifications. If the capability can be demonstrated, based on compaction equipment or quality of backfill to achieve 95 percent density in thicker lifts, the depth of backfill lifts may be increased up to 1 foot. If the Inspector approves use of CDF, it shall meet the requirements of Section 8.03(C) of these Standards.
- b. After backfill and compaction, an immediate cold mix patch shall be placed and maintained in a manner acceptable to the County Road Engineer. On asphalt pavement, a permanent hot mix patch the same thickness as the existing asphalt or a minimum of 2 inches, whichever is the greater, shall be placed and sealed with a paving grade asphalt within 30 calendar days. Cement concrete pavement shall be restored with an eight-sack mix, using either Type II or Type III cement, within 30 calendar days.

C. Controlled Density Backfill:

As an alternative to mechanical compaction, trench backfill above the bedding and below the base course or ATB may be accomplished by use of controlled density backfill (CDF) in a design mixture according to Section 2-09.3(1) E of WSDOT/APWA Standard Specifications. The contractor shall provide a mix design in writing and the CDF shall not be placed until the Engineer has reviewed the mix design. CDF shall meet the requirements of Section 6-02.3(5)C of the WSDOT/APWA Standard Specifications and shall be accepted based on a Certificate of Compliance. The producer shall provide a Certificate of Compliance for each truckload of control density fill. The Certificate of Compliance shall verify that the delivered material is in compliance with the mix design. Testing of CDF shall be in accordance with ASTM D4832.

Note: On crossings required to be opened to traffic, and prior to final trench restoration, steel plates shall be installed by the contractor as directed by the County Road Engineer or Development Engineer.

8.04 Notification and Inspection

Consistent with Section 9.02 of these Standards, any applicant, utility, or others intending to trench existing or proposed traveled County roads shall notify the County as set forth in Section 9.02 of these Standards for all work associated with a land use permit, and not less than one working day prior to beginning utility construction. This notification shall include:

1. Location of the work
2. Method of compaction to be used
3. Day and hour when compaction is to be done
4. Day and hour when testing is to be done.

Telephone numbers are as follows:

Land Use Inspection 206-296-6642

Utility Inspection 206-296-8122

As set forth in Section 9.03 of these Standards, failure to notify may necessitate testing or retesting by King County at the expense of the Applicant or Utility. Furthermore, the work may be suspended pending satisfactory test results.

8.05 Final Adjustment (To Finish Grade)

- A. All utility covers, including drainage, which are located on proposed asphalt roadways, shall be temporarily placed at subgrade elevation prior to placing crushed surfacing material.
- B. Final adjustment of all covers and access entries shall be made following final paving by:

1. Saw-cutting or neat-line jack hammering of the pavement around lids and covers. Opening should not be larger than 12 inches beyond the radius of the cover.
2. Removing base material, surfacing course, and frame; adding raising bricks; replacing frame and cover no higher than finished grade of pavement and no lower than one-half inch below the pavement.
3. Filling and mechanically compacting around the structure and frame with crushed surfacing material or ATB, or pouring in 5-inch minimum thickness of cement concrete Class 3000 to within 2 inches of the top.
4. Filling the remaining 2 inches with HMA compacted and sealed to provide a dense, uniform surface.
5. Final adjustment of all covers and access entries shall be completed within 30 days of final paving.

8.06 Final Cleanup, Restoration of Surface Drainage and Erosion/Sediment Control

In addition to restoration of the road as described above, the responsible applicant, utility, contractor, etc., shall care for adjacent areas in compliance with Sections 1-04.11 "Final Cleanup" and 8-01 "Roadside Seeding" in the WSDOT/APWA Standard Specifications. In particular:

- A. Streets and roads shall be cleaned and swept both during and after the installation work.
- B. Disturbed soils shall be final graded, seeded and mulched after installation of utility. In limited areas seeding and mulching by hand, using approved methods, will be acceptable.
- C. Ditch lines with erodible soil and subject to rapid flows may require seeding, matting, netting, or rock lining to control erosion.
- D. Any silting of downstream drainage facilities, whether ditches or pipe and catch basins, which results from the construction activity shall be cleaned out and the work site restored to a stable condition as part of site cleanup.
- E. Remove all temporary erosion and sediment control materials and fencing and dispose of properly.

CHAPTER 9. CONSTRUCTION CONTROL AND INSPECTION

9.01 Basis for Control of the Work

- A. Work performed in the construction or improvement of public or private roads shall be done in accordance with these Standards and approved plans and any other specifications (Section 1.07) or guidelines. It is emphasized that no work may be started until such plans are approved. Any revision to such plans shall be approved, by the County Road Engineer or Development Engineer before being implemented.
- B. The County Road Engineer is authorized to enforce the Standards as well as other referenced or pertinent specifications or guidelines. He/she will appoint project engineers, assistants, and inspectors as necessary to inspect the work and they will exercise such authority as the County Road Engineer may delegate.
- C. Provisions of Section 1-05 of the WSDOT/APWA Standard Specifications shall apply, with the term "Engineer" therein construed to be the County Road Engineer as defined in Section 1.13.

9.02 Inspection

Generally, on all privately developed infrastructure road and drainage facility construction proposed or in progress by a private developer, control and inspection will be done by the Land Use Inspection Section, (LUIS), on behalf of the County Road Engineer. The custodial agency, (i.e., Road Services Division and Water and Land Resources Division) performs the maintenance/defect inspections. The County Road Engineer must approve any variances from the Standards during construction.

The applicant is ultimately responsible for quality control of construction and the assurance of meeting the standards. LUIS and the custodial agency inspectors monitor these activities with enforcement authority when requirements are not met. All work conducted on electrical and communications systems shall be inspected by the King County Department of Transportation Electrical Inspector. The LUIS Inspector coordinates the inspections.

All materials provided by the contractor shall be subject to inspection and approval by the Inspector at any time during the progress of work until final acceptance. The contractor's construction schedule shall include sufficient time for materials testing and any required verification by the Inspector.

The Inspector has the authority to reject defective material and suspend work that is being done improperly. The Inspector may advise the applicant or contractor of any faulty work or materials; however, failure of the Inspector to advise the applicant or contractor does not constitute acceptance or approval. At the

Inspector's order, the applicant/contractor shall immediately remedy, remove, replace, or dispose of unauthorized or defective work or materials and bear all the costs of doing so.

All roadway and drainage infrastructures must be inspected. Subgrade inspection will not commence until density tests confirm that the compaction is in accordance with the specifications. Prior to any critical task being started the applicant/developer must schedule in advance with LUIS (206) 296-6642: At a minimum the following critical tasks require advance notification:

- A. Preconstruction Conference: Three working days prior notice. Conference must precede the beginning of construction and include the applicant, contractor, design engineer, utilities, and other applicable participants. Plan approvals and permits must be in hand prior to the conference.
- B. Clearing and Temporary Erosion/Sedimentation Control: One working day notice prior to initial site work involving drainage and installation of temporary erosion/sediment control. Such work to be in accordance with Section 7.06 and the approved plans.
- C. Utility and Storm-Drainage Installation: One working day notice prior to trenching and placing of storm sewers and underground utilities such as sanitary, water, gas, power, telephone, and TV lines. See Section 8.03 for additional information.
- D. Utility and Storm Drainage Backfill and Compaction: One working day notice before backfill and compaction of storm sewers and underground utilities.
- E. Subgrade Completion: One working day notice at stage that underground utilities and roadway grading are complete; to include placement of gravel base if required. Inspection to include compaction tests and certifications described in Sections 8.03 and 9.04 of these Standards.
- F. Curb and Sidewalk Forming: One working day notice to verify proper forming and preparation prior to pouring concrete.
- G. Curb and Sidewalk Placement: One working day notice to check placement of concrete.
- H. Sidewalk Forming: One working day notice to verify forms and crushed surfacing base preparation.
- I. Crushed Surfacing Placement: One working day notice to check placement and compaction of crushed surfacing base course and top course.
- J. Paving: Three working days notice in advance of paving with asphalt or Portland cement concrete.
- K. Structural: Three working days notice prior to each critical stage such as placement of foundation piling or footings, placement and assembly of major components, and completion of structure and approaches. Structural tests and certification requirements will be as directed by the County Road Engineer.

- L. Punchlist Inspection: 15 working days prior to overall check of road or drainage project site, to include completion of paving and associated appurtenances and improvements, cleaning of drainage system, and all necessary clean-up. Prior to approval of construction work, acceptance and release of construction performance financial guarantees, the applicant/contractor shall pay any required fees, submit any required maintenance and defect financial guarantees, provide a certificate of monumentation and submit required archival quality plans (see Section 1.10), final corrected plans (as-built drawings) reflecting all minor and design plan changes of the road and drainage systems. The Development Engineer shall specify the number of blue-line sets as warranted by the type of improvement. Mylars and blue-line drawings shall not have shading or adhesive addition in any areas except as allowed in Section 1.10 of these Standards.
- M. Final Maintenance Inspection: The final maintenance inspection is performed by the Department of Transportation Road Services Division and/or the Department of Natural Resources and Parks Water Land and Resources Division 45 days prior to the end of the maintenance period. Prior to release of the maintenance financial guarantee, there shall be successful completion of the maintenance period as described in Section 1.12, replacement/repair of any failed facilities, and the payment of any outstanding fees.

9.03 Penalties for Failure to Notify and Obtain Approval

Notification by the applicant or the applicant's contractor, at the necessary time frames noted above, is essential for the County to verify, through inspection, that the work meets the standards. Failure to notify and obtain approval will result in the County requiring sampling and testing with certification either by an approved private laboratory or the King County Materials Laboratory. Costs of such testing and certification shall be borne by the applicant. If the test results conclude that the unauthorized work doesn't meet the Standards, the applicant will be required to remove the unauthorized material and replace it with materials that meet the Standards at his/her own expense. At the time that such action is directed by the County Road Engineer, further work on the development may be limited or prohibited until all directed tests have been completed, approved, and all corrections identified by the County have been made to the satisfaction of the County Road Engineer. If necessary, the County may take further action as set forth in King County Code Title 23, Enforcement.

9.04 Control of Materials

- A. Source of Supply and Quality of Materials: The contractor shall notify the County Road Engineer or Development Engineer of proposed sources of supply for all materials to be furnished. The County Road Engineer or Development Engineer shall approve the source of supply of each of the materials before the delivery is started. Representative preliminary samples or test data of the character and quality prescribed may be required to be submitted by the contractor or producer for examination by the County Road Engineer or Development Engineer.

Only materials conforming to the requirements of the WSDOT/APWA Standard Specifications shall be used in the work, unless otherwise approved by the County Road Engineer. Any of the materials proposed to be used may be inspected or tested at any time during their preparation and use. If after testing it is found that sources of supply that were previously approved do not furnish a uniform product, or if the product from any approved source proved unacceptable at any time, the contractor shall furnish approved materials from other approved sources.

- B. Samples and Tests: At the direction of the Development Engineer, the applicant shall direct a certified testing laboratory to conduct necessary field and/or lab tests of materials or methods. All testing shall be in accordance with ASTM and/or AASHTO standards. The applicant/developer shall furnish samples of all materials as requested by the Development Engineer. Materials shall not be used until approved.

The testing laboratory should be present during all field tests. Regardless, the Development Engineer shall be furnished certified copies of the complete test reports directly from the testing laboratory.

9.05 Embankment Construction Control in Developments

The provisions of Section 2-03 of the WSDOT/APWA Standard Specifications apply in all respects to development construction unless otherwise instructed by the County Road Engineer. The following elements are mentioned for clarification and emphasis:

- A. Embankment and Cut Section Compaction: Each layer of the entire embankment shall be compacted to 95 percent of the maximum density as determined by the compaction control tests described in Section 2-03.3(14)D of the WSDOT/APWA Standard Specifications – Method C. In the top two-feet, horizontal layers shall not exceed four-inches in depth before compaction. No layer below the top two-feet shall exceed eight-inches in depth before compaction. The Contractor shall use compacting equipment approved by the Engineer. Any embankment inaccessible to large compacting equipment shall be compacted with small mechanical or vibratory compactors. Control Density Fill shall be used in areas that are difficult to reach with any equipment. The moisture content of the material shall not vary more than 3 percent above or below optimum determined by the tests described in Section 2-03.3(14)D.
- B. Testing for Density
1. Prior to placing any surfacing material on the roadway, it will be the responsibility of the applicant/contractor to provide density test reports reviewed and approved by a professional engineer and accepted by the Inspector. Optimum moisture content and maximum density shall be determined by methods cited in Section 2-03.3(14) D of WSDOT/APWA Standard Specifications or by other test procedures approved by the

County Road Engineer. Any material proposed to be used may be inspected or tested at any time during their preparation and use. If after testing it is found that sources of supply that have been approved do not furnish a uniform product, or if the product from any source proved unacceptable at any time, the contractor shall furnish approved materials from other approved sources. Any approved material that becomes unfit shall not be used. In fill sections, a minimum of one test shall be taken for every 1,000 cubic yards or fraction thereof and on each lift of embankment. In cut sections, the interval shall be every 100 feet of roadway. For work to be accepted, tests must show consistent uniform density as required by tests referenced above.

2. Compaction reports are required for all projects. The reports shall include a sketch showing the locations the tests were taken. Compaction testing shall be accomplished as backfill or embankment construction progresses. At a minimum, compaction tests are required at the following locations. Additional tests and/or shorter intervals may be required by the inspector.
 - a. Trench lines: At one hundred fifty (150) foot intervals (or between structures if less than 150 feet) and for every two (2) foot depth of material placed or as required by the County Road Engineer.
 - b. Road subgrade: At fifty (50) foot intervals for every two (2) feet of material placed.
 - c. All curb and gutter locations: At one hundred fifty (150) foot intervals, each side.
 - d. Crushed Surfacing: At one hundred (100) foot intervals.
 - e. All sidewalk locations: At one hundred fifty (150) foot intervals, each side.
 - f. Compaction around all drainage structures, except when controlled density fill is used.

In cases where tests or frequency of testing do not meet the minimum standard, corrective action shall be taken as directed by the applicant's engineer and approved by the inspector. Retests shall show passing densities prior to placing the next lift of subgrade fill.

3. For trenching in existing roads, see Section 8.03.
4. Each truckload of HMA shall be covered with a suitable tarpaulin while in transit to prevent unnecessary heat loss. When discharged the temperature of the HMA shall not exceed the maximum temperature recommended by the asphalt binder manufacturer. Documentation shall be submitted prior to placement. A maximum water content of 2 percent in the mix, at discharge, will be allowed providing the water causes no problems with handling, stripping, or flushing. If the water in the HMA causes any of these problems, the moisture content shall be reduced as directed by the inspector.

C. Unsuitable Foundation Excavation

The contractor shall excavate unstable natural ground before building any embankment over it. This unstable material may include peat, muck, swampland, buried logs and stumps, or other material not fit for an embankment base. If unsuitable material is encountered, the applicant/contractor shall immediately contact the Inspector. No embankment work shall progress until the Inspector authorizes. Corrective actions may include, but are not limited to, over excavation, dewatering and/or development and approval of a special design section. The contractor shall excavate such material to the boundaries set by the Inspector.

9.06 Subgrade

In preparing the roadbed for surfacing or surfaced roadbed for paving, the requirements outlined in Sections 2-06.3(1) and 2-06.3(2) of the WSDOT/APWA Specifications shall be met. After the subgrade preparation has been completed, it shall be thoroughly checked by the applicant/contractor using a level, string line, crown board, or other means to determine that the subgrade conforms to the approved roadway section and the Standards prior to placing any surfacing material.

9.07 Traffic Control in Development Construction

- A. Interim Traffic Control: The applicant/contractor shall be responsible for interim traffic control during construction on or along traveled County roads. When road or drainage work is to be performed on County roads that are open to traffic, the applicant/contractor will be required to submit a traffic control plan for approval by the Development Engineer prior to beginning the work. Traffic control shall follow the guidelines of Section 1-07.23 of the WSDOT/APWA Standard Specifications. All barricades, signs and flagging shall conform to the requirements of the MUTCD Manual. For more specific requirements for barricades, see Section 5.07 and figure No. 5-002. Signs must be legible and visible and should be removed at the end of each workday if not applicable after construction hours.
- B. Temporary Road Closures and Detours: When temporary road closures cannot be avoided the applicant/contractor shall post "This Road Will Be Closed" signs a minimum of 10 days prior to the closing. The types and locations of the signs shall be shown on a detour plan. A proposal for a road closure and a detour plan must be prepared and submitted to the Department of Transportation, Traffic Engineering Section at least 20 working days in advance, (40 calendar days if arterial) and approved prior to closing any County road. In addition, the applicant/contractor must notify, in writing, local fire, school, or law enforcement authorities, Metro transit, and any other affected persons as directed by the County Road Engineer at least 10 days prior to closing.

- C. **Permits and Haul Route Agreements:** A haul route agreement is required for new and expanded hauling operations within the right-of-way that are anticipated to impact traffic capacity, cause damage or accelerated deterioration to county roads, and to minimize impacts to surrounding residences and businesses. These activities involve, but are not limited to, development construction, logging, pit and quarry operations, major utility construction and similar operations. These agreements may be required through the SEPA process or by the County Road Engineer or Development Engineer. The absence of an agreement does not absolve the user from restoring the right-of-way.

Generally, a right-of-way use, special use, or conditional use permit will be required in conjunction with a haul road agreement. The agreement must be signed by the permittee prior to issuance of the permit to protect the integrity of the roadway surface and other roadway features within the right-of-way. Additionally, existing operations may require a haul route agreement through a conditional use, special use, or right-of-way use permit.

When required, a haul route agreement plan must be prepared by the permittee and submitted to the County Road Engineer for review and approval prior to beginning hauling.

At a minimum, the agreement shall include the haul route, type and number of additional vehicles, hauling period, hours of operation, signage and flagging, daily maintenance, and periodic and final right-of-way and roadway restoration. The County Road Engineer must approve the route. Failure to use the approved designated haul route may result in prohibition or limitation of further work on the development/property until such time as the requirements of the haul route are fulfilled.

The County Road Engineer and permittee shall make joint pre-activity and post-activity inspections of the proposed haul route. Conditions of the road prior to the anticipated activity will be analyzed, documented and agreed upon by the parties prior to signing the agreement and issuance of the permit. The County Road Engineer may require a restoration financial guarantee prior to signing the agreement. When hauling has been completed or a predetermined time interval has been reached, conditions are again documented. If damage occurred as a result of the hauling, prior to release of the financial guarantee the applicant is required to make necessary repairs or compensate the county for the actual costs required to address the damage.

9.08 County Forces and County Contract Road Inspection

Road construction performed by County forces or by contract for the County will be inspected under the supervision of the County Road Engineer.

9.09 Call Before You Dig

Builders are responsible for timely notification of utilities in advance of any construction in right-of-way or utility easements. The utility One-Call Center phone number (1-800-424-5555) should be prominently displayed on the work site.

9.10 Utility Certification

All permits for new placement and replacement of existing utilities and utility structures shall be accompanied by written certification from the utility's professional engineer or from an agent authorized by the utility to certify that the installations conform to these Standards, and that the proposed work is in conformity with sound engineering principles relating to highway safety.